

DATASHEET CATALOG 2022

HYDRONIC BALANCING | AREA HEATING SYSTEMS | SYSTEM TECHNOLOGY |
VALVES AND ACCESSORIES | PUMP TECHNOLOGY

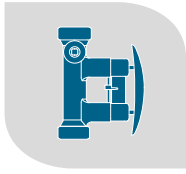

OVERVIEW OF THE AREAS OF EXPERTISE



HYDRONIC BALANCING

Energy in buildings must be distributed in such a way that all building sections, rooms and consumers are supplied according to their needs. A well-balanced system avoids excess and deficient supply of consumer circuits and prevents irritating flow noises in the pipes and valves. The gain in comfort due to pleasant room temperatures and significantly increased energy efficiency are the perceptible and measurable results of hydronically balanced flow systems. Hydronic balancing – the core area of expertise of Taconova – is part of the modern standard and is indispensable in the building service solutions of today.

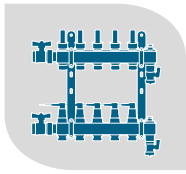

AREA HEATING SYSTEMS

Targeted heating of individual rooms increases the comfort level, reduces energy consumption and enables economic operation of the heating system. Optimum energy distribution is required in this regard: for main distribution in basements or pump rooms, the main flows are distributed to the various parts of the building as part of the hydronic balancing. To ensure the preferred room and heating circuit temperatures, fine distribution is additionally required on each floor, in the form of intelligent and reliable area heating distributors. Taconova's comprehensive range is characterised by products that are optimally matched to each other and can be combined in a variety of ways.

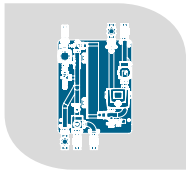

SYSTEM TECHNOLOGY

The demand for universal solutions in building services is greater than ever. Taconova's connection-ready heating circuit pump assemblies, solar loading, domestic hot water and storage loading stations and heat interface units are smart, state of the art systems. Taconova quality products are assembled from carefully selected, tried-and-tested products to create perfectly functioning standard units. The ready-to-use complete solutions simplify and accelerate planning and assembly stages. In everyday use they guarantee reliable operation, reduce maintenance to a minimum and optimize energy costs.

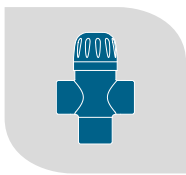

VALVES AND ACCESSORIES

A smoothly running heating or cooling system requires a large number of compact supporters. Valves and accessories from Taconova automatically vent heating systems since only continuously vented heating systems work with the greatest efficiency. Thermal mixer valves reduce the high domestic hot water temperatures to a constant, non-scalding temperature at the outlet. Multifunctional valves and accessories for monitoring the pressure in heating systems provide additional safety. Sophisticated sensors and measuring equipment – for example, for individual heat metering – complete the comprehensive range of Taconova fittings



PUMP TECHNOLOGY

Heat can only be transported within buildings with the aid of pump technology. As devices that carry, transport and transfer heating water to heated rooms, pumps play an important role in ensuring a pleasant building climate. In conjunction with hydronic balancing, the most suitable pump can be selected and adjusted, which reduces operating costs and increases energy efficiency.

CONTENTS

OVERVIEW OF PRODUCTS AND APPLICATION AREAS	4	VALVES AND ACCESSORIES	176
HYDRONIC BALANCING	6	Mixing valves	178
Balancing valves	8	▪ NovaMix Value	183
▪ TacoSetter Bypass 100	13	▪ NovaMix Standard	186
▪ TacoSetter Bypass Solar 130	17	▪ NovaMix High Capacity	189
▪ TacoSetter Bypass Solar 185	21	▪ NovaMix Compact 70	192
▪ TacoSetter Bypass Flange	25	▪ NovaMix Compact 50	194
▪ TacoSetter Inline 100	27	Zone valves	196
▪ TacoSetter Inline 130	31	▪ NovaZone Ball	198
▪ TacoSetter Rondo	35	▪ NovaZone Valve	203
▪ TacoSetter Hyline	37	Multifunctional valves and accessories	206
▪ TacoSetter Tronic	40	▪ TriBloc	208
▪ Glycol correction curves	42	Air, dirt and magnetite separator	210
Flow meter	48	▪ TacoVent Vent	213
▪ TacoControl FlowMeter	50	▪ TacoVent HyVent	215
		▪ TacoVent AirScoop D	217
		▪ MegaFill	220
AREA HEATING SYSTEMS	52	PUMP TECHNOLOGY	224
Underfloor heating systems	54	Heating circuit pumps	228
▪ TacoSys Pro	56	▪ TacoFlow2 (C A) (ES2)	228
▪ TacoSys High End Connect	60	▪ TacoFlow2 ADAPT (ES2 C A)	235
▪ Distribution cabinets	64	▪ TacoFlow2 eLink (Innovation)	240
▪ Mixing station Universal	67	Heating and cooling circuit pumps	243
▪ Mixing station TacoSys	70	▪ TacoFlow3 MAX (Innovation)	243
▪ TopMeter Plus	73	▪ TacoFlow3 MAX PRO (Innovation)	250
▪ TopMeter Supply	75	Circulation pumps for solar thermal systems	257
▪ TopMeter Return	77	▪ TacoFlow2 SOLAR (ES2 Solar)	257
Actuators, room thermostats and wiring modules	80	DHW circulation pumps for potable water systems	262
▪ TacoDrive	82	▪ TacoFlow2 PURE (C) (ES2 Pure)	262
▪ NovaDrive NC / NO	86	▪ TacoFlow2 PURE (Innovation)	265
▪ TopDrive NC	89		
▪ NovaStat EL NovaMaster EL	92		
▪ NovaStat RF NovaMaster RF	96		
SYSTEM TECHNOLOGY	100		
Heat interface units	102		
▪ TacoTherm Dual Piko	106		
▪ TacoTherm Fresh/Dual Nano	122		
Fresh hot water stations	132		
▪ TacoTherm Fresh Mega3	134		
▪ TacoTherm Fresh Mega3 X	139		
▪ TacoTherm Fresh Peta2	144		
▪ TacoTherm Fresh Peta2 X	149		
▪ Plate heat exchanger requirements	154		
Storage loading stations	155		
▪ TacoSol Load Mega	157		
Solar stations	160		
▪ TacoSol Circ ER HE	162		
▪ TacoSol Circ ZR HE	165		
Heating circuit pump assembly	170		
▪ TacoHeat Mix	172		



OVERVIEW OF PRODUCTS AND APPLICATION AREAS

	Heating & cooling generation				Heating & cooling distribution					Sani- tation	Other	
	Geothermal energy	Solar thermal energy	Oil, gas, biomass, electricity	District heating	Radiators	Underfloor heating	Concrete core	Chilled and heated ceilings	Fan Coils, Chill Beams	Fresh water	Watering (garden, air/water)	Industrial applications
HYDRONIC BALANCING												
TacoSetter Bypass 100												
TacoSetter Bypass Solar 130												
TacoSetter Bypass Solar 185												
TacoSetter Bypass Flange												
TacoSetter Inline 100												
TacoSetter Inline 130												
TacoSetter Rondo												
TacoSetter Hyline												
TacoSetter Tronic												
TacoControl FlowMeter												
AREA HEATING SYSTEMS												
TacoSys Pro												
TacoSys HighEnd												
TacoSys Connect												
TopMeter Plus												
TopMeter Supply												
TopMeter Return												
TacoDrive												
NovaDrive NC / NO												
TopDrive NC												
NovaStat EL NovaMaster EL												
NovaStat RF NovaMaster RF												
SYSTEM TECHNOLOGY												
TacoTherm Dual Piko												
TacoTherm Fresh/Dual Nano												
TacoTherm Fresh Mega3 (X)												
TacoTherm Fresh Peta2 (X)												
TacoSol Load Mega (L)												
TacoSol Circ ER HE												
TacoSol Circ ZR HE												
TacoHeat Mix												

	Heating & cooling generation				Heating & cooling distribution					Sanitation	Other	
	Geothermal energy	Solar thermal energy	Oil, gas, biomass, electricity	District heating	Radiators	Underfloor heating	Concrete core	Chilled and heated ceilings	Fan Coils, Chill Beams	Fresh water	Watering (garden, air/water)	Industrial applications
VALVES AND ACCESSORIES												
NovaMix Value 50 FS												
NovaMix Value 65 FS												
NovaMix Value 70 FS												
NovaMix Standard												
NovaMix High Capacity												
NovaMix Compact												
NovaZone Ball												
NovaZone Valve												
TriBloc												
TacoVent Vent												
TacoVent HyVent												
TacoVent AirScoop DH												
TacoVent AirScoop DV												
PUMP TECHNOLOGY												
TacoFlow2 (C A)												
TacoFlow2 ADAPT												
TacoFlow2 eLink												
TacoFlow3 MAX												
TacoFlow3 MAX PRO												
TacoFlow2 SOLAR												
TacoFlow2 PURE												

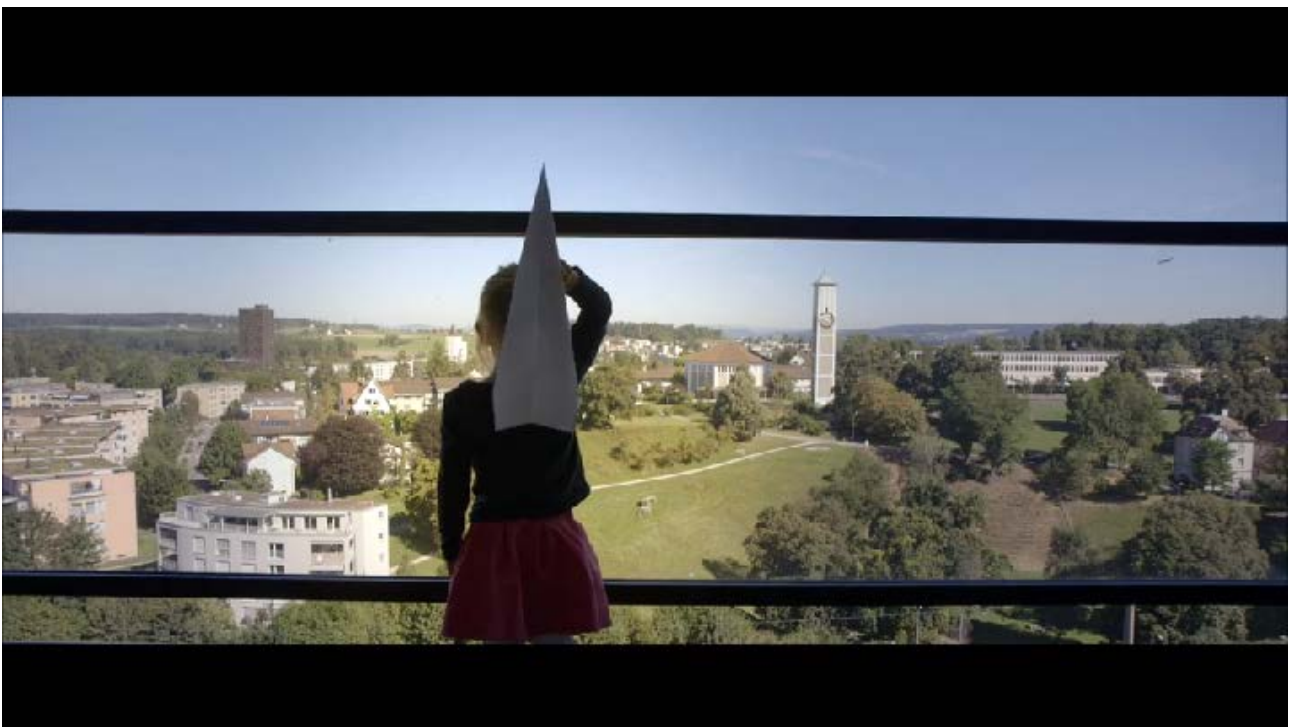

HYDRONIC BALANCING

In hydraulic heating and cooling systems, the energy carrier is transported over piping sections of different lengths. On the path from the energy generator to the consumer, pipe lengths and turns, branches, valves and heat exchangers present their own resistance that inhibits flow through their cross-sections and surface roughness.

Energy in buildings must be distributed in such a way that all building sections, rooms and consumers are optimally supplied according to their needs. A balanced system avoids excess and wasteful supply of consumer circuits and prevents irritating flow noises in the pipes and valves. The gain in comfort due to pleasant room temperatures and significantly increased energy efficiency are the perceptible and measurable results of hydronically balanced flow systems.

FREQUENTLY ASKED QUESTIONS



Here you will find the 10 most frequently asked questions and the corresponding answers from the field of hydronic balancing.



ESSENTIAL FOR MODERN BUILDING SERVICES

Hydronic balancing – the core area of expertise of Taconova – is part of the modern standard and is indispensable in the building service solutions of today. Hydronic balancing is promoted in different countries with subsidies. It is often legally prescribed for new buildings and refurbishment.

OVERVIEW OF PRODUCT GROUPS



THE ORIGINAL

The TacoSetter Bypass, referred to in the branch as just «TacoSetter», is the classic model of balancing valves. The popular and reliable original for static hydronic balancing indicates the flow volume by means of a scale directly in a bypass test object or in the valve/accessories. Along with the standard version, there are also solar versions with greater temperature resistance (up to 185 °C).



THE MULTITALENTED MODEL

TacoSetter Inline is the multitasking model of the balancing valves. It can be used to directly adjust, indicate and shut off the flow. The valve is used for underfloor heating, heating circuit distributors, sanitary systems, cooling circuits, heat pumps and solar systems.



THE COMPACT MODEL

TacoSetter Rondo saves on space and impresses with its functional design. It is suitable for direct installation in the flow or return directions of radiators or manifold bars, and enables uncomplicated adjustment of the volume flow without valve tables. With a measuring and control range of 0.6 – 8 l/min it has been designed for systems with small pipe dimensions.



THE PLASTIC SETTER

The new TacoSetter Hyline was developed in Switzerland and consists of high-quality, glass fiber-reinforced plastic. Thanks to its standard inch threads, the new plastic setter also enables installation without the need for additional adapters or tools.



THE HYBRID MODEL

TacoSetter Tronic is a balancing valve with a shut-off function. The valve also enables digital volume flow and temperature measurements. It monitors drinking water, solar and heating systems and supplies accurate data to the electronic system controller. It is suitable for volume flows of 1 – 40 l/min.



PRECISE MODEL

The TacoControl flow meter indicates the volume of water flowing in heating, ventilation, air-conditioning and sanitary systems easily and comfortably. The compact design of the TacoControl flow meter makes installation of a volume flow display, even in tight spaces.

OPTIMUM SUPPLY IS THE TARGET

In order to achieve equally distributed heat appropriate to the surrounding conditions, the calculated volume flows are limited to the flow values that correspond to the relevant rated heat requirement. As a result, radiators, surface heating systems and other consumers in the building can be supplied as required.

NON-BALANCED SYSTEM

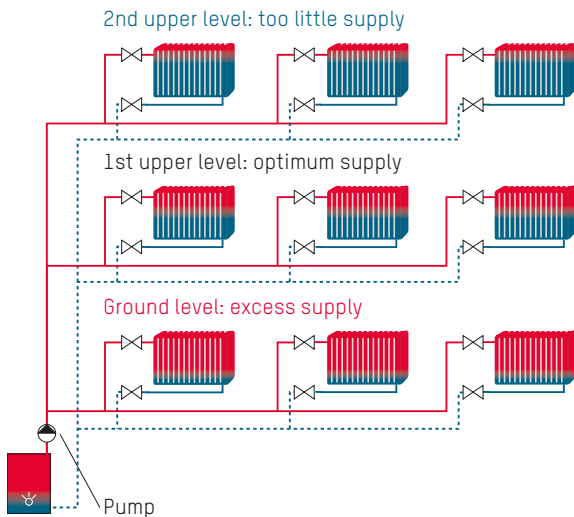

NON-BALANCED SYSTEM

The example of a water heating system with radiators shows that a non-balanced heating system can be directly felt due to the indoor temperatures: while radiators closer to the central heating system are overly supplied, the radiators located further away receive inadequate flow volumes.

This means that the radiators on higher floor levels are not supplied enough hot water: they are too cool or respond only slowly.

This deficiency is often compensated in practise with greater pump power, but this leads to flow noises in the system and inefficiently operated energy generators. The result is increased energy consumption for pumps and energy generation.

HYDRONICALLY BALANCED SYSTEM

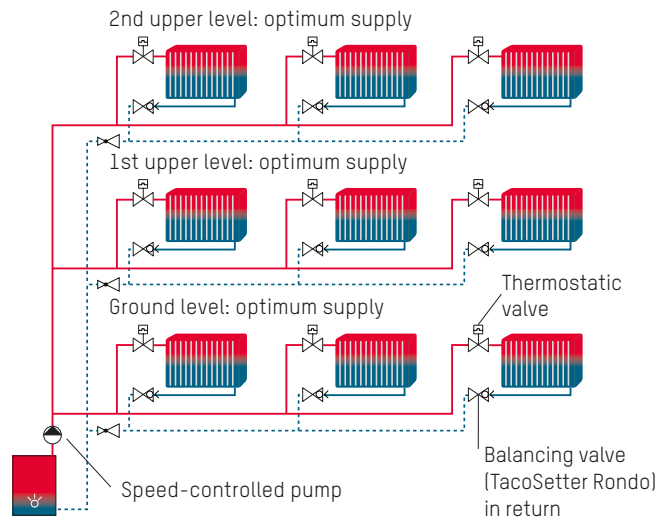

HYDRONICALLY-BALANCED SYSTEM

Balanced hydraulics are necessary to optimally use energy to obtain the specified flow and return temperatures. As a consequence of the static hydronic balancing, the required flow volumes are adjusted in such a way that all consumers in the building are supplied as desired. In this way, the heat is equally distributed and the lower activity of the burner saves energy. The interaction between a hydraulically balanced system and the requirement-based configuration of the consumers enables economic operation of the heat generator, particularly in regard to condensing heating technology and heat pumps.

BALANCING OF EXISTING HEATING SYSTEMS

The optimised distribution of heat in existing heating systems can save a large amount of energy. And that is an ecological and economic demand of our time. National specifications apply to the hydronic balancing of existing heating systems. In some cases there are also financial incentives.

STRAND BALANCING OF HEATING SYSTEMS WITH RADIATORS OR UNDERFLOOR HEATING

To perform hydronic balancing, the corresponding rated volume flows of the system and the individual piping sections must be known. While the calculation results of pipe dimensioning for new systems provide this data for adjustment, this information is usually unavailable for existing systems. For this reason, the rated volume flows must first be calculated on the basis of the rated heat requirement or thermal output of the available heating surfaces and on the temperature difference (between the flow and return water) of the heating system.

The required rated volume flows can be determined by means of a heating requirement calculation (DIN EN 12831).

DETERMINING VOLUME FLOWS ON THE BASIS OF THE CALCULATION OF HEATING REQUIREMENTS (DIN EN 12831)

The rated heating requirements of the individual rooms is obtained from the precise calculation of heat requirement. If this data is not available, the available heating surfaces (radiators or underfloor heating) can be included with the formulae from Taconova (download from taconova.com). The exact thermal output of the heating surfaces included in this way can be determined using manufacturers' documentation. The required volume flows are calculated on the basis of the temperature difference, the calculated specific heating requirement and the specific heating capacity of the carrier medium (typically water).

FIVE STEPS: THE EASIEST POSSIBLE WAY

Hydronic balancing of piping is very easy to carry out with the TacoSetter valves. The required volume flow in l/min must be known and set – that's all!





OPTIMIZING THE ENTIRE SYSTEM THROUGH HYDRONIC BALANCING

A perfectly adjusted heating system ensures an even level of heat at all locations. This increases comfort, reduces CO₂ emissions and cuts energy consumption.

BENEFITS AT THE PLANNING STAGE

- Simplest system design and installation control
- Planning certainty and compliance with the relevant regulations and standards in heating and sanitary planning
- Product safety thanks to durable European valves and accessories

BENEFITS AT THE INSTALLATION STAGE

- Time-saving regulation of flow rates without any need for conversion
- Simple control of flow rates during maintenance and testing without requiring measurement devices
- Simple implementation of static hydronic balancing for existing systems
- Compact regulation in pipe installations

QUALITY VALVES

Taconova offers all the valves that are needed for optimal implementation of a hydraulic balance system. Allowing complete line balancing of high-pressure circuits which provides quick and easy planning, and thus the economic operation of the plant.

Balancing Valves	
<p>The classic models in the TacoSetter and TopMeter family guarantee the desired flow rates in heating systems, as well as in cooling, solar energy and saline water distribution systems. The flow volume can be directly checked at a glance at any time with these balancing valves – with one exception: the TacoSetter Tronic, which measures the flow rate electronically</p>	<ul style="list-style-type: none"> ▪ TacoSetter Bypass 100 ▪ TacoSetter Bypass Solar 130/185 ▪ TacoSetter Bypass Flange ▪ TacoSetter Inline 100/130 ▪ TacoSetter Rondo ▪ TacoSetter Tronic ▪ TacoSetter Hyline

APPLICATIONS

Taconova offers a seamless portfolio of high-quality balancing and measurement valves for a wide range of diverse applications.

Heating and cooling energy generation	Heating and cooling energy distribution (indoor temperature control)	Sanitary systems
<ul style="list-style-type: none"> ▪ Solar thermal energy ▪ Geothermal energy ▪ Oil, gas, electricity, biomass ▪ District heating 	<ul style="list-style-type: none"> ▪ Underfloor heating ▪ Radiators ▪ Chilled and heated ceilings ▪ Fan coils and chill beams ▪ Concrete cores 	<ul style="list-style-type: none"> ▪ Fresh water

THE RIGHT PRODUCT FOR EVERY VOLUME FLOW

Setter	Order number	0,3	0,6	1	1,5	2	4	6	8	10	15	20	30	40	50	60	70	80	90	100	200	300	400	500	600	700
--------	--------------	-----	-----	---	-----	---	---	---	---	----	----	----	----	----	----	----	----	----	----	-----	-----	-----	-----	-----	-----	-----

TacoSetter Bypass 100



223.22X2.XXX																											
223.23X1.000																											
223.23X0.XXX																											
223.23X2.XXX																											
223.24X0.XXX																											
223.24X1.XXX																											
223.25X1.XXX																											
223.26X1.XXX																											
223.28X1.XXX																											

TacoSetter Bypass Solar 130/185



223.238X.XXX																											
223.238X.XXX																											
223.248X.XXX																											
223.2580.000																											

TacoSetter Bypass Flange



223.2151.000																											
223.2251.000																											
223.2351.000																											

TacoSetter Inline 100



223.1202.000																											
223.12X3.XXX																											
223.12X4.XXX																											
223.12X8.XXX																											
223.12X9.XXX																											
223.1300.000																											
223.1302.000																											
223.1305.000																											

THE RIGHT PRODUCT FOR EVERY VOLUME FLOW

Order number

Setter	Bestell-Nr.	0,3	0,6	1	1,5	2	4	6	8	10	15	20	30	40	50	60	70	80	90	100	200	300	400	500	600	700
--------	-------------	-----	-----	---	-----	---	---	---	---	----	----	----	----	----	----	----	----	----	----	-----	-----	-----	-----	-----	-----	-----

TacoSetter Inline 130



223.7556.334					1,5 – 6 l/min																						
223.7566.334						4 – 16 l/min																					
223.7576.334										8 – 28 l/min																	
223.7586.000										10 – 40 l/min																	
223.7234.104					1 – 3,5 l/min																						
223.7238.104						2 – 8 l/min																					
223.7318.000					1,5 – 7,5 l/min																						
223.7310.000						4 – 15 l/min																					
223.7312.000										10 – 30 l/min																	
223.7370.000						4 – 15 l/min																					
223.7378.000										10 – 45 l/min																	
223.7427.000												20 – 90 l/min															
223.7457.000												20 – 90 l/min															
223.7467.000												20 – 90 l/min															

TacoSetter Rondo



223.3206.XXX					0 – 8 l/min																						
--------------	--	--	--	--	-------------	--	--	--	--	--	--	--	--	--	--	--	--	--	--	--	--	--	--	--	--	--	--

TacoSetter Hyline



223.8410.000										10 – 25 l/min																	
223.8411.000											15 – 40 l/min																
223.8412.000												20 – 60 l/min															
223.8523.000												20 – 55 l/min															
223.8524.000													30 – 80 l/min														

TacoSetter Tronic



223.7702.000					1 – 12 l/min																						
223.7704.000						2 – 40 l/min																					

TACOSSETTER BYPASS 100

BALANCING VALVE

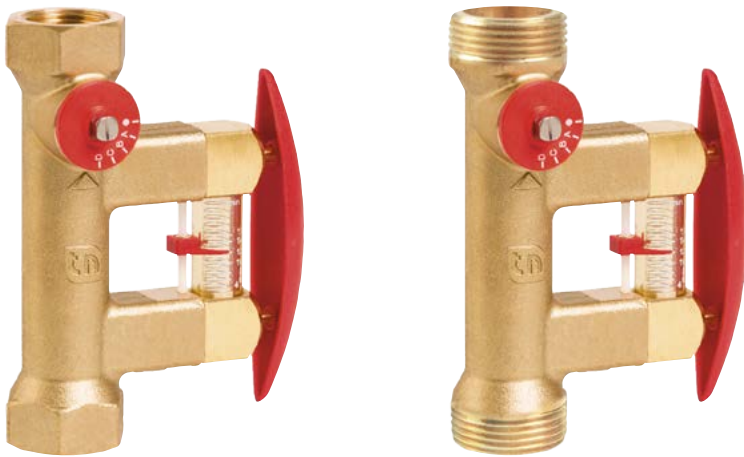

Direct regulation, indication and isolation of flows in systems.

DESCRIPTION

Direct hydraulic balancing and control of flows to consumers or in a subsystem. Balancing valves offer an easy and accurate method of adjusting the flow rates for heating-, ventilation-, air conditioning- and cooling systems.

Correct balancing of hydraulic circuits ensures optimum energy distribution, resulting in more efficient and economical operation in accordance with the energy saving regulations provided for by legislation.

With TacoSetter Bypass balancing valves, any qualified fitter can set the appropriate flow rate using the unique flow measurement device, avoiding investments in training and costly measuring devices.

INSTALLATION POSITION

The TacoSetter Bypass 100 requires a straight section of pipe of the same length and diameter as the system. The valve can be installed in a horizontal, vertical or inclined position. Care should be taken that the arrow is pointing in the direction of the flow.

ADVANTAGES

- Accurate and fast adjustment with scale and without the aid of diagrams, tables or measurement devices
- Direct reading of the set volume flow in l/min
- Variable installation position, maintenance-free
- Flow control with setpoint adjuster
- Regulating valve with isolating facility (rest leakage possible)
- Minimal pressure loss

OPERATION

The flow measurement is based on the principle of a baffle float with return spring. The reading position is the bottom line of the baffle float. The measuring device is placed in a bypass to the main flow, isolated from system flow. By demand the bypass, with self locking valves, gets opened / closed by pressing / releasing the clamp. Reading the flow rate has no influence on the main flow rate.

BUILDING CATEGORIES

For pipe installations in drinking water, heating and cooling area:

- Apartment blocks, housing estates, multiple dwelling units
- Residential care facilities, hospitals
- Administration and service buildings
- Hotels and restaurants, industrial kitchens
- School buildings and sports facilities
- Commercial and industrial buildings
- Facilities with partial use, such as barracks, camping sites

SYSTEM/BASIC DIAGRAM

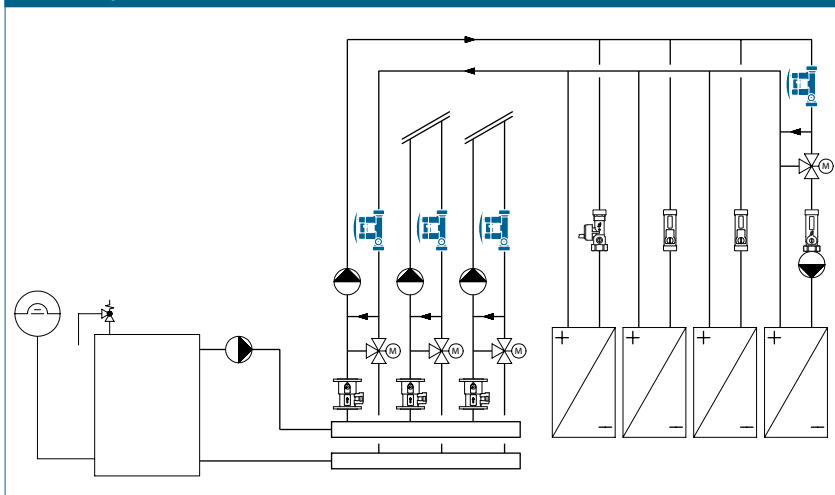

SPECIFICATION TEXT

See www.taconova.com

TECHNICAL DATA

General

- Operating temperature $T_{0\text{ max}}$: 100 °C
- Operating pressure $P_{0\text{ max}}$: 10 bar
- Measuring accuracy:
 - Measurement range 20 – 80%: $\pm 5\%$ of the indicated value
 - Measurement range <20% / >80%: $\pm 10\%$ of the indicated value
- k_{VS} value and measurement range see «Type overview»
- Female thread (cylindrical) to DIN 2999 / ISO 7 or male thread G (cylindrical) to ISO 228

Material

- Housing: brass
- Inside: stainless steel, brass, plastic
- Sight glass: heat- and impact resistant plastic
- Seals: EPDM

Fluids

- Heating water (VDI 2035; SWKI BT 102-01; ÖNORM H 5195-1)
- Potable water (DIN 1988-200)
- Water and proprietary additives used against corrosion and freezing up to 50% (see document «Correction curves»)

APPROVALS / CERTIFICATES

- ACS

ADDITIONAL MODELS

Setter for solar applications, see data sheets TacoSetter Bypass Solar 130 and TacoSetter Bypass Solar 185. Complete sets with insulation box are available for the TacoSetter Bypass 100 (see our „Range of Products“ catalog and our „Price List“).

GLYCOL CORRECTION CURVES

There is a separate diagram for TacoSetter up to DN25 and its flow ranges with nine correction curves for use of anti-frost and anti-corrosion agents. Corrections are not required for larger dimensions as the deviation lies within the measuring tolerance. See www.taconova.com

TYPE OVERVIEW

TacoSetter Bypass 100 | Balancing valve with female thread

Order no.	DN	Rp × Rp	Measuring range	k_{VS} (m ³ /h)
223.2262.000	15	½" × ½"	2 – 8 (l/min)	1,95
223.2361.000	20	¾" × ¾"	2 – 8 (l/min)	1,95
223.2360.000	20	¾" × ¾"	4 – 15 (l/min)	3,3
223.2362.000	20	¾" × ¾"	8 – 30 (l/min)	5,0
223.2460.000	25	1" × 1"	6 – 20 (l/min)	5,1
223.2461.000	25	1" × 1"	10 – 40 (l/min)	8,1
223.2561.000	32	1 ¼" × 1 ¼"	20 – 70 (l/min)	17,0
223.2661.000	40	1 ½" × 1 ½"	30 – 120 (l/min)	30,0
223.2861.000	50	2" × 2"	50 – 200 (l/min)	54,0

TacoSetter Bypass 100 | Balancing valve with male thread

Order no.	DN	G × G	Measuring range	k_{VS} (m ³ /h)
223.2272.000	20	1" × 1"	2 – 8 (l/min)	2,2
223.2370.000	20	1" × 1"	4 – 15 (l/min)	3,3
223.2372.000	20	1" × 1"	8 – 30 (l/min)	5,0
223.2470.000	25	1 ¼" × 1 ¼"	6 – 20 (l/min)	5,1
223.2471.000	25	1 ¼" × 1 ¼"	10 – 40 (l/min)	8,1
223.2571.000	32	1 ½" × 1 ½"	20 – 70 (l/min)	17,0

DIMENSIONAL DRAWING

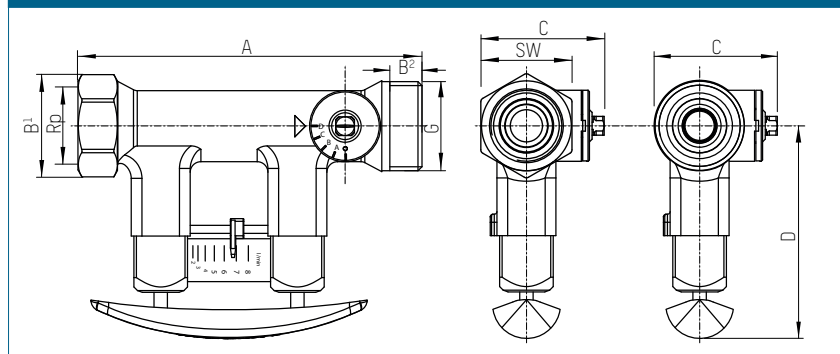

MEASUREMENT TABLE

TacoSetter Bypass 100 | Balancing valve with female thread

Order no.	DN	A	B ¹	C	D	SW	Rp
223.2262.000	15	142	39	46	79	34	½"
223.2361.000	20	129	39	46	79	34	¾"
223.2360.000	20	129	39	46	79	34	¾"
223.2362.000	20	129	39	46	79	34	¾"
223.2460.000	25	152	47	58	82	41	1"
223.2461.000	25	152	47	58	82	41	1"
223.2561.000	32	161	56	65	84	49	1 ¼"
223.2661.000	40	173	64	79	90	59	1 ½"
223.2861.000	50	197	76	91	97	70	2"

TacoSetter Bypass 100 | Balancing valve with male thread

Order no.	DN	A	B ²	C	D	G
223.2272.000	20	129	12	46	79	1"
223.2370.000	20	129	12	46	79	1"
223.2372.000	20	129	12	46	79	1"
223.2470.000	25	152	15	58	82	1 ¼"
223.2471.000	25	152	15	58	82	1 ¼"
223.2571.000	32	161	15	65	84	1 ½"

PRESSURE LOSS DIAGRAMS

223.2262.000 (DN 15 | ½" | 2...8 l/min)
 223.2361.000 (DN 20 | ¾" | 2...8 l/min)
 223.2272.000 (DN 20 | 1" | 2...8 l/min)

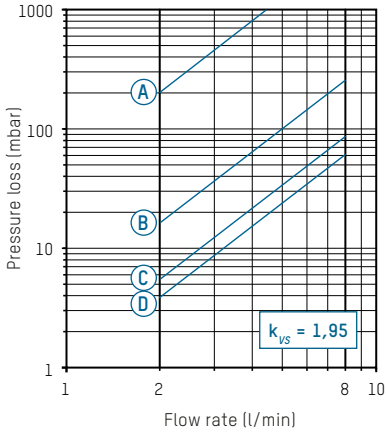

A - D Valve position

223.2360.000 (DN 20 | ¾" | 4...15 l/min)
 223.2370.000 (DN 20 | 1" | 4...15 l/min)

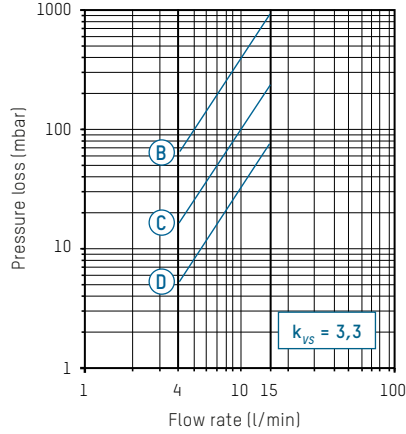

B - D Valve position

223.2362.000 (DN 20 | ¾" | 8...30 l/min)
 223.2372.000 (DN 20 | 1" | 8...30 l/min)

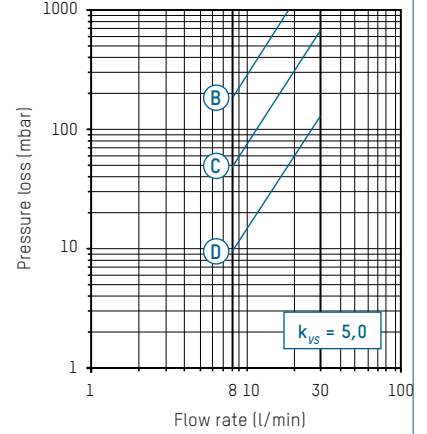

B - D Valve position

223.2460.000 (DN 25 | 1" | 6...20 l/min)
 223.2470.000 (DN 25 | 1¼" | 6...20 l/min)

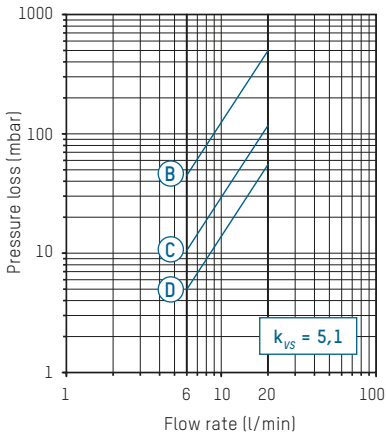

B - D Valve position

223.2461.000 (DN 25 | 1" | 10...40 l/min)
 223.2471.000 (DN 25 | 1¼" | 10...40 l/min)

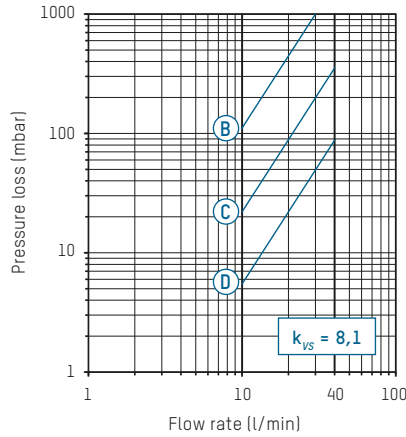

B - D Valve position

223.2561.000 (DN 32 | 1¼" | 20...70 l/min)
 223.2571.000 (DN 32 | 1½" | 20...70 l/min)

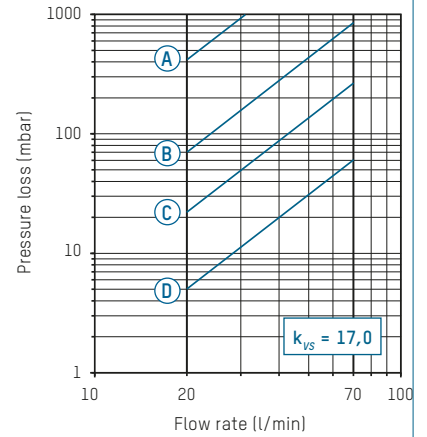

A - D Valve position

223.2661.000 (DN 40 | 1½" | 30...120 l/min)

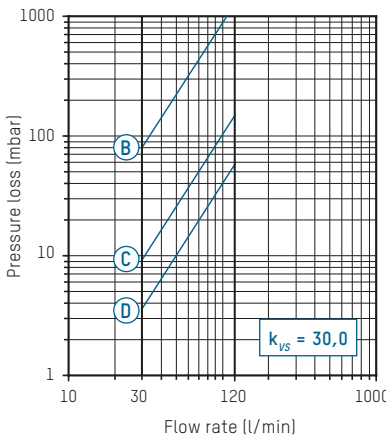

B - D Valve position

223.2861.000 (DN 50 | 2" | 50...200 l/min)

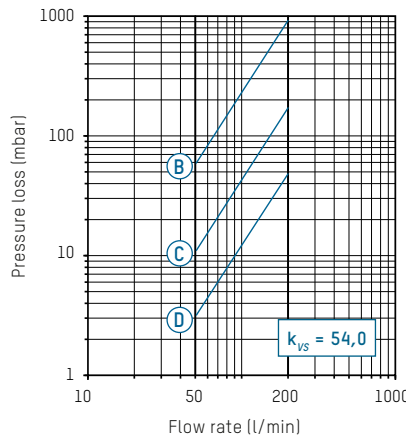

B - D Valve position

ACCESSORIES



INSULATION BOX

EPP, T₀ -30 – 130 °C, in accordance with EnEV guideline

Order no.	Fits to
296.2321.004	DN 15 + DN 20
296.2322.004	DN 25
296.2323.004	DN 32
296.2324.004	DN 40
296.2325.004	DN 50



SYSTEM SCREW CONNECTION FITS TO TACOSSETTER BYPASS

Screw connection with male thread R (conical) as per DIN 2999

Order no.	G × R	Version for	Fits to
210.6630.000	¾" × ½"	Threaded pipe Rp ¾"	DN 15
210.6631.000	1" × ½"	Threaded pipe Rp ¾"	DN 15
210.6632.000	1" × ¾"	Threaded pipe Rp ¾"	DN 20
210.6633.000	1¼" × 1"	Threaded pipe Rp 1"	DN 25



Screw connection with solder connection

Order no.	G x mm	Version for	Fits to
210.5331.019	1" x 18	Copper pipe ø 18 mm	DN 15 (Male)
210.5332.019	1" x 22	Copper pipe ø 22 mm	DN 20 (Male)
210.5334.003	1¼" x 28	Copper pipe ø 28 mm	DN 25 (Male)

SPARE PARTS



SIGHT GLASS (COMPLETE) AND SEAL

Order no.	Range	Fits to
298.2333.020	2 – 8 (l/min)	223.2262.000 / 223.2272.000
298.2334.020	4 – 15 (l/min)	223.2360.000 / 223.2370.000
298.2335.020	8 – 30 (l/min)	223.2362.000 / 223.2372.000
298.2342.020	6 – 20 (l/min)	223.2460.000 / 223.2470.000
298.2343.020	10 – 40 (l/min)	223.2461.000 / 223.2471.000
298.2352.020	20 – 70 (l/min)	223.2561.000 / 223.2571.000
298.2362.020	30 – 120 (l/min)	223.2661.000
298.2382.020	50 – 200 (l/min)	223.2861.000

TACOSSETTER BYPASS SOLAR 130

BALANCING VALVE

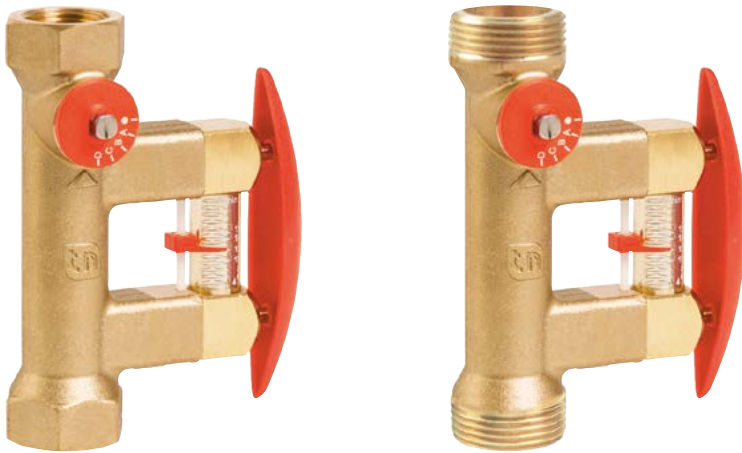

ADVANTAGES

- Accurate and fast adjustment with scale and without the aid of diagrams, tables or measurement devices
- Direct reading of the set volume flow in l/min
- Temperature-resistant up to 130 °C
- Variable installation position, maintenance-free
- Flow control with setpoint adjuster
- Regulating valve with isolating facility (rest leakage possible)
- Minimal pressure loss

Direct regulation, indication and isolation of flows in solar systems

DESCRIPTION

Direct hydraulic balancing and control of flows to consumers or in a sub-system. TacoSetter Bypass Solar 130 balancing valves offer an easy and accurate method of adjusting the flow rates for heating-, ventilation-, air conditioning- and cooling systems.

Correct balancing of hydraulic circuits ensures optimum energy distribution, resulting in more efficient and economical operation in accordance with the energy saving regulations provided for by legislation.

With TacoSetter Bypass Solar 130 balancing valves, any qualified fitter can set the appropriate flow rate using the unique flow measurement device, avoiding investments in training and costly measuring devices.

INSTALLATION POSITION

The TacoSetter Bypass Solar 130 requires a straight section of pipe of the same length and diameter as the system. The valve can be installed in a horizontal, vertical or inclined position.

Care should be taken that the arrow is pointing in the direction of the flow.

OPERATION

The flow measurement is based on the principle of a baffle float with return spring. The reading position is the bottom line of the baffle float. The measuring device is placed in a bypass to the main flow, isolated from system flow. By demand the bypass, with self locking valves, gets opened / closed by pressing / releasing the clamp. Reading the flow rate has no influence on the main flow rate.

BUILDING CATEGORIES

For pipe installations in drinking water, heating and cooling area:

- Apartment blocks, housing estates, multiple dwelling units
- Residential care facilities and hospitals
- Administration and service buildings
- Hotels and restaurants, industrial kitchens
- School buildings and sports facilities
- Commercial and industrial buildings
- Facilities with partial use, such as barracks, camping sites

SYSTEM/BASIC DIAGRAM

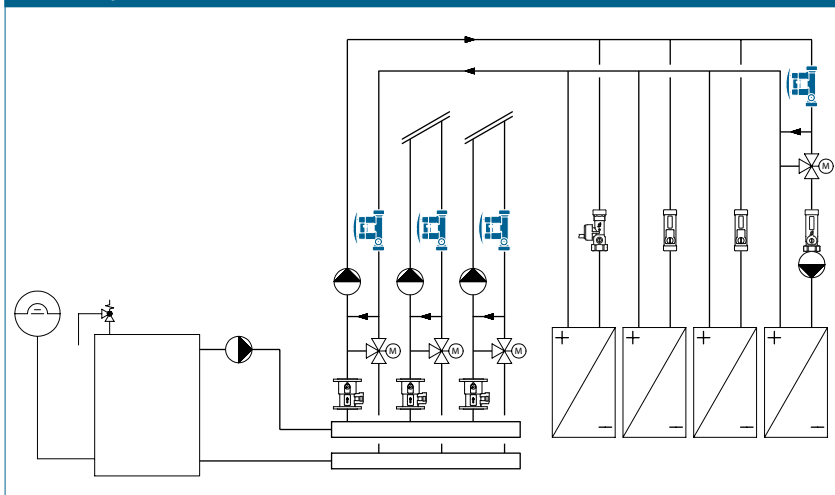

SPECIFICATION TEXT

See www.taconova.com

TECHNICAL DATA

General

- Max. temperature and pressure range: $T_{0\ max}$ and $P_{0\ max}$:
See pressure-temperature curve
- Measuring accuracy:
 - Measuring range <25%:
 $\pm 20\%$ of the indicated value
 - Measuring range >25%:
 $\pm 10\%$ of the indicated value
- k_{VS} value and measurement range see "Type overview"
- Female thread to DIN 2999 / ISO 7 or male thread G (cylindrical) to ISO 228

Material

- Housing: brass
- Inside: stainless steel, brass, plastic
- Sight glass: plastic
- Seals: EPDM

Fluids

- Heating water (VDI 2035; SWKI BT 102-01; ÖNORM H 5195-1)
- Water and proprietary additives used against corrosion and freezing up to 50% (see document «Correction curves»)

ADDITIONAL MODELS

Balancing valves for other applications, see data sheets TacoSetter Bypass 100 and TacoSetter Bypass Solar 185.

TYPE OVERVIEW

TacoSetter Bypass Solar 130 | Balancing valve with female thread

Order no.	DN	Rp × Rp	Measuring range	k_{VS} (m ³ /h)
223.2380.000	20	¾" × ¾"	2 – 12 (l/min)	2,2
223.2381.000	20	¾" × ¾"	8 – 20 (l/min)	5,0
223.2482.000	25	1" × 1"	10 – 40 (l/min)	8,1

TacoSetter Bypass Solar 130 | Balancing valve with male thread

Order no.	DN	G × G	Measuring range	k_{VS} (m ³ /h)
223.2380.350	20	1" × 1"	2 – 12 (l/min)	2,2
223.2381.350	20	1" × 1"	8 – 20 (l/min)	5,0
223.2482.350	25	1 ¼" × 1 ¼"	10 – 40 (l/min)	8,1

DIMENSIONAL DRAWING

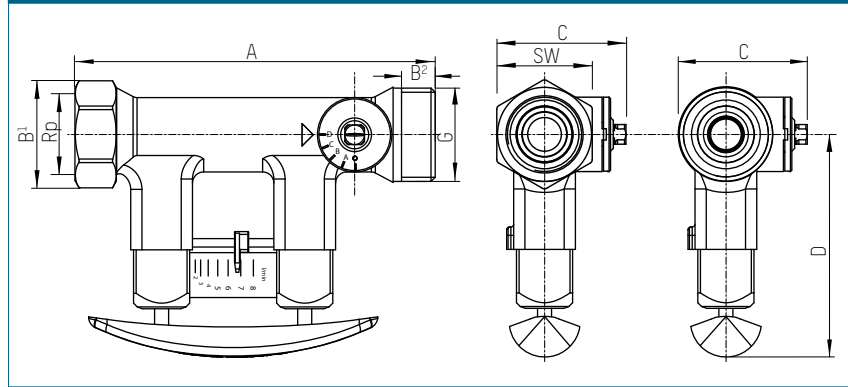

MEASUREMENT TABLE

TacoSetter Bypass Solar 130 | Balancing valve with female thread

Order no.	DN	A	B ¹	C	D	SW	Rp
223.2380.000	20	129	39	46	79	34	¾"
223.2381.000	20	129	39	46	79	34	¾"
223.2482.000	25	152	47	58	82	41	1"

TacoSetter Bypass Solar 130 | Balancing valve with male thread

Order no.	DN	A	B ²	C	D	G
223.2380.350	20	129	12	46	79	1"
223.2381.350	20	129	12	46	79	1"
223.2482.350	25	152	15	58	82	1 ¼"

GLYCOL CORRECTION CURVES

There is a separate diagram for TacoSetter up to DN25 and its flow ranges with nine correction curves for use of anti-frost and anti-corrosion agents. Corrections are not required for larger dimensions as the deviation lies within the measuring tolerance. See www.taconova.com

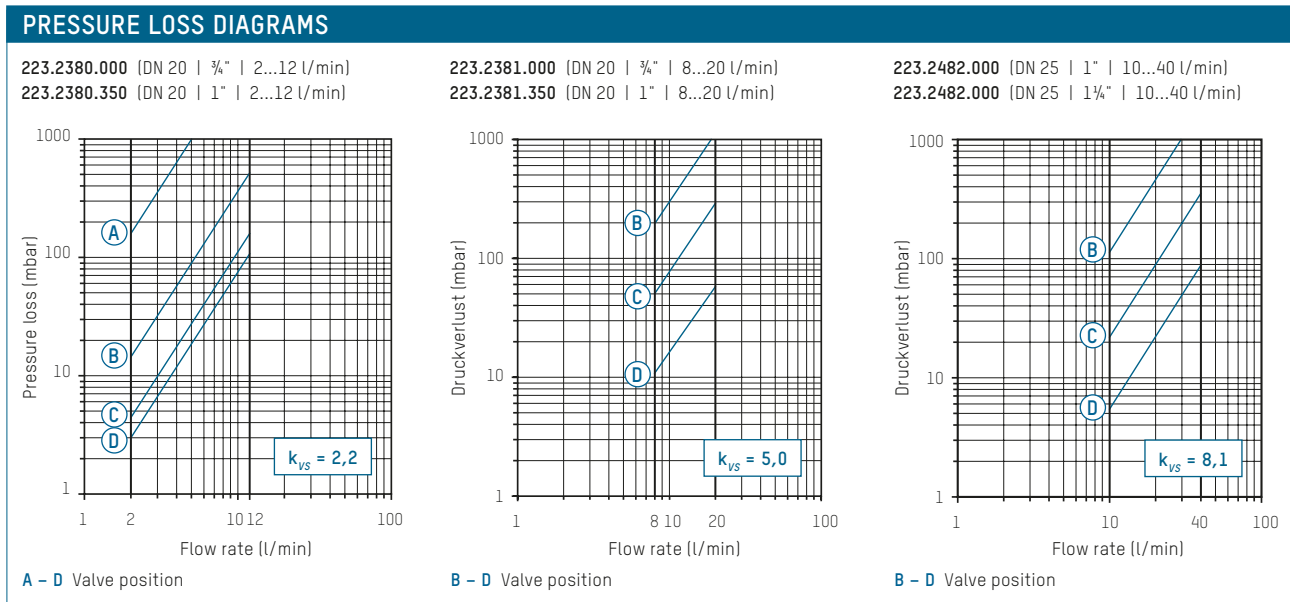
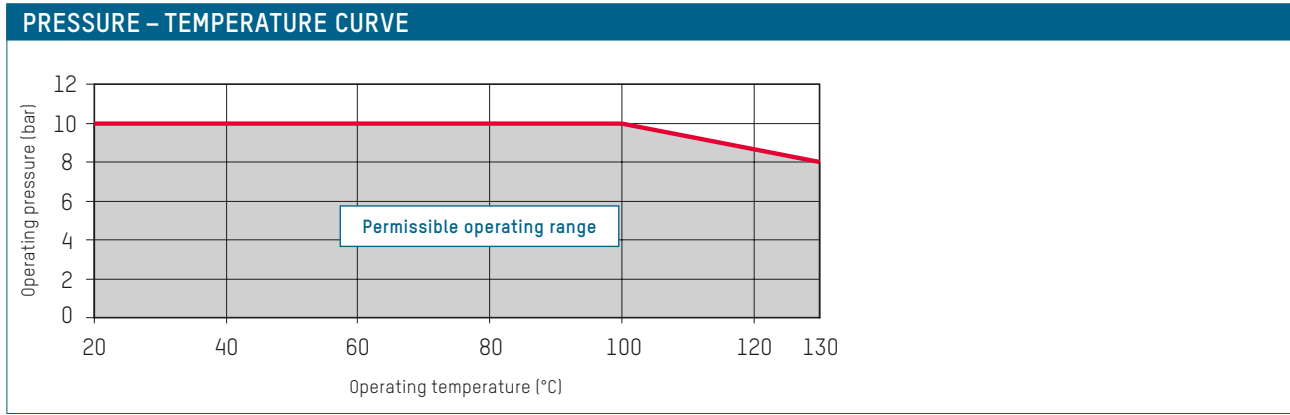

ACCESSORIES



INSULATION BOX

EPP, T₀ -30 – 130 °C, in accordance with EnEV guideline

Order no.	Fits
296.2321.004	DN 20
296.2322.004	DN 25



SYSTEM SCREW CONNECTION FITS TO TACOSSETTER BYPASS SOLAR 130

Screw connection with male thread R (conical) as per DIN 2999

Order no.	G x R	Version for	Fits to
210.6630.000	¾" x ½"	Inner thread Rp ½"	DN 15
210.6631.000	1" x ½"	Inner thread Rp ½"	DN 15
210.6632.000	1" x ¾"	Inner thread Rp ¾"	DN 20
210.6633.000	1¼" x 1"	Inner thread Rp 1"	DN 25



Screw connection with solder connection

Order no.	G x mm	Version for	Fits to
210.5331.019	1" x 18	Copper pipe ø 18 mm	DN 15 (Male)
210.5332.019	1" x 22	Copper pipe ø 22 mm	DN 20 (Male)
210.5334.003	1¼" x 28	Copper pipe ø 28 mm	DN 25 (Male)

SPARE PARTS



SIGHT GLASS (COMPLETE) AND SEALS

Order no.	Range	Fits to
298.2336.020	2 – 12 (l/min)	223.2380.000 / 223.2380.350
298.2337.020	8 – 20 (l/min)	223.2381.000 / 223.2381.350
298.2344.020	10 – 40 (l/min)	223.2482.000 / 223.2482.350

TACOSSETTER BYPASS SOLAR 185

BALANCING VALVE



ADVANTAGES

- Accurate and fast adjustment with scale and without the aid of diagrams, tables or measurement devices
- Direct reading of the set volume flow in l/min
- Temperature-resistant up to 185 °C
- Variable installation position, maintenance-free
- Flow control with setpoint adjuster
- Regulating valve with isolating facility (rest leakage possible)
- Minimal pressure loss

Direct regulation, indication and isolation of flows in solar systems.

DESCRIPTION

Direct hydraulic balancing and control of flows to consumers or in a subsystem. Balancing valves offer an easy and accurate method of adjusting the flow rates for heating-, ventilation-, air conditioning - and solar systems.

The Version TacoSetter Bypass Solar 185 is designed for higher operating temperatures.

Correct balancing of hydraulic circuits ensures optimum energy distribution, resulting in more efficient and economical operation in accordance with the energy saving regulations provided for by legislation.

With TacoSetter Bypass Solar 185 balancing valves, any qualified fitter can set the appropriate flow rate using the unique flow measurement device, avoiding investments in training and costly measuring devices.

INSTALLATION POSITION

The TacoSetter Bypass Solar 185 requires a straight section of pipe of the same length and diameter as the system. The valve can be installed in a horizontal, vertical or inclined position. Care should be taken that the arrow is pointing in the direction of the flow.

In the case of the high-temperature type, the bypass unit is replaced by the sealing cap set after adjustment.

OPERATION

The flow measurement is based on the principle of a baffle float with return spring. The reading position is the bottom line of the baffle float. The measuring device is placed in a bypass to the main flow, isolated from system flow. By demand the bypass, with self locking valves, gets opened / closed by pressing / releasing the clamp. Reading the flow rate has no influence on the main flow rate.

BUILDING CATEGORIES

For pipe installations in heating and cooling area:

- Apartment blocks, housing estates, multiple dwelling units
- Residential care facilities and hospitals
- Administration and service buildings
- Hotels and restaurants, industrial kitchens
- School buildings and sports facilities
- Commercial and industrial buildings
- Facilities with partial use, such as barracks, camping sites

SYSTEM/BASIC DIAGRAM

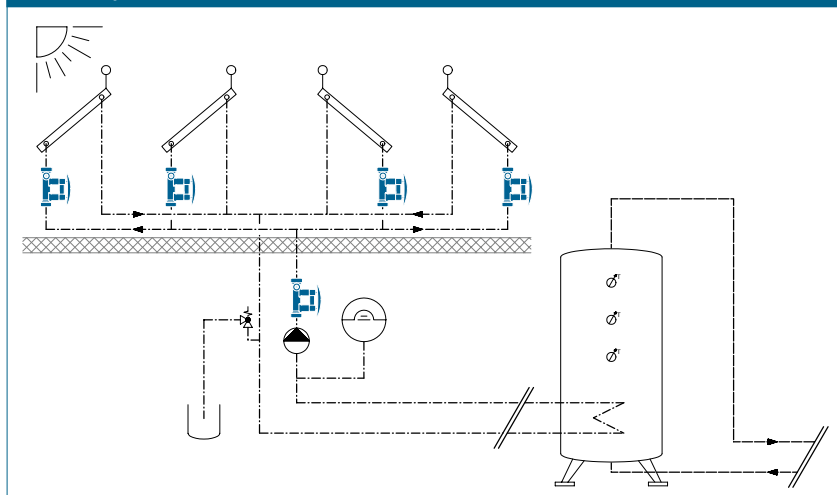

SPECIFICATION TEXT

See www.taconova.com

TECHNICAL DATA

General

- Admissible operating parameters
 $T_{0\max}$ und $P_{0\max}$: see pressure temperature curve
- Measuring accuracy:
 - Measurement range <25%:
 $\pm 20\%$ of the indicated value
 - Measurement range >25%:
 $\pm 10\%$ of the indicated value
- k_{VS} value and measurement range: see "Type Program"
- Female thread to DIN 2999 / ISO 7 or male thread G (cylindrical) to ISO 228

Material

- Housing: brass
- Inside: stainless steel, brass, plastic
- Sight glass: heat- and impact-resistant plastic
- Sealing: EPDM

Fluids

- Heating water (VDI 2035; SWKI BT 102-01; ÖNORM H 5195-1)
- Water and proprietary additives used against corrosion and freezing up to 50% (see document «Correction curves»)

ADDITIONAL MODELS

Balancing valves for solar applications, see TacoSetter Bypass 100 and TacoSetter Bypass Solar 130 data sheets.

TYPE OVERVIEW

TacoSetter Bypass Solar 185 | Balancing valve with female thread (incl. sealing cap set)

Order no.	DN	Rp × Rp	Measuring range	k_{VS} (m ³ /h)
223.2382.000	20	¾" × ¾"	2 – 12 (l/min)	2,2
223.2383.000	20	¾" × ¾"	8 – 30 (l/min)	5,0
223.2480.000	25	1" × 1"	10 – 40 (l/min)	8,1
223.2580.000	32	1¼" × 1¼"	20 – 70 (l/min)	17,0

TacoSetter Bypass Solar 185 | Balancing valve with male thread (incl. sealing cap set)

Order no.	DN	G × G	Measuring range	k_{VS} (m ³ /h)
223.2382.385	20	1" × 1"	2 – 12 (l/min)	2,2
223.2383.385	20	1" × 1"	8 – 30 (l/min)	5,0

DIMENSIONAL DRAWING

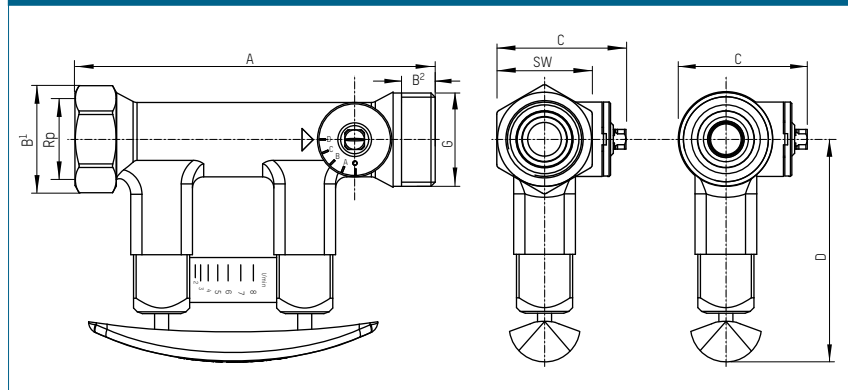

MEASUREMENT TABLE

TacoSetter Bypass Solar 185 | Balancing valve with female thread

Order no.	DN	A	B ¹	C	D	SW	Rp
223.2382.000	20	129	39	46	79	34	¾"
223.2383.000	20	129	39	46	79	34	¾"
223.2480.000	25	152	47	58	82	41	1"
223.2580.000	32	161	56	65	84	49	1"

TacoSetter Bypass Solar 185 | Balancing valve with male thread

Order no.	DN	A	B ²	C	D	G
223.2382.385	20	129	12	46	79	1"
223.2383.385	20	129	12	46	79	1"

GLYCOL CORRECTION CURVES

There is a separate diagram for TacoSetter up to DN25 and its flow ranges with nine correction curves for use of anti-frost and anti-corrosion agents.

Corrections are not required for larger dimensions as the deviation lies within the measuring tolerance.

See www.taconova.com

PRESSURE - TEMPERATURE-CHARACTERISTIC

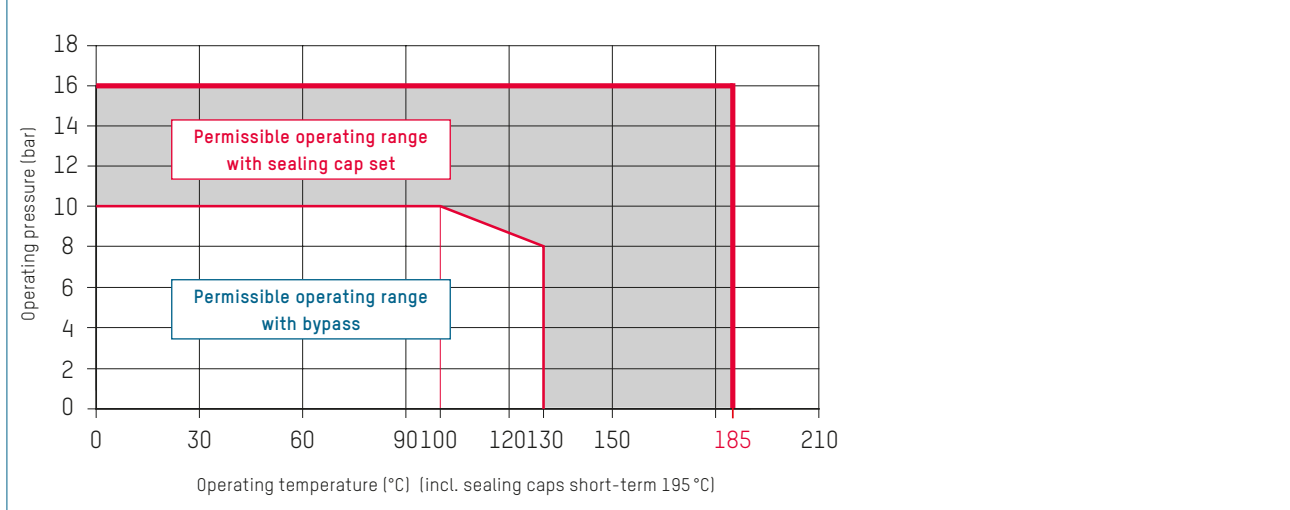

PRESSURE LOSS DIAGRAMS

223.2382.XXX (DN 20 | 3/4" | 2...12 l/min)

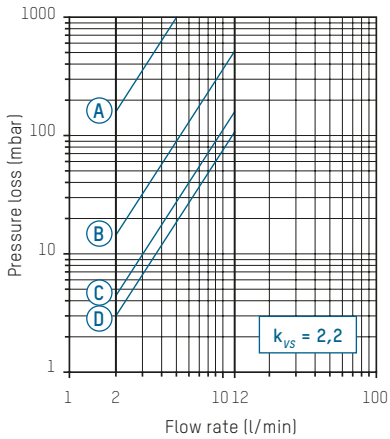

223.2383.XXX (DN 20 | 3/4" | 8...30 l/min)

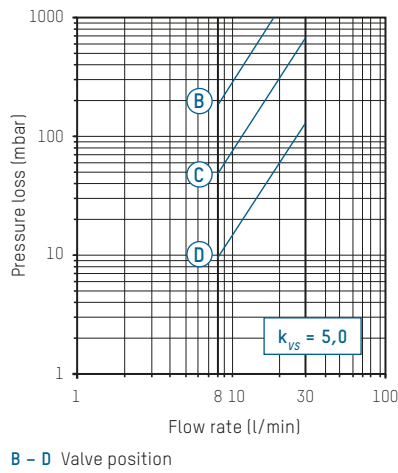

223.2480.XXX (DN 25 | 1" | 10...40 l/min)

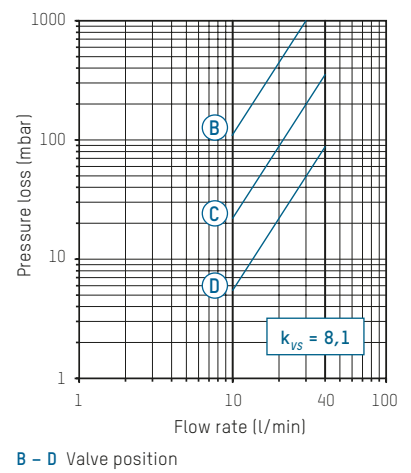

223.2580.000 (DN 32 | 1 1/4" | 20...70 l/min)

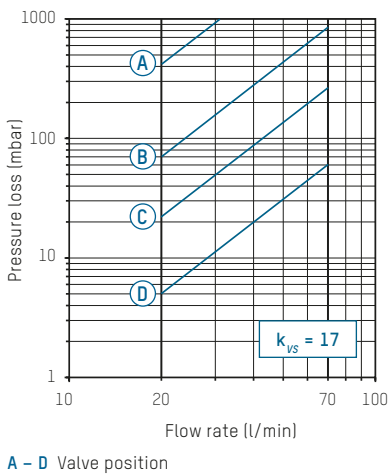

ACCESSORIES



SYSTEM SCREW CONNECTION FITS TO TACOSSETTER BYPASS

Screw connection with male thread R (conical) as per DIN 2999

Order no.	G x R	Version for	Fits to
210.6630.000	¾" x ½"	Threaded pipe Rp ½"	DN 15
210.6631.000	1" x ½"	Threaded pipe Rp ½"	DN 15
210.6632.000	1" x ¾"	Threaded pipe Rp ¾"	DN 20
210.6633.000	1¼" x 1"	Threaded pipe Rp 1"	DN 25

Screw connection with solder connection

Order no.	G x mm	Version for	Fits to
210.5331.019	1" x 18	Copper pipe ø 18 mm	DN 15 AG
210.5332.019	1" x 22	Copper pipe ø 22 mm	DN 20 AG
210.5334.003	1¼" x 28	Copper pipe ø 28 mm	DN 25 AG

SPARE PARTS



SIGHT GLASS (COMPLETE) AND SEAL

Order no.	Range	Fits to
298.2336.020	2 - 12 (l/min)	223.2380.000 / 223.2380.350
298.2337.020	8 - 20 (l/min)	223.2381.000 / 223.2381.350
298.2338.020	8 - 30 (l/min)	223.2383.000 / 223.2383.385
298.2344.020	10 - 40 (l/min)	223.2482.000 / 223.2482.350



SEALING CAP SET FOR TACOSSETTER BYPASS 130/185

Order no.	Fits to
296.2340.003	all versions

Included with delivery for Solar 185 model

TACOSSETTER BYPASS FLANGE

BALANCING VALVE



Direct reading and balancing valve with visual flow indication.

DESCRIPTION

Direct hydraulic balancing and control of flows to consumers or in a subsystem. TacoSetter Bypass Flange balancing valves offer an easy and accurate method of adjusting the flow rates for heating-, ventilation-, air conditioning- and cooling systems. Correct balancing of hydraulic circuits ensures optimum energy distribution, resulting in more efficient and economical operation in accordance with the energy saving regulations provided for by legislation. With TacoSetter Bypass Flange balancing valves, any qualified fitter can set the appropriate flow rate using the unique flow measurement

device, avoiding investments in training and costly measuring devices.

INSTALLATION

To avoid turbulence and obtain maximum accuracy of the required flow it is necessary to install, on the inlet side of the valve, a section of straight pipe, the same diameter and length as the valve body. The valve may be installed in any position, care should be taken in order to ensure that both the measuring cylinder and adjustment screw are not obstructed and that the arrow is pointing in the direction of the flow.

ADVANTAGES

- Accurate and fast adjustment with scale and without the aid of diagrams, tables or measurement devices
- Direct reading of the set volume flow in l/min
- Variable installation position, maintenance-free
- Flow control with setpoint adjuster
- Regulating valve with isolating facility (rest leakage possible)
- Minimal pressure loss

OPERATION

Measurement of the flow rate through the valve can be set by turning the adjustment screw until the required flow rate is read on the front edge of the float, which is situated within the measuring cylinder. The two check valves must be in the open position but can be closed after commissioning without affecting the set position.

BUILDING CATEGORIES

- For pipe installations in heating water and cooling areas:
- Apartment blocks, housing estates, multiple dwelling units
 - Residential care facilities and hospitals
 - Administration and service buildings
 - School buildings and sports facilities
 - Commercial and industrial buildings

SYSTEM / BASIC DIAGRAM

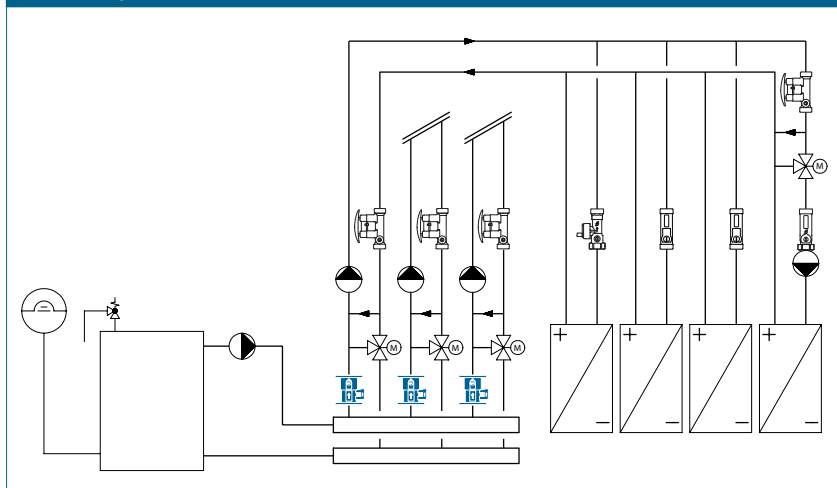

SPECIFICATION TEXT

See www.taconova.com

TECHNICAL DATA

Generally

- Operating temperature $T_{0\text{max}}$: 100 °C
- Operating pressure $P_{0\text{max}}$: 10 bar
- Measuring accuracy: ±5% of nominal flow
- k_{VS} -value and measurement range see «Type program»

Material

- Valve body: grey, cast iron
- Valve housing materials: brass
- Sight glass: heat- and impact resistant plastic
- Seals: EPDM

Fluids

- Heating water (VDI 2035; SWKI BT 102-01; ÖNORM H 5195-1)
- Water and proprietary additives used against corrosion and freezing up to 50%

TYPE PROGRAM

TacoSetter Bypass Flange | Balancing valve

Order no.	DN	Measuring range	Weight	k_{VS} (m ³ /h)
223.2151.000	65	60 – 325 (l/min)	13,9 kg	85,0
223.2251.000	80	75 – 450 (l/min)	16,5 kg	166,0
223.2351.000	100	100 – 650 (l/min)	19,7 kg	208,0

DIMENSIONAL DRAWING

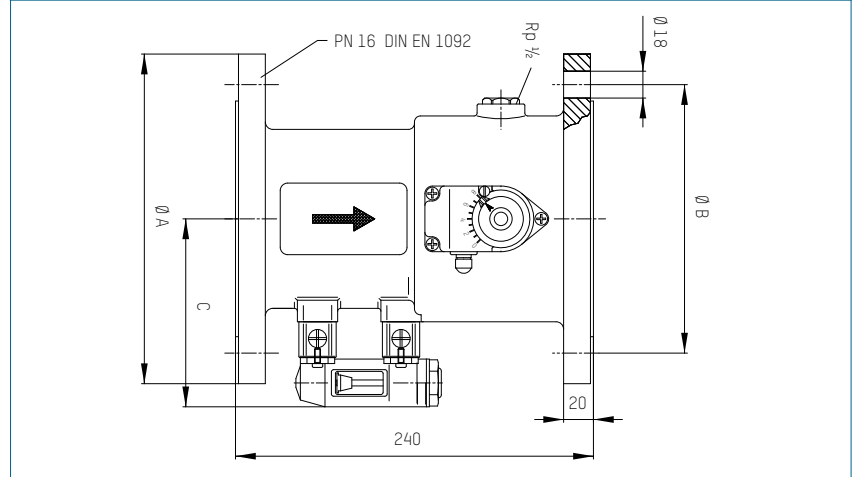

MEASUREMENT TABLE

TacoSetter Bypass Flange | Balancing valve

Order no.	DN	A	B	C	Ø 18
223.2151.000	65	185	145	110	4 holes
223.2251.000	80	200	160	118	8 holes
223.2351.000	100	220	180	128	8 holes

SPARE PARTS



SIGHT GLASS (COMPLETE) AND SEAL

Order no.	Range	Fits to
298.2321.000	60 – 325 (l/min)	223.2151.000
298.2322.000	75 – 450 (l/min)	223.2251.000
298.2323.000	100 – 650 (l/min)	223.2351.000

PRESSURE LOSS DIAGRAM

223.2151.000 (DN 65 | 60...325 l/min)

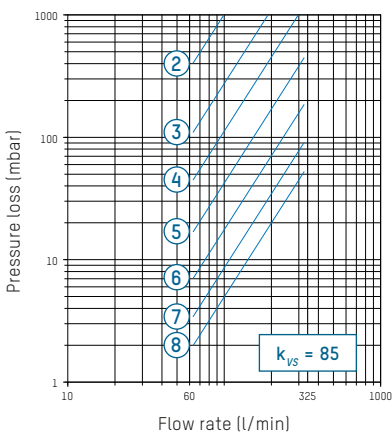

2 – 8 Valve position

223.2251.000 (DN 80 | 75...450 l/min)

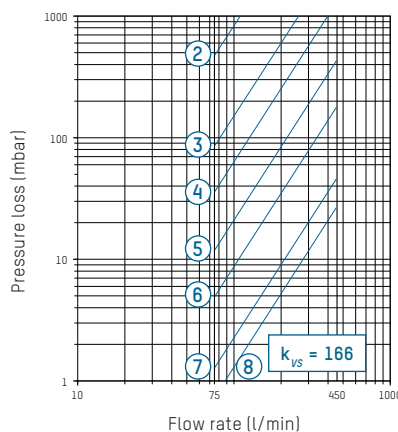

2 – 8 Valve position

223.2351.000 (DN 100 | 100...650 l/min)

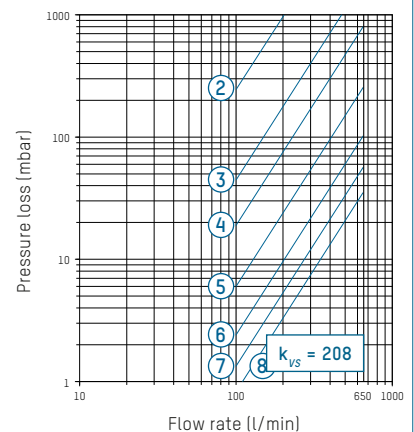

2 – 8 Valve position

TACOSSETTER INLINE 100

BALANCING VALVE



ADVANTAGES

- Accurate and fast adjustment with scale and without the aid of diagrams, tables or measurement devices
- Direct reading of the set volume flow in l/min
- Variable installation position, maintenance-free
- Regulating valve with isolating facility (rest leakage possible)
- Additional types are also available as make resistant to dezincification

Direct regulation, reading and shut-off of flows in systems

DESCRIPTION

Direct hydraulic balancing and control of flows to consumers or in a sub-system.

Balancing valves offer a quick, easy and accurate method of adjusting the flow rates through heating, ventilation, air conditioning and cooling systems.

Correct balancing of hydraulic circuits ensures optimum energy distribution, resulting in more efficient and economical operation in accordance with the energy saving regulations provided for by legislation.

With TacoSetter Inline 100 balancing valves, any qualified fitter can set the appropriate flow rate using the unique flow measurement device,

avoiding investments in training and costly measuring devices.

INSTALLATION POSITION

The valve can be installed in a horizontal, vertical or inclined position. Care should be taken that the arrow is pointing in the direction of the flow.

OPERATION

The flow measurement is based on the principle of a baffle float with return spring. The flowmeter is built into the housing.

The balancing can be carried out with a screwdriver at the adjusting screw. The reading position is the bottom line of the baffle float.

BUILDING CATEGORIES

For pipe installations in drinking water, heating and cooling area:

- Apartment blocks, housing estates, multiple dwelling units
- Residential care facilities and hospitals
- Administration and service buildings
- Hotels and restaurants, industrial kitchens
- School buildings and sports facilities
- Commercial and industrial buildings
- Facilities with partial use, such as barracks, camping sites

SYSTEM/BASIC DIAGRAM

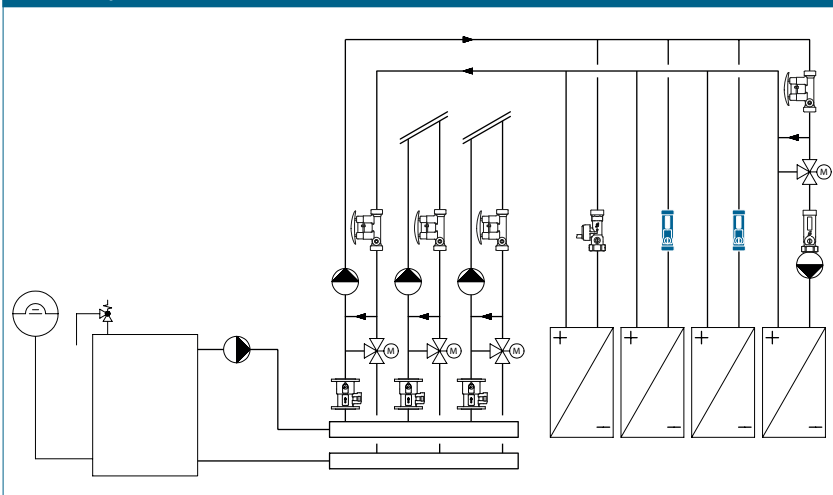

SPECIFICATION TEXT

See www.taconova.com

TECHNICAL DATA

General

- Operating temperature $T_{0\max}$: 100 °C
- Operating pressure $P_{0\max}$: 10 bar
- Measuring accuracy: $\pm 10\%$ of the indicated value
- k_{VS} value and measurement range see «Type overview»
- Connections:
 - $\frac{3}{4}$ " euro cone
 - $\frac{1}{2}$ " female thread acc. to DIN 2999
 - 1" thread G (flat-sealing) acc. to ISO 228

Material

- Housing: see «Type overview»
- Sight glass: heat- and impact resistant plastic
- Seals: EPDM

Fluids

- Heating water (VDI 2035; SWKI BT 102-01; ÖNORM H 5195-1)
- Potable water (DIN 1988-200)
- Water and proprietary additives used against corrosion and freezing up to 50% (see document «Correction curves»)

APPROVALS / CERTIFICATES

- KTW, W270, ACS

TYPE OVERVIEW

TacoSetter Inline 100 | Balancing valve made of brass with female thread

Order no.	DN	G × Rp	Measuring range	k_{VS} (m ³ /h)
223.1202.000	15	$\frac{3}{4}$ " × $\frac{1}{2}$ "	0,3 – 1,5 (l/min)	0,25
223.1203.000	15	$\frac{3}{4}$ " × $\frac{1}{2}$ "	0,6 – 2,4 (l/min)	0,6
223.1204.000	15	$\frac{3}{4}$ " × $\frac{1}{2}$ "	1,0 – 3,5 (l/min)	1,35
223.1208.000	15	$\frac{3}{4}$ " × $\frac{1}{2}$ "	2,0 – 8,0 (l/min)	1,8
223.1209.000	15	$\frac{3}{4}$ " × $\frac{1}{2}$ "	3,0 – 12,0 (l/min)	1,85

TacoSetter Inline 100 | Balancing valve made of brass with male thread

Order no.	DN	G × G	Measuring range	k_{VS} (m ³ /h)
223.1233.000	15	$\frac{3}{4}$ " × $\frac{3}{4}$ "	0,6 – 2,4 (l/min)	0,6
223.1234.000	15	$\frac{3}{4}$ " × $\frac{3}{4}$ "	1,0 – 3,5 (l/min)	1,35
223.1238.000	15	$\frac{3}{4}$ " × $\frac{3}{4}$ "	2,0 – 8,0 (l/min)	1,8
223.1239.000	15	$\frac{3}{4}$ " × $\frac{3}{4}$ "	3,0 – 12,0 (l/min)	1,85
223.1300.000	20	1" × 1"	4,0 – 15,0 (l/min)	5,0
223.1302.000	20	1" × 1"	8,0 – 30,0 (l/min)	5,0
223.1305.000	20	1" × 1"	10,0 – 40,0 (l/min)	5,0

TacoSetter Inline 100 | Balancing valve made of dezincification-resistant (DZR) brass with female thread

Order no.	DN	G × Rp	Measuring range	k_{VS} (m ³ /h)
223.1204.104	15	$\frac{3}{4}$ " × $\frac{1}{2}$ "	1,0 – 3,5 (l/min)	1,35
223.1208.104	15	$\frac{3}{4}$ " × $\frac{1}{2}$ "	2,0 – 8,0 (l/min)	1,8
223.1209.104	15	$\frac{3}{4}$ " × $\frac{1}{2}$ "	3,0 – 12,0 (l/min)	1,85

TacoSetter Inline 100 | Balancing valve made of dezincification-resistant (DZR) brass with male thread

Order no.	DN	G × G	Measuring range	k_{VS} (m ³ /h)
223.1232.104	15	$\frac{3}{4}$ " × $\frac{3}{4}$ "	0,3 – 1,5 (l/min)	0,25
223.1233.104	15	$\frac{3}{4}$ " × $\frac{3}{4}$ "	0,6 – 2,4 (l/min)	0,6
223.1234.104	15	$\frac{3}{4}$ " × $\frac{3}{4}$ "	1,0 – 3,5 (l/min)	1,35
223.1238.104	15	$\frac{3}{4}$ " × $\frac{3}{4}$ "	2,0 – 8,0 (l/min)	1,8

GLYCOL CORRECTION CURVES

There is a separate diagram for TacoSetter up to DN25 and its flow ranges with nine correction curves for use of anti-frost and anti-corrosion agents. Corrections are not required for larger dimensions as the deviation lies within the measuring tolerance. See www.taconova.com

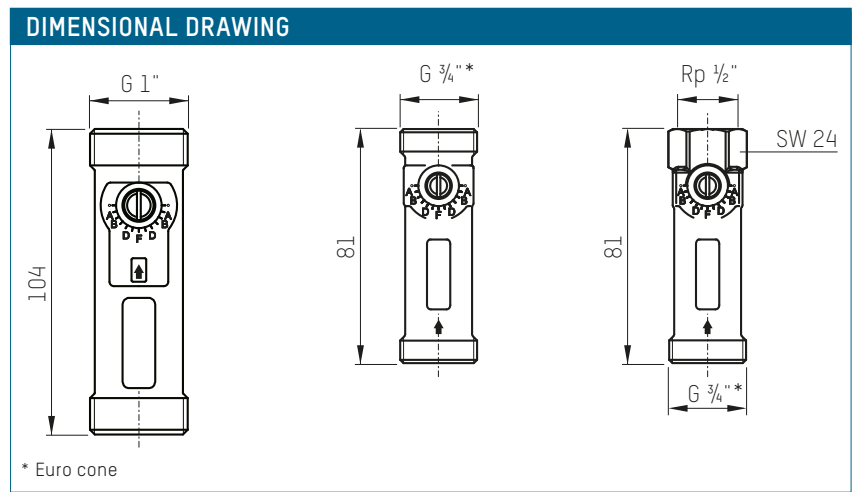

PRESSURE LOSS DIAGRAMS

223.1202.000 (DN 15 | 0,3...1,5 l/min)
223.1232.104 (DN 15 | 0,3...1,5 l/min)

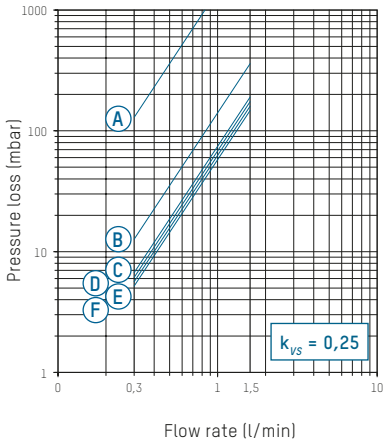

A – F Valve position

223.1203.000 (DN 15 | 0,6...2,4 l/min)
223.1233.XXX (DN 15 | 0,6...2,4 l/min)

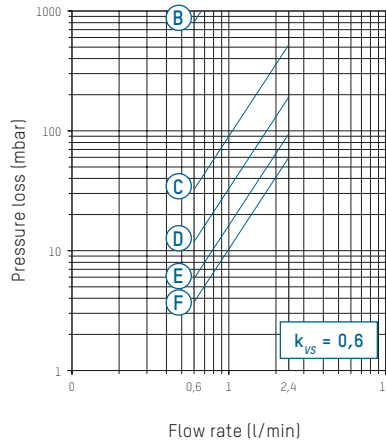

B – F Valve position

223.1204.XXX (DN 15 | 1,0...3,5 l/min)
223.1234.XXX (DN 15 | 1,0...3,5 l/min)

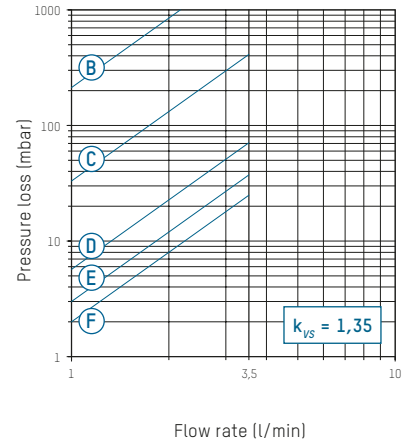

B – D Valve position

223.1208.XXX (DN 15 | 2...8 l/min)
223.1238.XXX (DN 15 | 2...8 l/min)

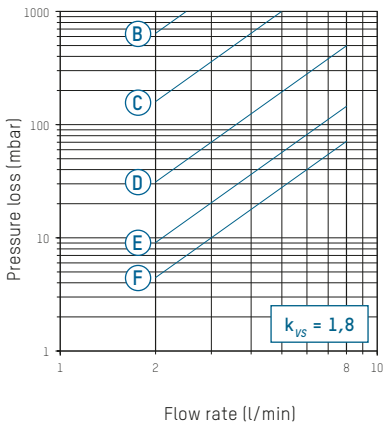

B – F Valve position

223.1209.XXX (DN 15 | 3...12 l/min)
223.1239.000 (DN 15 | 3...12 l/min)

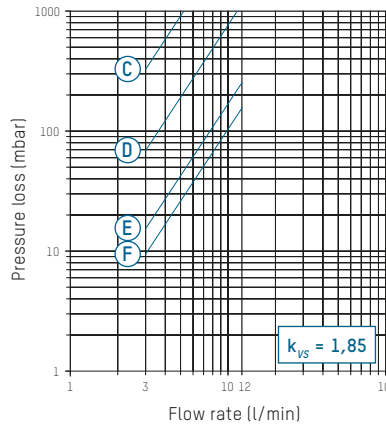

C – F Valve position

223.1300.000 (DN 20 | 4...15 l/min)

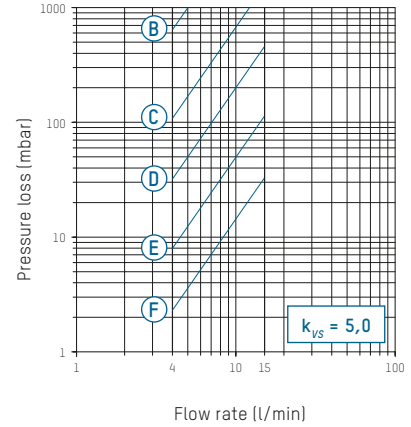

C – F Valve position

223.1302.000 (DN 20 | 8...30 l/min)
223.1305.000 (DN 20 | 10...40 l/min)

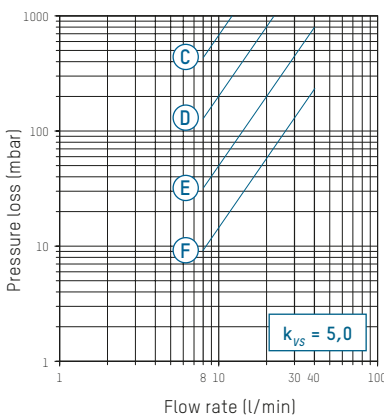

C – F Valve position

ACCESSORIES



SYSTEM SCREW CONNECTION FITS TO TACOSSETTER INLINE

Comprising a cap nut, clamp ring and support sleeve

Order no.	G × mm	Version for	Fits to
210.3325.000	3/4" × 15	Copper pipe 15/1 Eurocone	DN 15



Screw connections with cap nut and insert

Order no.	G × R	Version for	Fits to
210.6221.000	3/4" × 1/2"	1/2" thread, conically sealing, dezincification- resistant	DN 15
210.6632.000	1" × 3/4"	3/4" thread, flat-sealing	DN 20
210.6633.000	1 1/4" × 1"	1" thread, flat-sealing	DN 20
210.6222.000	3/4" × 1/2"	1/2" thread, self-sealing	DN 15

TACOSSETTER INLINE 130

BALANCING VALVE



ADVANTAGES

- Accurate and fast adjustment with scale and without the aid of diagrams, tables or measurement devices
- Direct reading of the set volume flow in l/min
- Temperature-resistant up to 130 °C
- Variable installation position, maintenance-free
- Regulating valve with isolating facility (rest leakage possible)

Direct regulation, indication and isolation of flows in systems.

DESCRIPTION

Direct hydraulic balancing and control of flows: TacoSetter Inline 130 balancing valves offer an easy and accurate method of adjusting the flow rates through heating, geothermal, ventilation, air conditioning and cooling systems.

Correct balancing of hydraulic circuits ensures optimum energy distribution, resulting in more efficient and economical operation in accordance with the energy saving regulations provided for by legislation.

With TacoSetter Inline 130 balancing valves, any qualified fitter can set the appropriate flow rate on the premises in question, thus avoiding investments in training and costly measuring devices.

INSTALLATION POSITION

The valve can be installed in a horizontal, vertical or inclined position. Care should be taken to ensure that the arrow is pointing in the direction of the flow.

The 3/4" version with union nut and Euro cone can be connected directly to an underfloor heating circuit. The version with 1" union nut directly to a circulation pump.

OPERATION

The flow measurement is based on the principle of a baffle float with return spring. The flowmeter is built into the housing.

The balancing can be carried out with a screwdriver at the adjusting screw. The reading position is the bottom line of the baffle float.

BUILDING CATEGORIES

For pipe installations in heating area:

- Apartment blocks, housing estates, multiple dwelling units
- Residential care facilities and hospitals
- Administration and service buildings
- Hotels and restaurants, industrial kitchens
- School buildings and sports facilities
- Commercial and industrial buildings
- Facilities with partial use, such as barracks, camping sites

SYSTEM/BASIC DIAGRAM

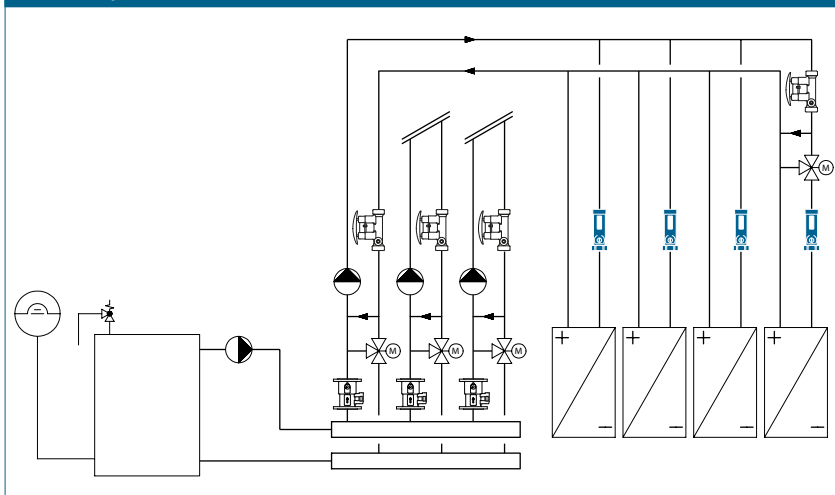

NOTE

Important when using glycol

The system medium must be allowed to flow through the measuring body for at least 2 hours prior to reading the flow rate when performing the initial start-up or refilling the system

SPECIFICATION TEXT

See www.taconova.com

TECHNICAL DATA

General

- Operating temperature $T_{0\max}$: 130 °C
- Operating pressure $P_{0\max}$: 10 bar
- Measuring accuracy: $\pm 10\%$ of the indicated value
- k_{VS} value and measurement range see «Type overview»
- Connections:
 - $\frac{3}{4}$ " euro cone
 - 1", 1 $\frac{1}{4}$ ", 1 $\frac{1}{2}$ " flat-sealing connector
- Thread G (cylindrical) acc. to ISO 228

Material

- Housing: see «Type overview»
- Inside: stainless steel, brass, plastic
- Sight glass: borosilicate
- Seals: EPDM
- Flat-sealing connections

Fluids

- Heating water (VDI 2035; SWKI BT 102-01; ÖNORM H 5195-1)
- Potable water (DIN 1988-200)
- Water and proprietary additives used against corrosion and freezing up to 50%

APPROVALS / CERTIFICATES

- KTW, W270

TYPE OVERVIEW

TacoSetter Inline 130 | Balancing valve made of dezincification-resistant (DZR) brass with male thread and euro cone (A)

Order no.	DN	G × G	Measuring range	k_{VS} (m ³ /h)
223.7234.104	15	$\frac{3}{4}$ " × $\frac{3}{4}$ "	1,0 – 3,5 (l/min)	1,35
223.7238.104	15	$\frac{3}{4}$ " × $\frac{3}{4}$ "	2,0 – 8,0 (l/min)	1,8

TacoSetter Inline 130 | Balancing valve made of brass with lock nut and euro cone (B)

Order no.	DN	G × G	Measuring range	k_{VS} (m ³ /h)
223.7318.000	20	$\frac{3}{4}$ " × $\frac{3}{4}$ "	2,0 – 8,0 (l/min)	1,6
223.7310.000	20	$\frac{3}{4}$ " × $\frac{3}{4}$ "	4,0 – 15,0 (l/min)	5,95
223.7312.000	20	$\frac{3}{4}$ " × $\frac{3}{4}$ "	10,0 – 30,0 (l/min)	6,6

TacoSetter Inline 130 | Balancing valve made of brass with cutting ring connection $\varnothing 22$ (C) (Also suitable for flat-sealing connection)

Order no.	DN	G × G	Measuring range	k_{VS} (m ³ /h)
223.7370.000	20	1" × 1"	4,0 – 15,0 (l/min)	5,95
223.7378.000	20	1" × 1"	10,0 – 45,0 (l/min)	6,85

TacoSetter Inline 130 | Balancing valve made of brass with male thread (D)

Order no.	DN	G × G	Measuring range	k_{VS} (m ³ /h)
223.7427.000	25	1" × 1"	20,0 – 90,0 (l/min)	17,0
223.7457.000	25	1 $\frac{1}{4}$ " × 1 $\frac{1}{4}$ "	20,0 – 90,0 (l/min)	17,0
223.7467.000	25	1 $\frac{1}{2}$ " × 1 $\frac{1}{2}$ "	20,0 – 90,0 (l/min)	17,0

TacoSetter Inline 130 | Balancing valve made of brass with lock nut and glycol scale (E)

Order no.	DN	G × G	Measuring range *	k_{VS} (m ³ /h)
223.7556.334	20	1" × 1"	1,5 – 6,0 (l/min)	1,8
223.7566.334	20	1" × 1"	4,0 – 16,0 (l/min)	4,76
223.7576.334	20	1" × 1"	8,0 – 28,0 (l/min)	5,44

* Reading scale for water-glycol mix with $\nu = 2,3 \text{ mm}^2/\text{s}$

TacoSetter Inline 130 | Balancing valve made of brass with lock nut and water scale (E)

Order no.	DN	G × G	Measuring range	k_{VS} (m ³ /h)
223.7586.000	20	1" × 1"	10,0 – 40,0 (l/min)	5,44

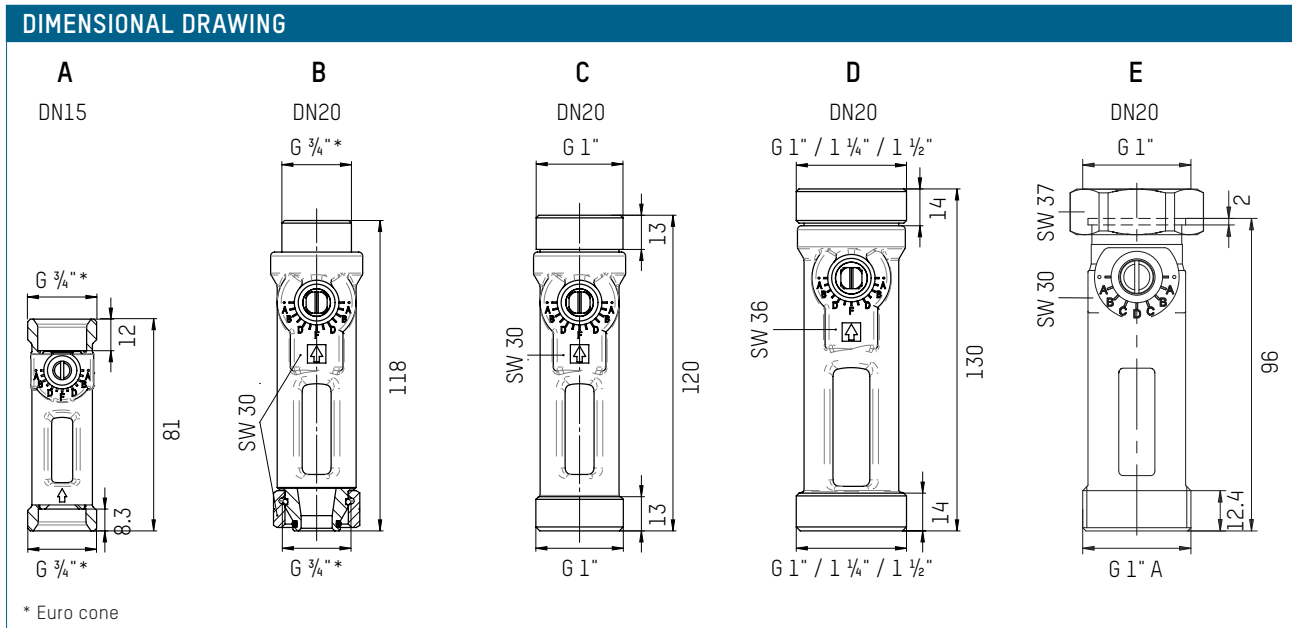

PRESSURE LOSS DIAGRAMS

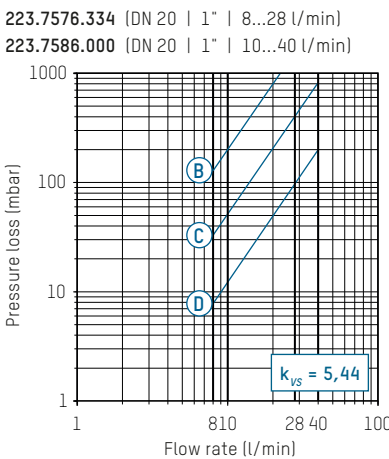
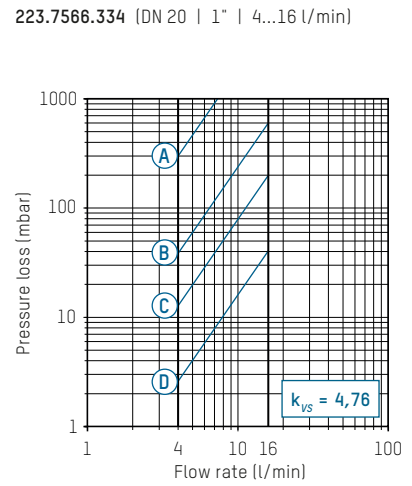
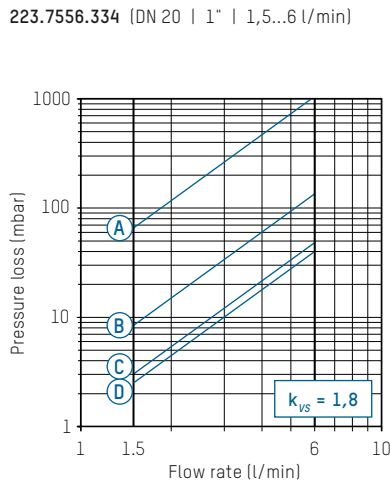
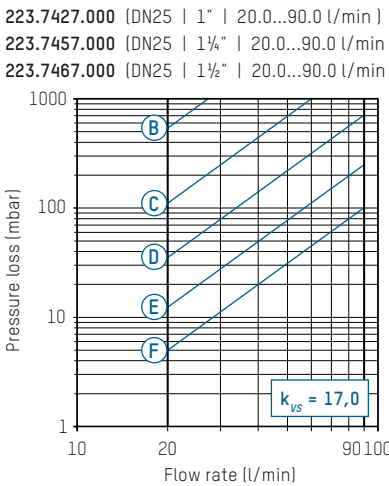
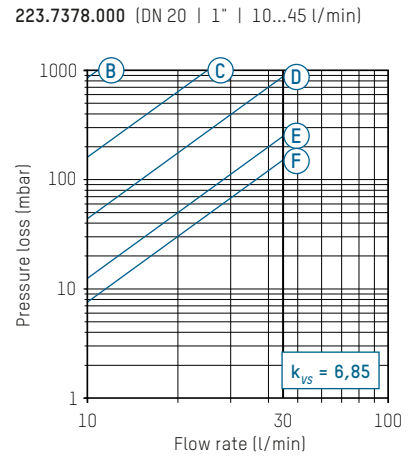
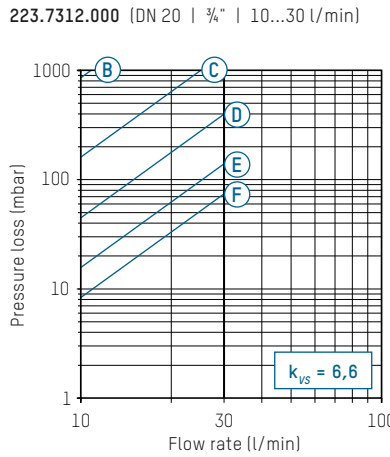
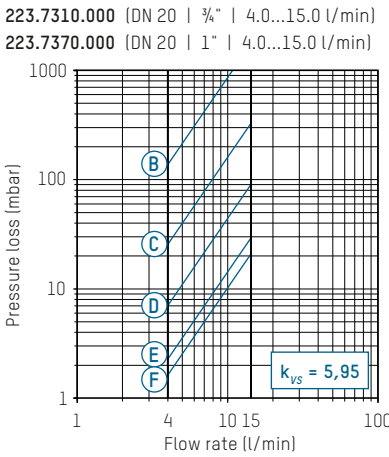
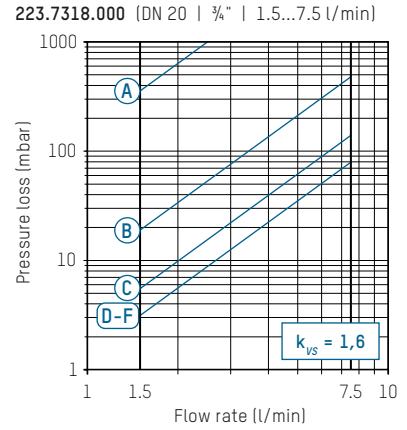
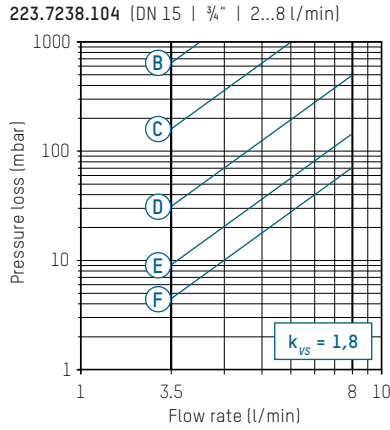
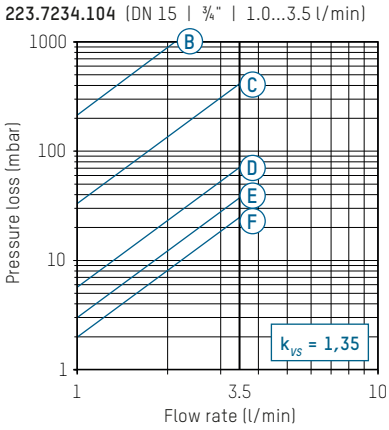

Ⓐ - Ⓕ Valve position

ACCESSORIES



CONNECTORS / ACCESSORIES

Order no.	Description
296.2334.000	Solar seal suitable 1" (glycol-resistant)

SYSTEM SCREW CONNECTION FITS TO TACOSSETTER INLINE

Comprising a cap nut, clamp ring and support sleeve

Order no.	G × mm	Version for	Fits to
210.3325.000	¾" × 15	Copper pipe 15/1 Eurocone	DN 15

Screw connections with cap nut and insert

Order no.	G × R	Version for	Fits to
210.6221.000	¾" × ½"	½" thread, conically sealing, dezincification-resistant	DN 15
210.6632.000	1" × ¾"	¾" thread, flat-sealing	DN 20
210.6632.121	1" × ¾"	¾" thread, flat-sealing (glycol-resistant seal)	DN 20
210.6633.000	1¼" × 1"	1" thread, flat-sealing	DN 20
210.3435.003	1" × d22	Cutting ring d22	DN 20
210.3434.003	1" × d18	Cutting ring d18	DN 20
210.6222.000	¾" × ½"	½" thread, self-sealing	DN 15

TACOSSETTER RONDO

BALANCING VALVE



Direct regulation and indication of flows to consumers.

DESCRIPTION

Direct hydraulic balancing and control of flows to consumers. Balancing valves offer a quick, easy and accurate method of adjusting the flow rates through heating, ventilating and air conditioning systems. Correct balancing of hydraulic circuits allows for lower flow temperatures, resulting in more efficient and economical operation in accordance with the energy saving regulations provided for by legislation. With TacoSetter Rondo balancing valves, any qualified fitter can set the appropriate water distribution, thus avoiding investments in training and costly measuring devices.

INSTALLATION POSITION

The balancing valve requires a straight section of pipe of the same length and diameter TacoSetter Rondo. The valve can be installed in a horizontal, vertical or inclined position. Care should be taken in order to ensure that the arrow is pointing in the direction of the flow.

OPERATION

The flow measurement is based on the displacement principle of a baffle disk, which is inserted in a measuring tube. The movement of the baffle disc is transformed to the sight glass by a mechanical device. The scale printed on the sight glass allows the flow rate to be read with ease.

ADVANTAGES

- Accurate and quick balancing without diagrams, tables or measuring devices
- The flow rate is displayed directly in l/min
- Variable installation position, maintenance-free, compact
- Regulating valve with isolating facility (rest leakage possible)
- Self-sealing screw connector
- Valve adjustment tool integrated in protective cover

Turning the sight glass changes the opening profile of the valve and allows the desired flow rate to be set.

BUILDING CATEGORIES

For pipe installations in heating and cooling area:

- Apartment blocks, housing estates, multiple dwelling units
- Residential care facilities and hospitals
- Administration and service buildings
- Hotels and restaurants, industrial kitchens
- School buildings and sports facilities
- Commercial and industrial buildings
- Facilities with partial use, such as barracks, camping sites

SYSTEM/BASIC DIAGRAM

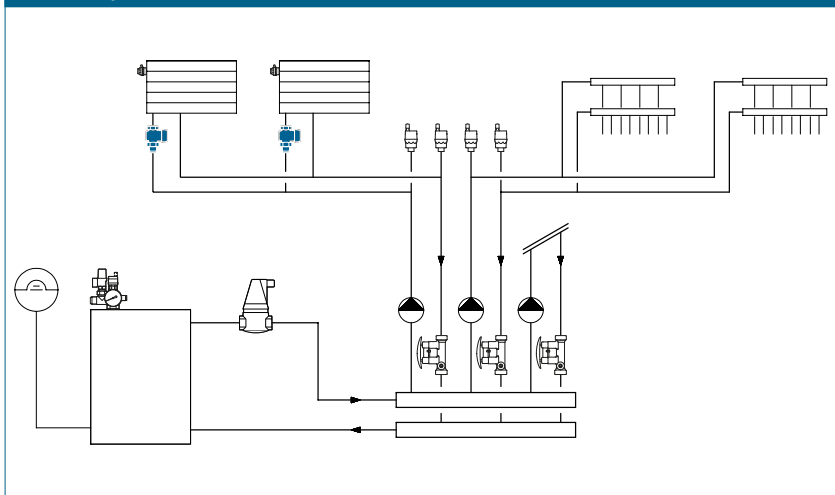

SPECIFICATION TEXT

See www.taconova.com

TECHNICAL DATA

General

- Admissible operating parameters
 $T_{0\max}$ und $P_{0\max}$: see pressure temperature curve
- Measuring accuracy:
 - <2l/min: = ±20% of the indicated value
 - >2l/min: = ±10% of the indicated value
- Female thread to DIN 2999 / ISO 7 or male thread G (cylindrical) to ISO 228

Material

- Housing: brass
- Inside: plastic
- Sight glass: heat- and impact-resistant plastic
- Sealing: EPDM

Fluids

- Heating water (VDI 2035; SWKI BT 102-01; ÖNORM H 5195-1)
- Water and proprietary additives used against corrosion and freezing up to 50%

TYPE OVERVIEW

TacoSetter Rondo | Balancing valve with screw connector

Order no.	DN	Thread	Measuring range	k_{VS} (m ³ /h)
223.3206.000 ①	15	Rp ½" × G ½"	0 – 8 (l/min)	1,0

TacoSetter Rondo | Balancing valve without screw connector

Order no.	DN	Thread	Measuring range	k_{VS} (m ³ /h)
223.3206.325 ①	15	Rp ½" × G ¾"	0 – 8 (l/min)	1,0
223.3206.341 ②	15	G ¾" × G ¾"	0 – 8 (l/min)	1,0

DIMENSIONAL DRAWING

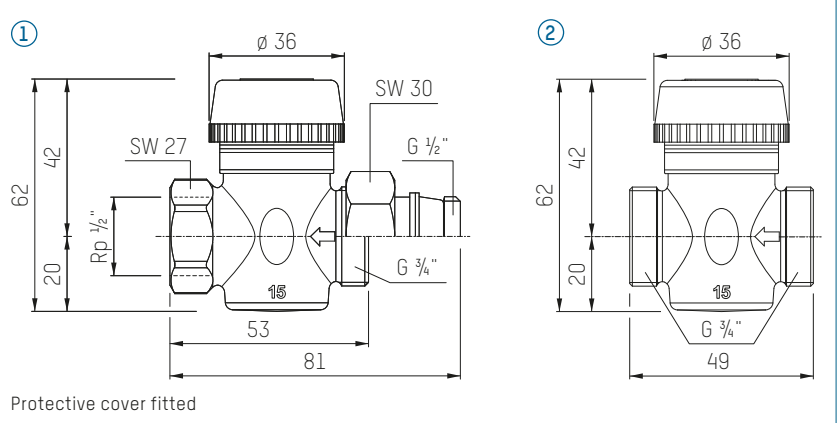

ACCESSORIES



SCREW CONNECTIONS FEMALE THREAD RP

Comprises a cap nut and insert

Order no.	DN	Thread	Version for
210.6221.000	15	G ¾" × R ½"	½" thread, conically sealing
210.6222.000	15	G ¾" × R ½"	½" thread, self-sealing

PRESSURE - TEMPERATURE CURVE

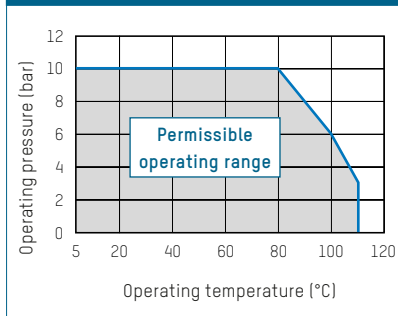

PRESSURE LOSS DIAGRAM

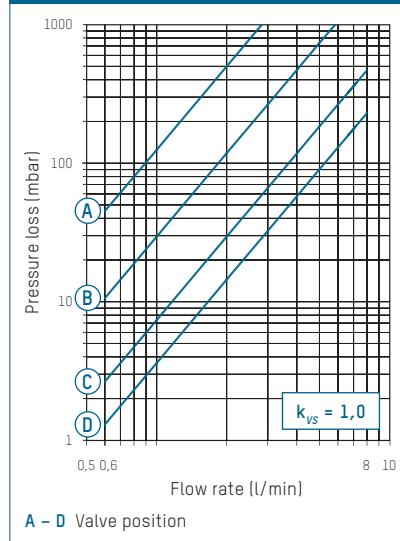

TACOSSETTER HYLINE

BALANCING VALVE

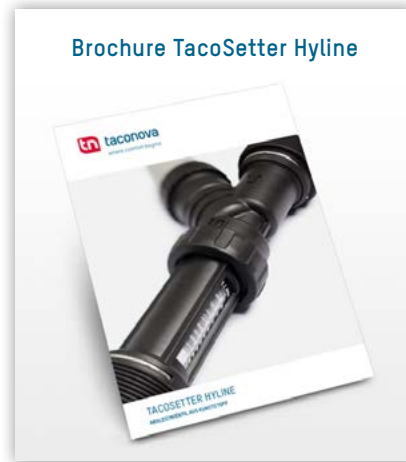

ADVANTAGES

- Valve made from high-quality, glass fiber-reinforced plastic, ideal for plastic systems
- Can be used for various media
- Inch standard thread: can be connected directly to plastic gland, no need for metal conversion adapters
- Fast, precise adjustment with twist grip
- High k_{VS} values
- Fast, simple assembly without tools

Direct adjustment, display and shutoff of flow in systems.

DESCRIPTION

Hydronic balancing and volume flow measurement: manufactured fully from high-quality plastic, TacoSetter Hyline balancing valves allow the required volume of water in geothermal, drinking water, heating, ventilating and air conditioning systems to be adjusted precisely and conveniently.

Correct balancing of hydraulic circuits ensures optimum energy distribution, resulting in more efficient and economical operation in accordance with the energy saving regulations provided for by legislation. The valves are quick and easy to fit and require no additional tools.

With TacoSetter Hyline balancing valves, specialists on site can adjust the required flow rate in l/min quickly and precisely using a scale, without the aid of diagrams, tables or investments in training and expensive measurement devices.

INSTALLATION POSITION

The balancing valve requires a straight flow section of the same length and nominal diameter as the valve used. The valve can be installed in a horizontal, tilted or vertical position. Only the arrow indicating the direction of flow of the medium needs to be noted. The valve must be installed free of stress.

OPERATION

The flow measurement is based on the principle of a baffle float integrated in the housing with return spring. The flow is adjusted manually using the twist grip on the angle seat valve. The reading position is the lower edge of the float element.

BUILDING CATEGORIES

For pipe installations in geothermal, drinking water and cooling installations:

- Apartment blocks, housing estates, multiple dwelling units
- Residential care facilities and hospitals
- Administration and service buildings
- Hotels and restaurants, industrial kitchens
- School buildings and sports halls / sports facilities
- Commercial and industrial buildings
- Facilities with partial use, such as barracks, camping sites

SYSTEM/BASIC DIAGRAM

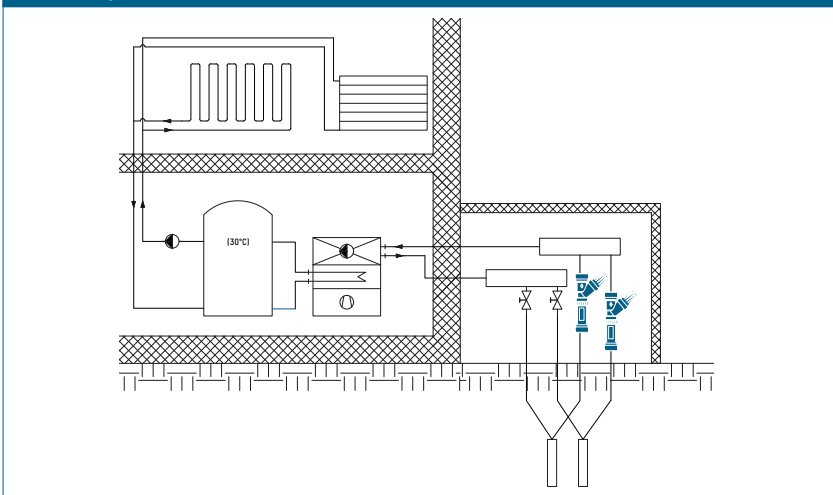

SPECIFICATION TEXT

See www.taconova.com

TECHNICAL DATA

General

- Maximum operating parameters
 $T_{0\ max}$ and $P_{0\ max}$: See pressure-temperature curve
- Measuring accuracy:
 $\pm 8\%$ of the final value
- k_{vs} value and measurement range according to „Type overview“ table
- External thread G (cylindrical) as per ISO 228
- Leakage test parameters:
 max. 12 bar / 20 °C / 1 hr

Material

- Housing: plastic, glass fiber-reinforced
- Spring + clamp: stainless steel
- Sight glass: borosilicate
- Seals: EPDM

Fluids

- Heating water (VDI 2035; SWKI BT 102-01; ÖNORM H 5195-1)
- Water and proprietary additives used against corrosion and freezing up to 50%
- Rainwater

NOTE

The valve must be installed free of stress.

TYPE OVERVIEW

TacoSetter Hyline | Balancing valve with external thread

Order no.	DN	G × G	Measuring range	k_{vs} (m ³ /h)
223.8410.000	25	1 ½" × 1 ½"	10 – 25 (l/min)	5.9
223.8411.000	25	1 ½" × 1 ½"	15 – 40 (l/min)	9.1
223.8412.000	25	1 ½" × 1 ½"	20 – 60 (l/min)	11.7
223.8523.000	32	2" × 2"	20 – 55 (l/min)	11.7
223.8524.000	32	2" × 2"	30 – 80 (l/min)	12.5

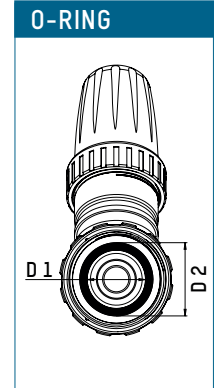
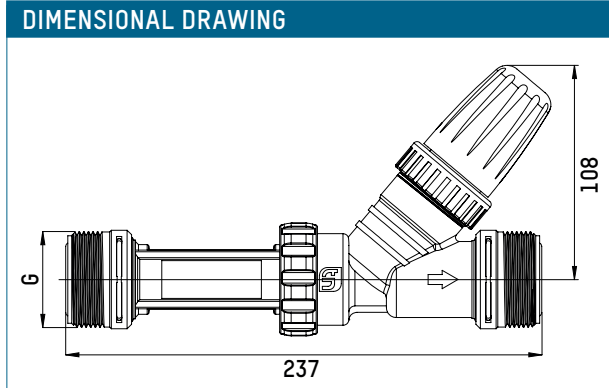

MEASUREMENT TABLE

TacoSetter Hyline | Balancing valve with external thread

Order no.	DN	G	D1	D2	O-Ring
223.8410.000	25	1 ½"	29.7	36.4	29.82 × 2.62
223.8411.000	25	1 ½"	29.7	36.4	29.82 × 2.62
223.8412.000	25	1 ½"	29.7	36.4	29.82 × 2.62
223.8523.000	32	2"	36.0	42.7	36.10 × 3.53
223.8524.000	32	2"	36.0	42.7	36.10 × 3.53

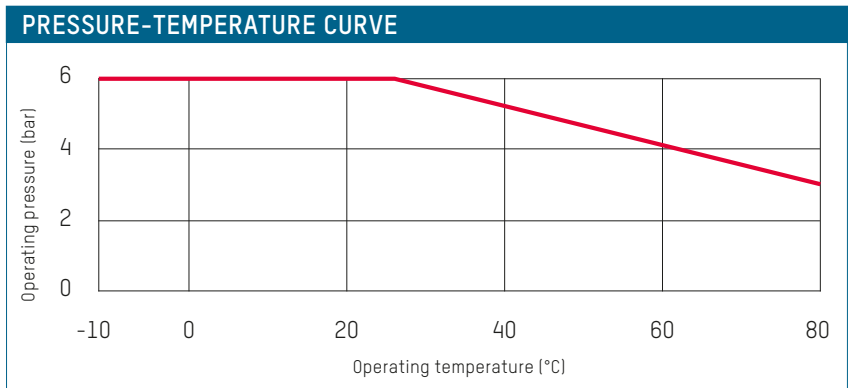

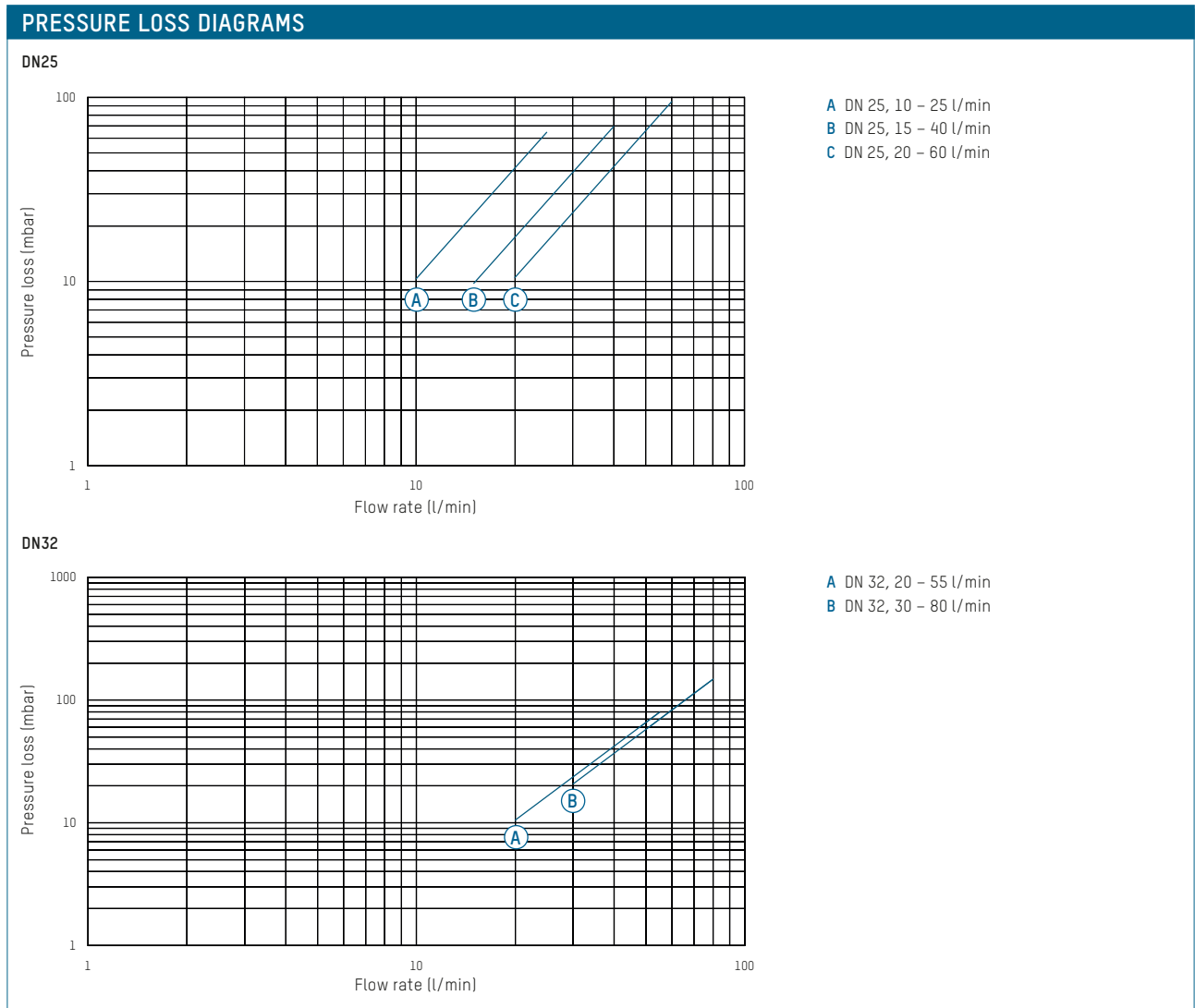

ACCESSORIES



SCREW CONNECTOR FOR TACOSSETTER HYLINE

Plastic screw connector with washer (PVC) and weld-on socket (PE100)

Order no.	G (washer)	Fits to
210.2025.003	1½"	DN 25
210.2032.003	2"	DN 32

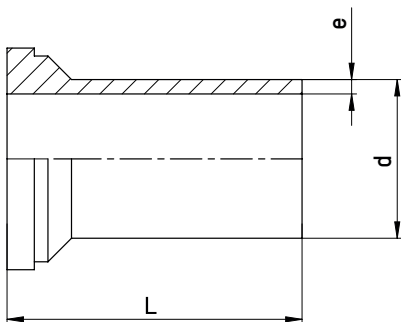

	d	L	e
DN25	32	60	2.9
DN32	40	63	3.7

TACOSSETTER TRONIC

BALANCING VALVE



W270

ADVANTAGES

- Precise and fast electronic measurement of flow volume and temperature
- High measurement precision
- Measurement range 0...100 °C
- Temperature measurement directly in the medium
- Direct connection to circulating pump, variable installation position
- Glycol resistant
- Regulating valve with isolating facility (rest leakage possible)

Electronic flow volume and temperature measurement

DESCRIPTION

Flow volumes and temperatures can be very easily measured and simultaneously evaluated with the TacoSetter Tronic.

The features of the TacoSetter Tronic include its different options for use in drinking water, solar and heating systems.

The electrical signals for flow and temperature can be used for the control and monitoring of pumps and valves, or for heat quantity metering. A controller, from Sorel for example, can be used to display the measurement data.

The control valve can limit or interrupt the flow.

Hydraulically correct balanced systems ensure optimum energy distribution and in this way maintain economic operation as required by the Energy Saving Regulations.

INSTALLATION POSITION

The valve can be installed in a horizontal, tilted or vertical position.

Only the direction of the arrow indicating the flow of the medium needs to be noted.

For horizontal installation, it is recommendable to position the sensor on the upper side in order to prevent deposits occurring.

OPERATION

The TacoSetter Tronic was developed for the combined measurement of flow volume and temperature. The flow measurement is based on the vortex principle.

The vortex shredding on the body in the flow is proportional to the flow rate.

The generated vortices are detected by a piezoelectric sensor and evaluated by the integrated electronics.

BUILDING CATEGORIES

For pipe installations in drinking water, heating and cooling area:

- Apartment blocks, housing estates, multiple dwelling units
- Residential care facilities, hospitals
- Administration and service buildings
- Hotels and restaurants, industrial kitchens
- School buildings and sports facilities
- Commercial and industrial buildings
- Facilities with partial use, such as barracks, camping sites

SYSTEM/BASIC DIAGRAM

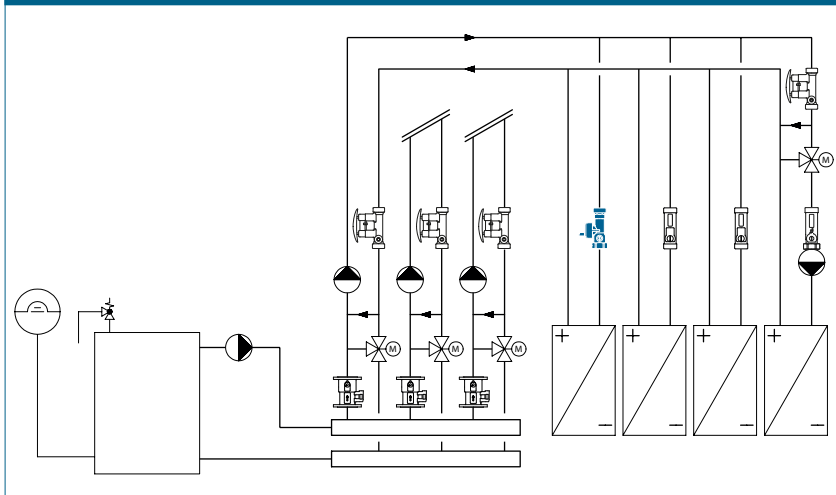

SPECIFICATION TEXT

See www.taconova.com

TECHNICAL DATA

General

- Operating temperature $T_{0\max}$: 120 °C
- Operating pressure $P_{0\max}$: 10 bar
- Measurement temperature range: 0...100 °C
- Measurement precision and range:
 - 1–12 l/min: <3 % of final value
 - 2–40 l/min: 1,5 % of final value
- Viscosity of medium see «Type overview»
- Thread G (cylindrical) as per ISO 228
- 1" flat-sealed connections
- Protective class: IP44a

Material

- Housing: brass
- Internal parts: brass, stainless steel, plastic
- Sensor: PPS, PPA, PA
- Seals: EPDM

Fluids

- Heating water (VDI 2035; SWKI BT 102-01; ÖNORM H 5195-1)
- Potable water (DIN 1988-200)
- Water and proprietary additives used against corrosion and freezing up to 50%

Electrical signals for sensors

- Temperature: 0.5 to 3.5 V
- Flow: 0.5 to 3.5 V
- Ground: 0 V (PE)
- Supply voltage (+5VDC), PELV

APPROVALS / CERTIFICATES

Sensor

- KTW, W270, ACS, NSF, WRAS

Housing parts

- KTW, W270

TYPE OVERVIEW

TacoSetter Tronic 100 | Balancing and shut-off valve with electronic measurement function

Order no.	DN	G × G	Measuring range	Viscosity
223.7702.000	20	1" × 1" A	1 – 12 (l/min)	≤ 4 mm ² /s
223.7704.000	20	1" × 1" A	2 – 40 (l/min)	≤ 2 mm ² /s

DIMENSIONAL DRAWING

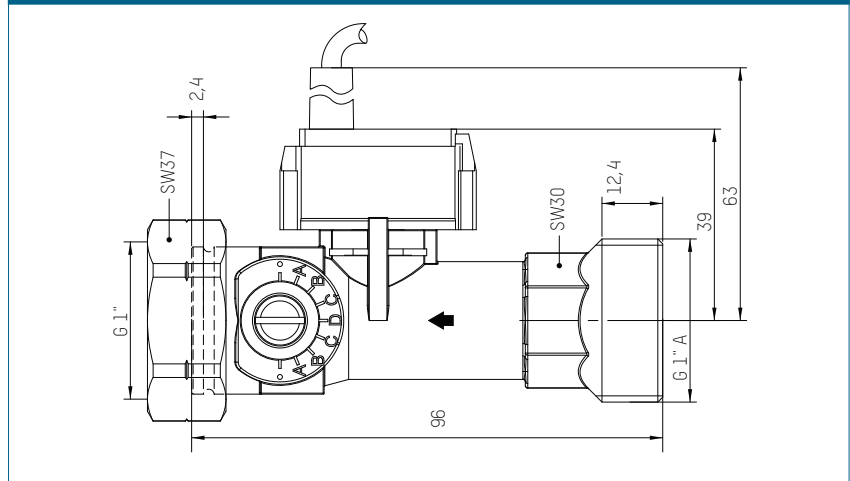

PRESSURE LOSS DIAGRAMS

223.7702.000 (DN 20 | 1" | 1...12 l/min)

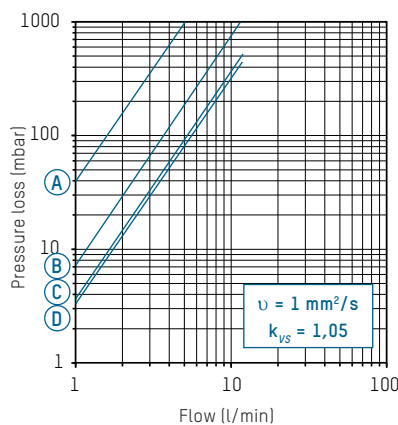

A – D Valve position

223.7704.000 (DN 20 | 1" | 2...40 l/min)

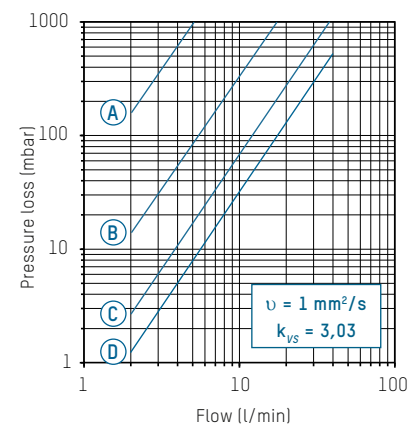

A – D Valve position

ACCESSORIES



CONNECTIONS

Order no.	Description
210.6632.121	flat-sealed screw joint with R 3/4" Male threads (glycol-resistant seal)
296.2334.000	Solar seal 1" (glycol-resistant)

REMOTE SENSOR PT1000 (FOR HEAT QUANTITY METERING)

Order no.	Length	Version
296.7015.000	0.5 m	Including pipe clamp

GLYCOL CORRECTION CURVES

For use of anti-frost and anti-corrosion agents with TacoSetter balancing valves

KINEMATIC VISCOSITY OF ANTIFROGEN L

Figure 1 - Water mixtures of different concentrations

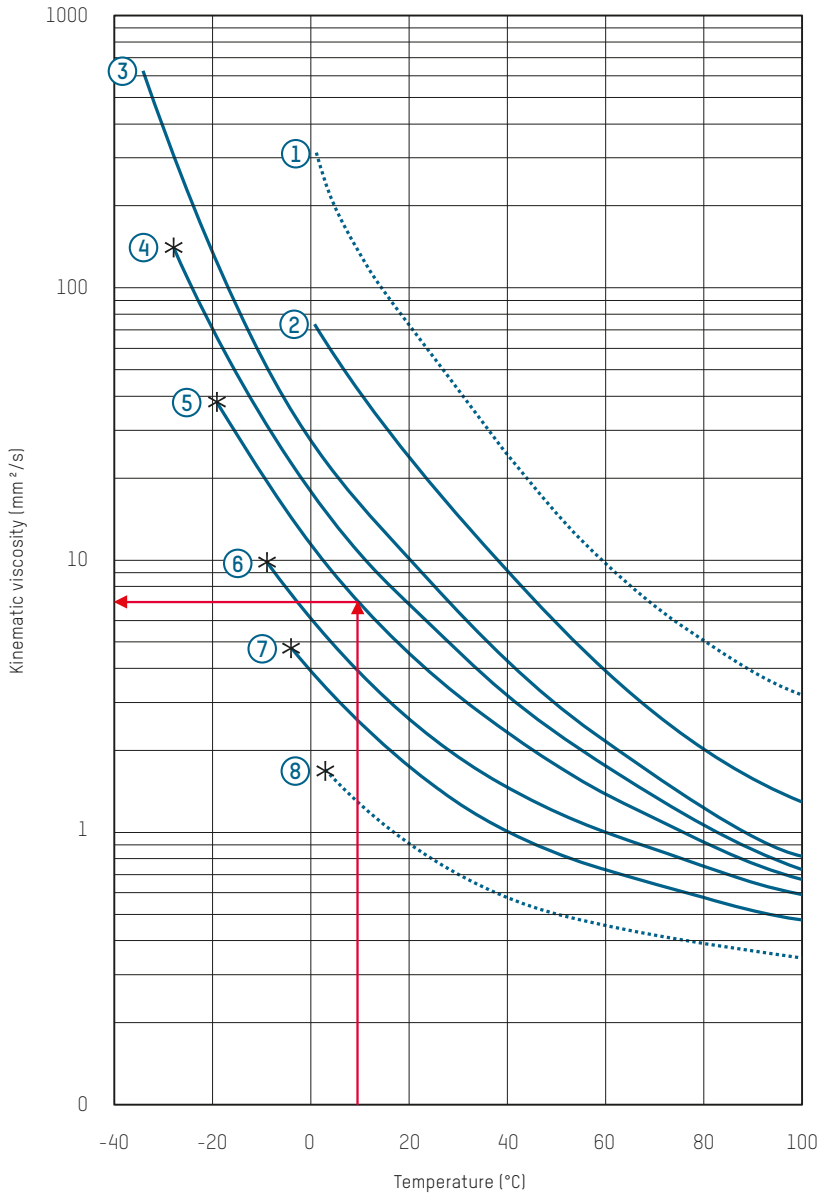

Curve no.	Concentration
1	100% v/v = Antifrogen L
2	80% v/v
3	57% v/v
4	47% v/v
5	38% v/v
6	25% v/v
7	16% v/v
8	Water

* = Frostproofness

INSTRUCTIONS FOR USE OF THE CORRECTION CURVES

Anti-icers and corrosion inhibitors are inhibitors based on propylene glycol which are mixed with water. This prevents undesirable reactions such as corrosion or the freezing of hydraulic systems.

These mixtures give rise to other physical material values than those occurring in the case of pure water. These material values depend on the one hand on the mixture ratio in %, and on the other on the temperature of the mixture.

The mixture ratio depends on the desired properties, for example frostproofness.

FLOW

As a result of the changed material values, the flow indicated on the TacoSetter varies. The reason for this is the higher viscosity and density of the water mixture compared with pure water.

The **kinematic viscosity** of the water mixture is the critical factor in determining the correction value. This value is derived from diagrams and product documentation published by the manufacturers of inhibitors. The diagram set out in Fig. 1, which was provided by Messrs. Clariant, is the basis for the specimen calculation with Antifrogen L.

Fig. 1 Source: Clariant GmbH, Divisions Chemicals, D-65840 Sulzbach

GLYCOL CORRECTION CURVES

CORRECTION CURVES

A separate diagram with nine correction curves exists for TacoSetter up to DN25 and its flow ranges.

These correction curves cover a kinematic viscosity range from 1 mm²/s to 53 mm²/s.

These curves are assigned to the kinematic viscosity read from Figure 1 in the adjacent table.

KINEMATIC VISCOSITY OF THE CORRECTION CURVES

Correction curve no.	Kinematic viscosity
1	53,0 mm ² /s
2	30,0 mm ² /s
3	17,0 mm ² /s
4	6,7 mm ² /s
5	4,7 mm ² /s
6	3,5 mm ² /s
7	2,2 mm ² /s
8	1,7 mm ² /s
9	1,0 mm ² /s

SPECIMEN CALCULATION

Given

- Antifrogen L concentration: 38%
-> Figure 1: Curve 5
- Mix temperature: 10 °C
- Indicated flow: 3,5 l/min

Sought

- Effective flow in l/min when using a TacoSetter Inline 100 (Art.: 223.1204.000)

Solution

- On the basis of the manufacturer's diagram Fig 1, a kinematic viscosity of **7 mm²/s** is arrived at
- According to table Fig. 2, **6.7 mm²/s** indicates **correction curve No. 4**
- An **effective flow of 2.6 l/min** can be determined from the indicated 3.5 l/min, using the diagram for this TacoSetter Inline 100 and **curve No. 4**

Conclusion

- Given an Antifrogen L concentration of 38% and a mix temperature of 10 °C, the effective flow diverges from the indicated flow by -26%.

CORRECTION CURVES TACOSSETTER INLINE 100

DN15

223.1202.XXX (0,3...1,5 l/min)
223.1203.XXX | 223.1233.XXX (0,6...2,4 l/min)

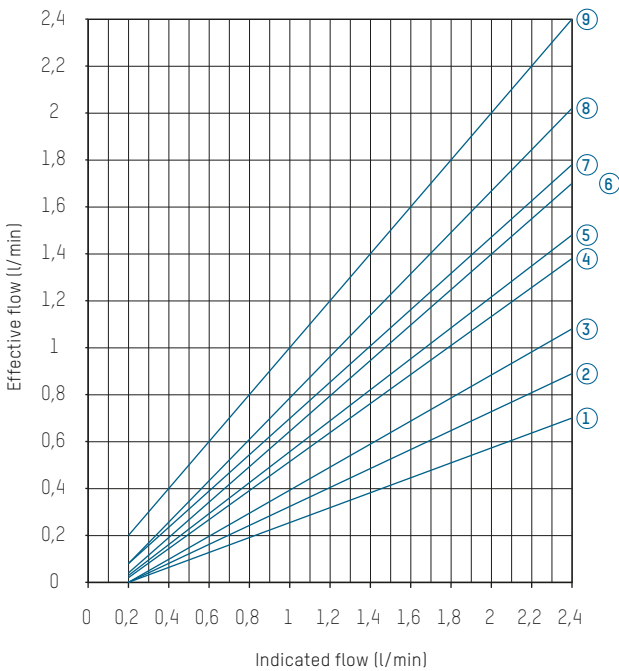

DN15

223.1204.XXX (1,0...3,5 l/min)
223.1234.XXX (1,0...3,5 l/min)

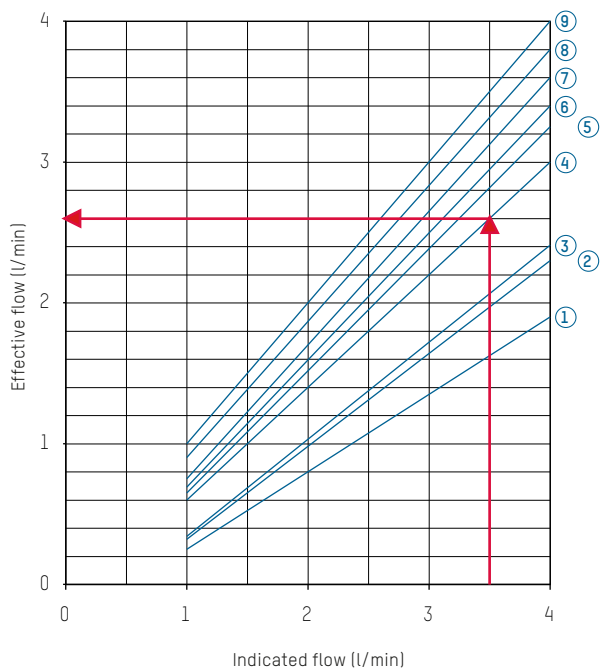

CORRECTION CURVES TACOSSETTER INLINE 100

DN15

223.1238.XXX | 223.1208.XXX (2...8 l/min)
 223.1239.XXX | 223.1209.XXX (3...12 l/min)

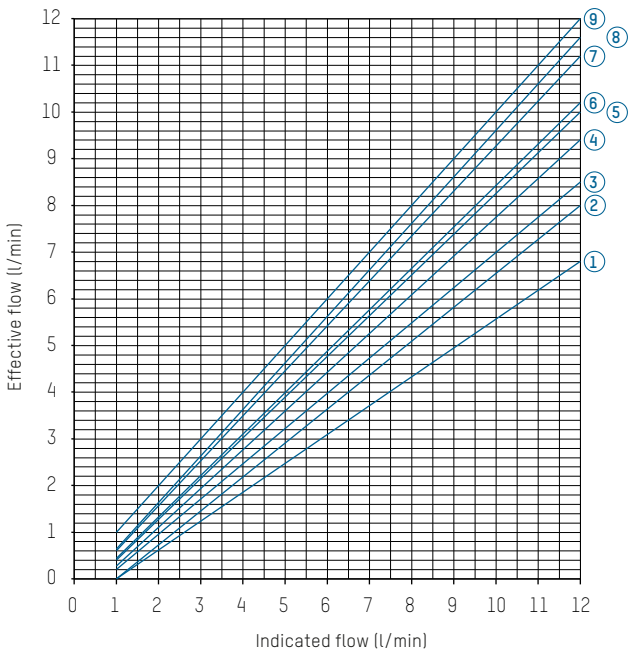

DN20

223.1300.XXX (4...15 l/min)

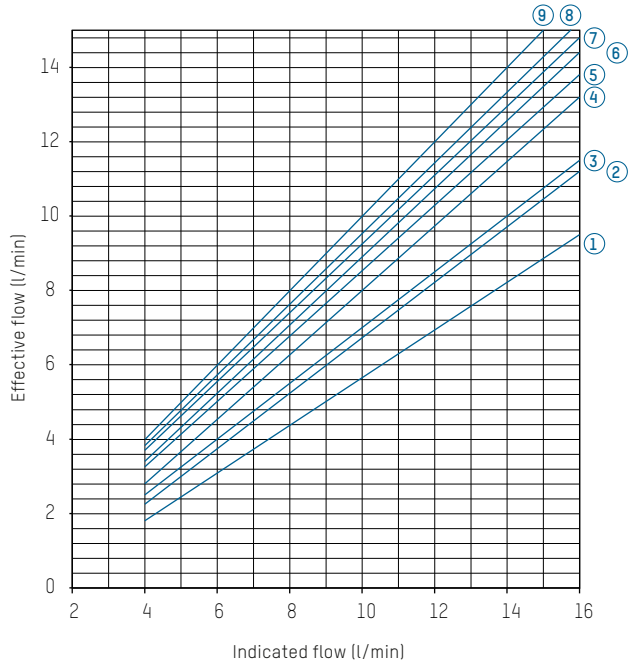

DN20

223.1302.XXX (8...30 l/min)

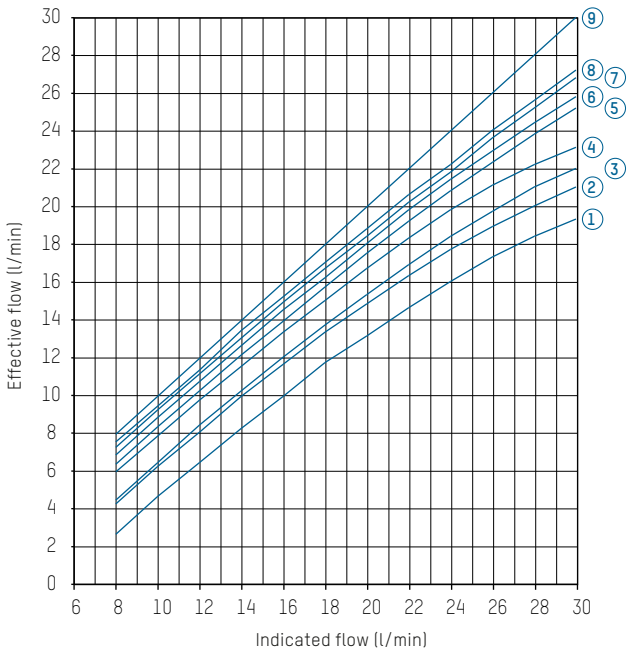

DN20

223.1305.XXX (10...40 l/min)

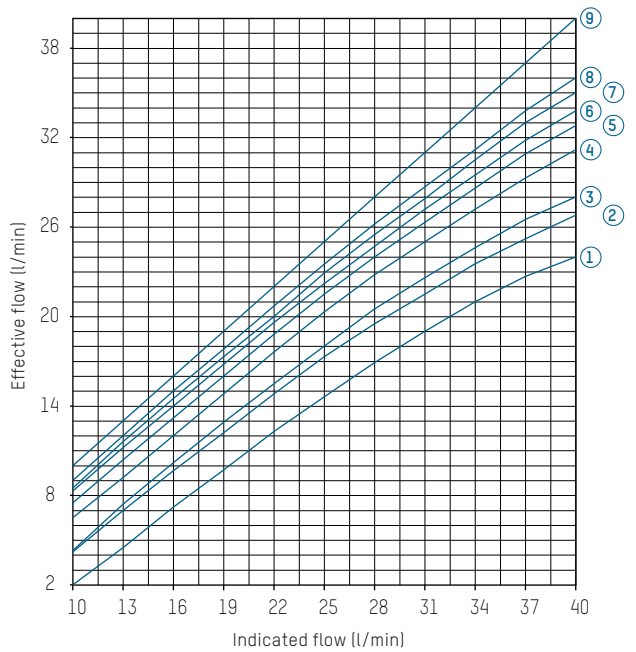

CORRECTION CURVES TACOSSETTER BYPASS 100 | TACOSSETTER BYPASS SOLAR 130 | TACOSSETTER BYPASS SOLAR 185

DN15/DN20

223.2262.XXX | 223.2361.XXX | 223.2272.XXX (2...8 l/min)
 223.2360.XXX | 223.2370.XXX (4...15 l/min)
 223.2380.XXX | 223.2382.XXX (2...12 l/min)

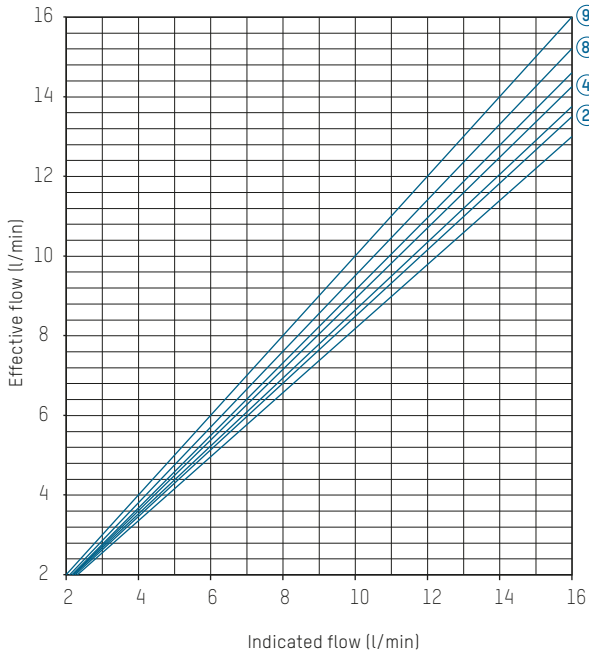

DN20

223.2362.XXX | 223.2372.XXX (8...30 l/min)
 223.2381.XXX | 223.2383.XXX (8...20 l/min)

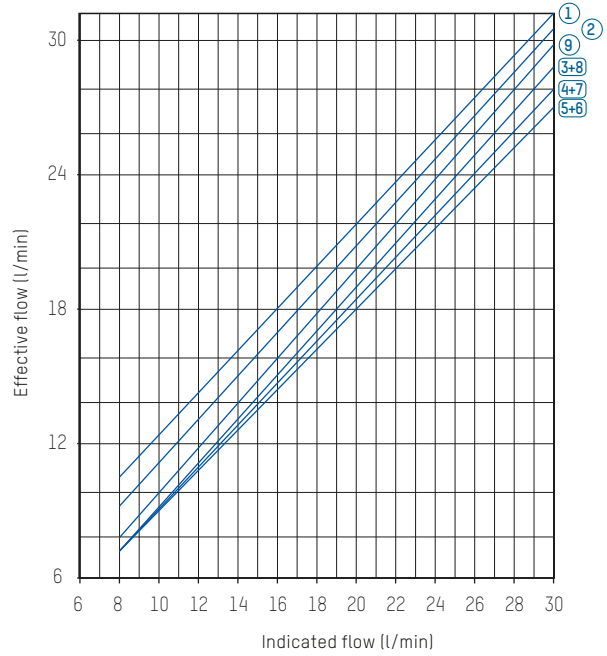

DN25

223.2460.XXX | 223.2470.XXX (6...20 l/min)

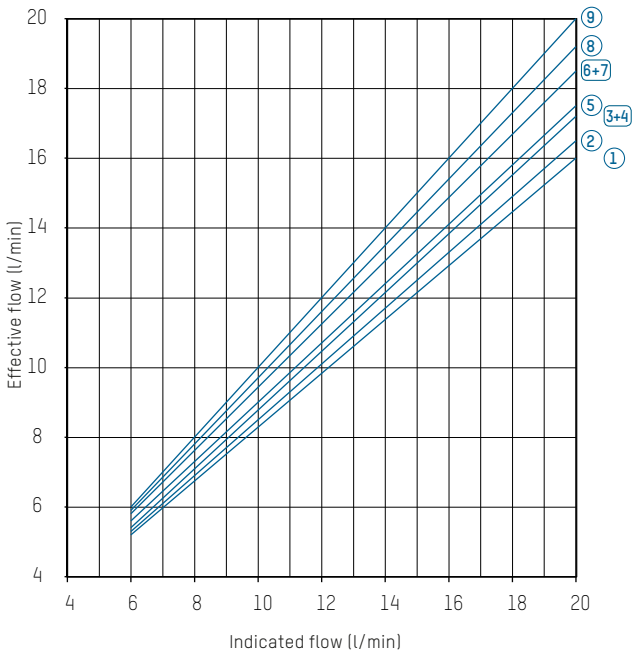

DN25

223.2461.XXX | 223.2471.XXX | 223.2480.XXX (10...40 l/min)
 223.2482.XXX (10...40 l/min)

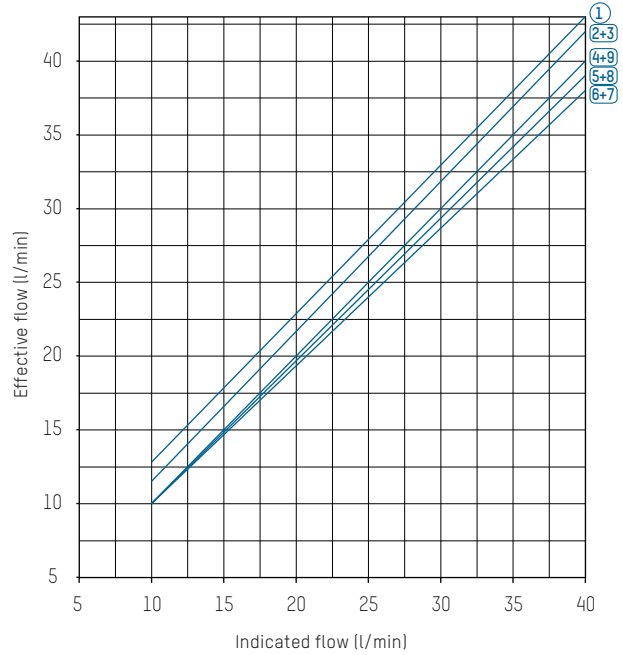

CORRECTION CURVES TACOSSETTER HYLINE

DN25

223.8410.000 (10...25 l/min)

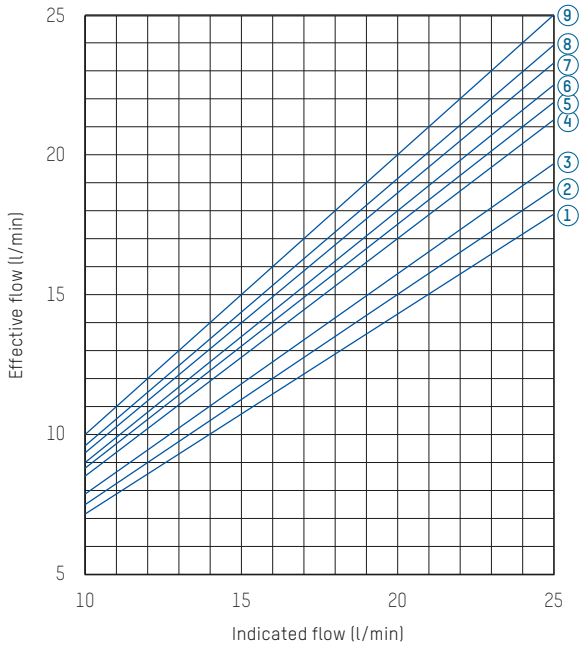

DN25

223.8411.000 (15...40 l/min)

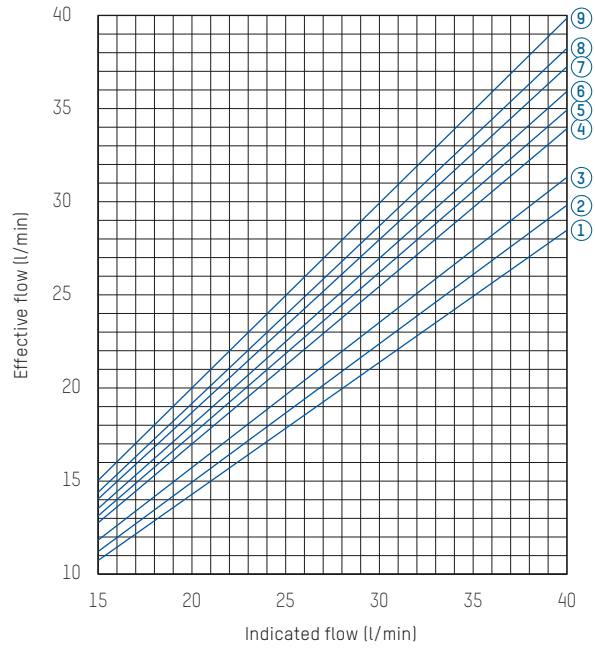

DN25/DN32

223.8412.000 (20...60 l/min)

223.8523.000 (20...55 l/min)

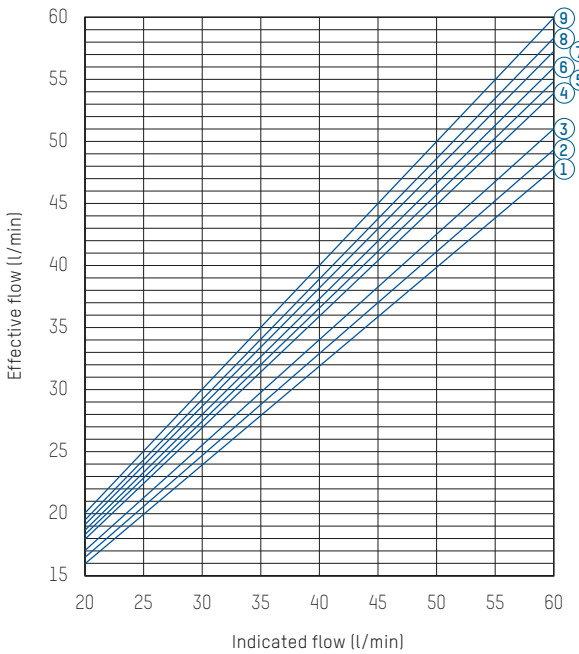

DN32

223.8524.000 (30...80 l/min)

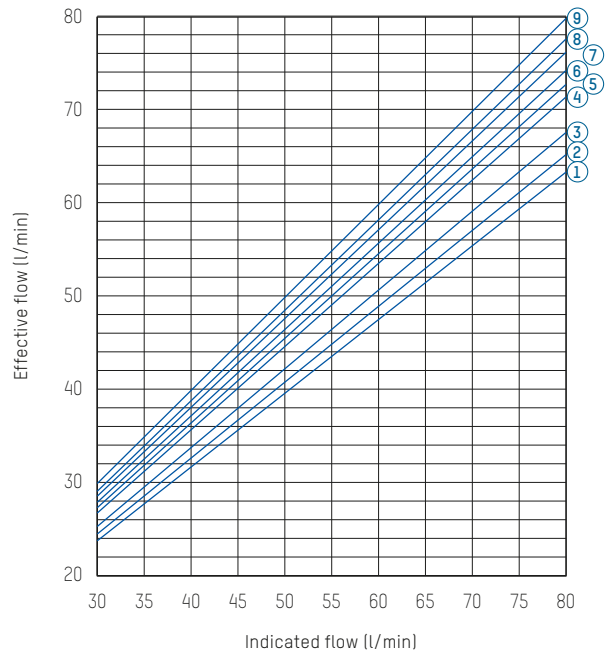

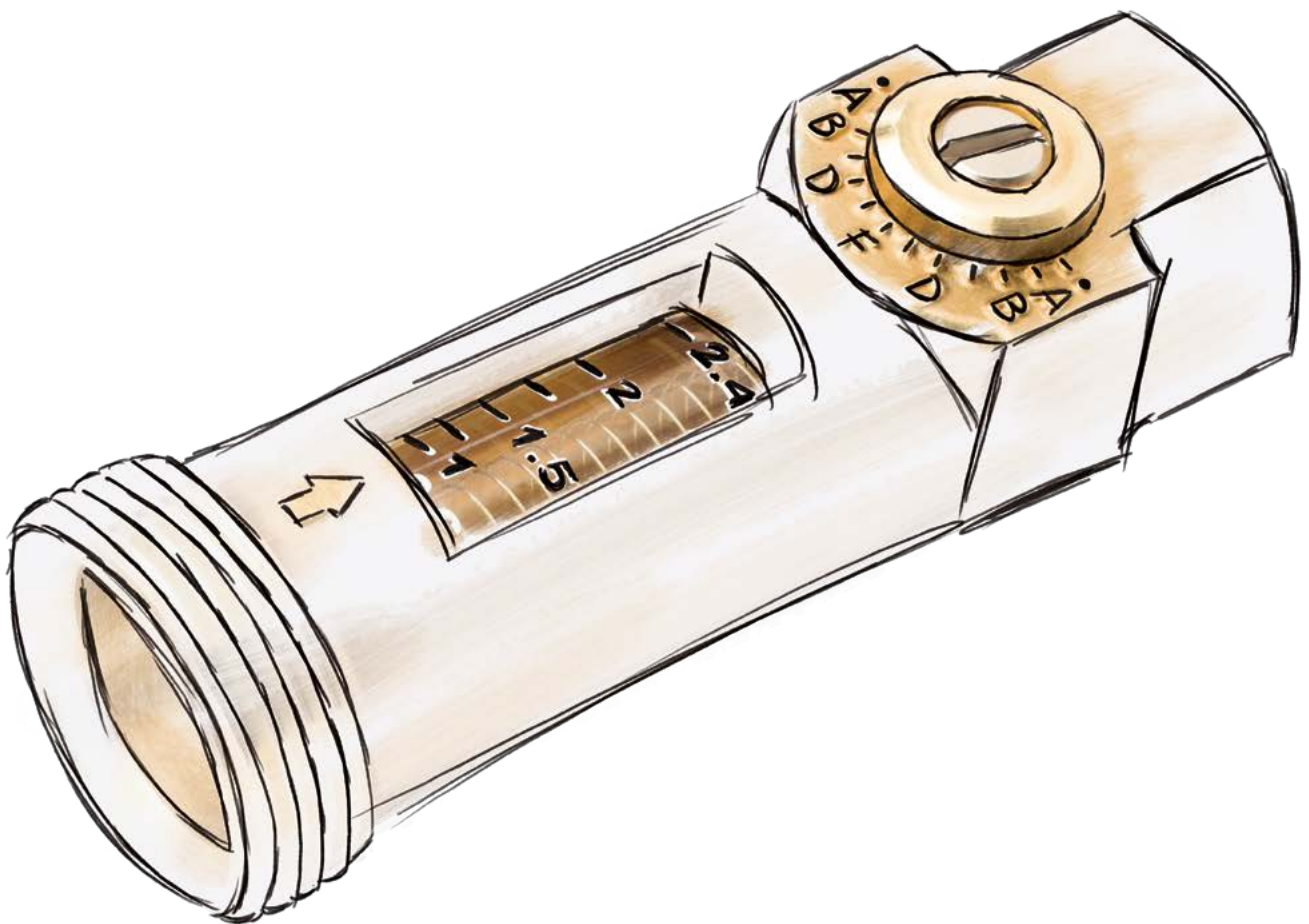

FLOW CONTROL IN ANY INSTALLATION POSITION

A display is often required to enable flow values to be checked in hydraulic systems, without a regulating option also being necessary at the same time.

FLOW CONTROL IN ANY INSTALLATION POSITION

The TacoControl FlowMeter flow measuring instrument shows the volume flow of the flowing medium and is used in heating, cooling and plumbing systems to check the flow rate.

The meter's compact design allows it to be installed in even the most constricted spaces. Any installation position is possible – all that really matters is the direction of flow.

DIRECT DISPLAY

The calibrated scale printed on the inspection window enables the flow rate to be read directly in l/min without requiring complex meters and counters directly on the consumer, on distributors or in sections of systems.

FUNCTION IRRESPECTIVE OF THE INSTALLATION POSITION

The TacoControl FlowMeter flow measuring instrument is based on the TacoSetter Inline balancing valve. A 1" union nut is used to connect the valve body, nominal size DN 20, directly to a flush sealing screw connector, for example to the intake connectors of a pump housing, in any installation position.

EXPANDABLE TO FORM A BALANCING VALVE

In combination with the TacoSetter Inline balancing valve, the function of both flow meters can be extended to produce a regulating and shutoff valve

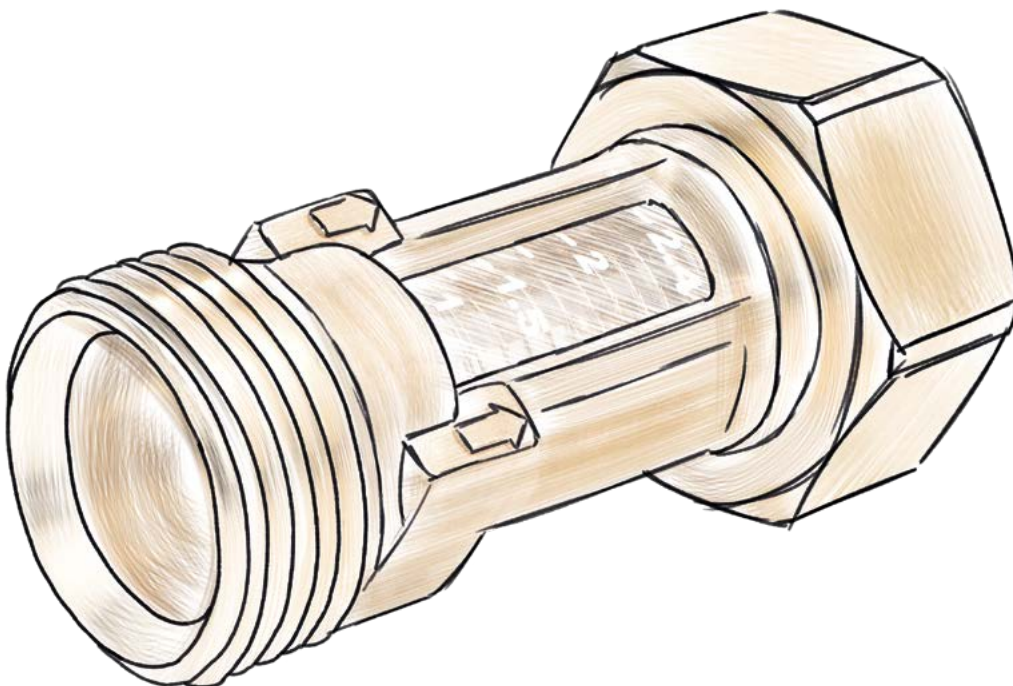

FUNCTION MONITORING IN HYDRAULIC SYSTEMS

Flow rates can be recorded in hydraulic systems using measuring valves.

BENEFITS AT THE PLANNING STAGE

- High measurement precision
- Short response time

BENEFITS AT THE INSTALLATION STAGE

- Can be installed in any position
- Can be combined with TacoSetter Inline balancing valve
- Can be installed in heating, cooling, solar and drinking water systems, including heat measurement

Flow meter	
Volume flows are measured and indicated purely mechanically.	▪ TacoControl FlowMeter

APPLICATIONS

Valves and accessories from Taconova can be used in various ways in heating, air conditioning, ventilation and sanitary systems:

Heating and cooling energy generation	Heating and cooling energy distribution (Indoor temperature control)	Sanitary systems
<ul style="list-style-type: none"> ▪ Solar thermal energy ▪ Oil, gas, electricity, biomass ▪ District heating 	<ul style="list-style-type: none"> ▪ Underfloor heating ▪ Radiators ▪ Chilled and heated ceilings 	<ul style="list-style-type: none"> ▪ Fresh water

TACOCONTROL FLOWMETER

FLOW INDICATOR



ADVANTAGES

- The flow rate is displayed directly in l/min
- Accurate and quick indication of flow rates without additional measuring devices
- Low pressure loss
- Eurocone bore hole
- Can be installed in any position
- Compact design

Direct indications of flows in hydraulic systems.

DESCRIPTION

The FlowMeter offers an accurate and convenient indication of flow rates in heating -, ventilation -, air conditioning- and cooling systems. Due to the compact design of the FlowMeter, the installation of a flow rate indicator is possible, even at most limited space.

The particular connection is suitable for a direct and economic fit to components with eurocone adaptors. Installed on heating manifolds or on a valve, the FlowMeter forms an economical extension of the function with big benefits.

For example, each throttle valve in addition with a FlowMeter turns into a multi function valve for the balan-

cing and the indication of flow rates. With the FlowMeter, any qualified fitter can read the appropriate flow rate easily on site, without any additional measuring device or special training

INSTALLATION POSITION

The valve can be installed in a horizontal, vertical or inclined position. Care should be taken in order to ensure that the arrow is pointing in the direction of the flow
Noise can be avoided by installing a short calming section in front of the flow meter.

OPERATION

The flow measurement is based on the principle of a baffle float with countersprings.

The flow rate is displayed on a calibrated scale by an integrated flowmeter.

The reading position is the bottom line of the baffle float.

BUILDING CATEGORIES

For pipe installations in heating and cooling area:

- Apartment blocks, housing estates, multiple dwelling units
- Residential care facilities and hospitals
- Administration and service buildings
- Hotels and restaurants, industrial kitchens
- School buildings and sports facilities
- Commercial and industrial buildings

SYSTEM/BASIC DIAGRAM

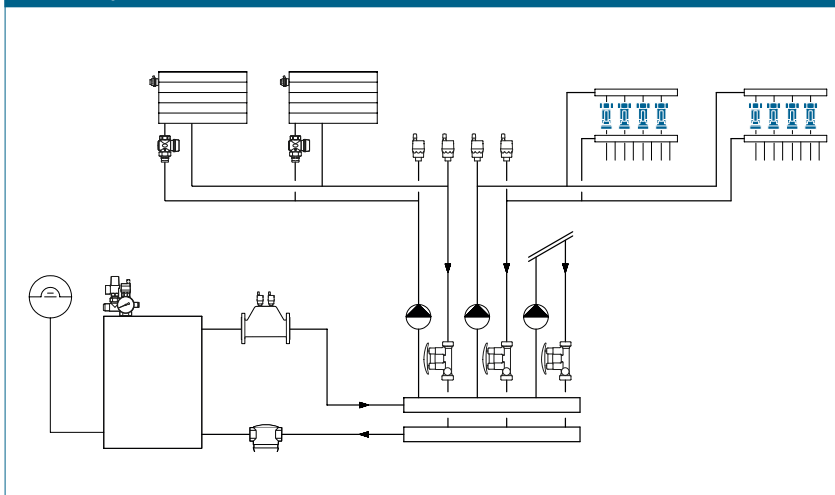

SPECIFICATION TEXT

See www.taconova.com

TECHNICAL DATA

General

- Operating temperature $T_{0\text{ max}}$: 100 °C
- Operating pressure $P_{0\text{ max}}$: 10 bar
- Measuring accuracy: ±10 % of the indicated value
- k_{VS} value and measurement range see «Type overview»
- Thread G (cylindrical) to ISO 228
- With 18 mm hole for Taconova and all Eurokonus screw

Material

- Housing: brass
- Inside: stainless steel, brass, plastic
- Sight glass: heat- and impact resistant plastic
- Seals: EPDM

Fluids

- Heating water (VDI 2035; SWKI BT 102-01; ÖNORM H 5195-1)
- Potable water (DIN 1988-200)
- Water and proprietary additives used against corrosion and freezing up to 50%

APPROVALS / CERTIFICATES

- Housing parts: KTW, W270, ACS

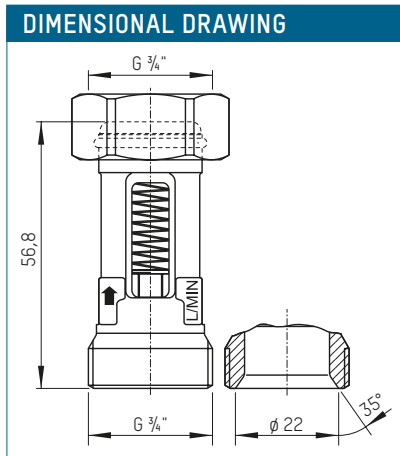

TYPE OVERVIEW

TacoControl FlowMeter | Flow meter with direct indication

Order no.	DN	G×G	Measuring range	k_{VS} (m³/h)
223.4213.000	15	¾" × ¾"	0,6 – 2,4 (l/min)	0.5
223.4214.000	15	¾" × ¾"	1,0 – 3,5 (l/min)	1.1
223.4218.000	15	¾" × ¾"	2,0 – 8,0 (l/min)	1.6
223.4219.000	15	¾" × ¾"	3,0 – 12,0 (l/min)	1.65

PRESSURE LOSS DIAGRAMS

223.4213.000 (DN 15 | ¾" | 0,6...2,4 l/min)

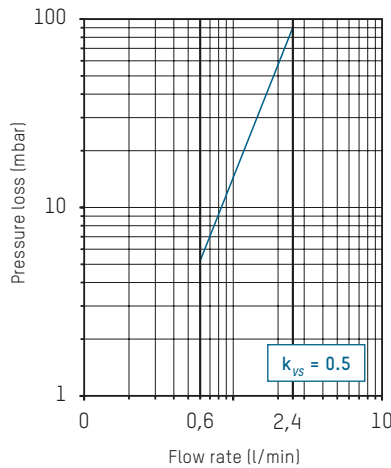

223.4214.000 (DN 15 | ¾" | 1,0...3,5 l/min)

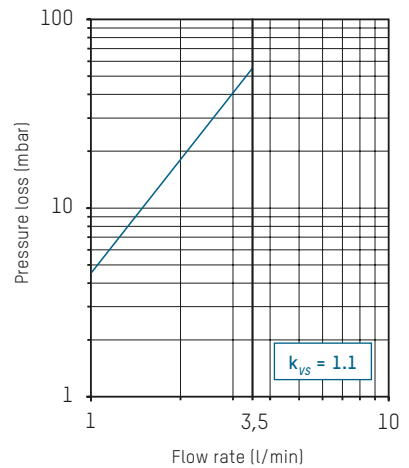

223.4218.000 (DN 15 | ¾" | 2,0...8,0 l/min)

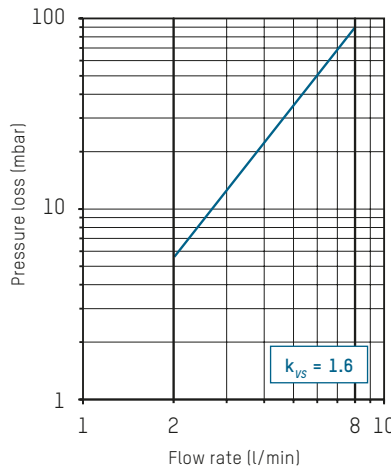

223.4219.000 (DN 15 | ¾" | 3,0...12,0 l/min)

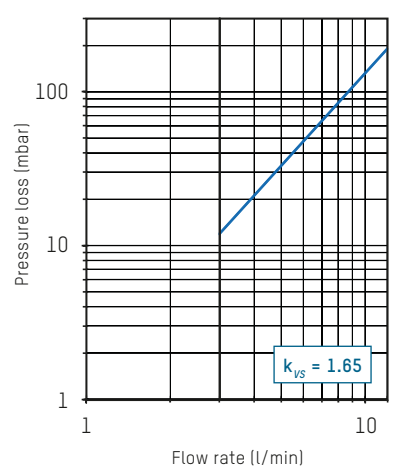

AREA HEATING SYSTEMS

The targeted heating of individual rooms increases the comfort level, reduces energy consumption and allows economical operation of the heating system. For this purpose, optimum energy distribution is essential: At the main manifold in the cellar or service room, the main volume flows are hydraulically balanced and distributed to the different parts of the building.

To ensure the preferred room and heating circuit temperatures, fine distribution is additionally required on each floor, in the form of intelligent and reliable area heating distributors.

This takes place, in part, by further hydraulic balancing directly on the manifold bar and, in part, through accurate electronic valve control according to the OPEN/CLOSE principle using room thermostats. The controlled opening and closing of these valves varies according to the heat requirements.

Taconova's comprehensive range is characterised by products that are optimally matched to each other and can be combined in a variety of ways.

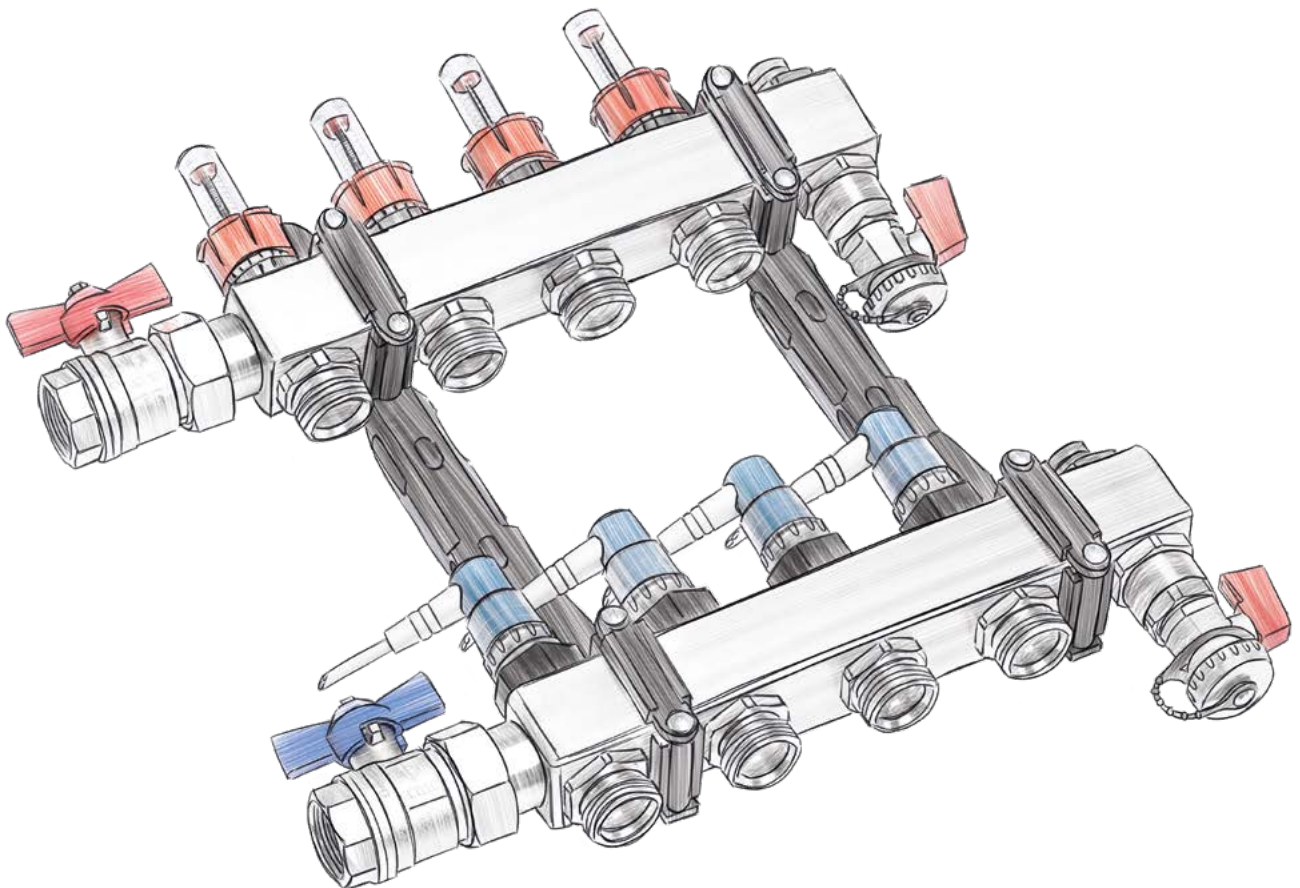

PERFECT INTERACTION

Taconova can demonstrate proven expertise in area heating systems. Innovative technology and first class components ensure a reliable, cost-saving energy supply where it is needed. Matching underfloor heating systems, balance valves, actuators, room thermostats and connecting modules work together to create the optimum room climate for individual requirements.

The selection of high quality products covers all requirements in the field of heating and cooling distribution.

OVERVIEW OF PRODUCT GROUPS



THE MANIFOLD

Robust stainless steel manifold bars fitted with innovative technology ensure reliable and economical supply of energy where it is needed. In the TacoSys High End version, the well-known TopMeter ensures perfect hydraulic balancing. The latest TacoDrive actuator is already preinstalled in the TacoSys Pro version and can be combined with ease with the NovaStat room thermostats.



THE FIRST CHOICE

The TopMeter is the first choice for the regulation of manifold systems. The flow rate through heating and cooling energy circuits can be regulated, indicated and shut off directly on the supply or return bar. The last hydraulic balancing setting can be reproduced with the latest version of the balancing valve, the TopMeter Plus.



THE GATEKEEPER

Actuators are the reliable gatekeepers which open or close the valves of the individual heating circuits according to the heat requirement. They take care of the fine adjustment, are silent in operation and require no maintenance. Together with NovaStat room thermostats, they create a climate adjusted for each room. TacoDrive actuators have a drive integrated in the valve, are already pre-assembled on the manifolds and are thus extremely economical in terms of time and space when it comes to installation.

NovaDrive and TopDrive fit almost all generally available valves and, thanks to their bayonet or click connector, are quick and easy to fit.



THE CONTROL CENTRE

The NovaStat room thermostats activate actuators on demand. This allows room temperatures to be adjusted individually and reduces heating costs. Reduction of the room temperature by only 1 °C means a reduction of heating costs by about 6 %. The wide product range, designed with price and performance in mind, offers a solution for every need. Together with the expandable NovaMaster connecting modules, the room thermostats can also master complex requirements. Both NovaStat and NovaMaster are available as cable and radio versions.

COMFORT AND ENERGY EFFICIENCY WITH UNDERFLOOR HEATING SYSTEMS

Comfort and energy efficiency are key in any modern heating system and provide convincing arguments why a panel heating system is the first choice for home owners and investors alike.

PANEL HEATING SYSTEMS ARE PART OF MODERN ENERGY SYSTEMS

Whether they are used in private homes or open-plan office buildings, low-temperature heating systems offer cozy comfort as well as excellent conditions for using renewable energies and the energy-efficient use of modern heating systems, such as calorific heating systems or heat pumps. When combined with low temperature heat generation, a panel heating system produces a modern, energy-efficient heating system.

REGULATION OF PANEL HEATING SYSTEMS

Underfloor heating systems require a precise regulation of the flow rate in the individual heating circuits because low temperature panel heating and high temperature heating systems are slow to respond to adjustments. This response to regulation is largely influenced by the hydronic characteristics of panel heating systems:

- The entire floor or wall surface is used to transmit the heat
- The heat is distributed by means of numerous heating circuits, consisting of long lengths of narrow gauge piping
- The heat is transmitted at a low temperature and with low-level spread

LINK FOR HEAT DISTRIBUTION

Together with the relevant regulators, such as shutoff valves and actuators, the heating circuit distributor is thus an important link between the heat generator and the panel heating system and ensures an even level of heat throughout the property.

BALANCING THE SYSTEM HYDRONICS

During commissioning it is important to balance the system hydraulics so that all heat consumers are supplied with hot water in line with their heat requirements. In the main distribution system the hot water volume flow is limited by means of hydronic balancing to the flow rates that correspond to the calculated heat output in the various sections of the building.

FOCUSED DISTRIBUTION FOR INDIVIDUAL HEATING CIRCUITS

In order to achieve the required room temperatures within one floor of a building, the flow rates for the relevant heating circuits in underfloor heating systems are also regulated.

TopMeter balancing valves make it possible to precisely adjust and immediately check the flow rate: the rate can be adjusted and checked on the flow and return bars of the heating circuit distributor in liters per minute.

This makes it possible to regulate a panel heating system centrally by means of the heating circuit distributor and to achieve this on several heating circuits simultaneously, reducing the expenditure of time. The integrated memory function in the newly developed TopMeter Plus balancing valve allows the last flow rate setting to be reproduced even following shutoff of the flow.

FIRST CHOICE

The simple and efficient operation with the TopMeter means that installation companies can avoid costly adjustments. This makes the TopMeter from Taconova the first choice for regulating distribution systems.

YOUR TRUMP CARD IN SATISFYING CUSTOMERS

Taconova's area heating products are ideal for a wide variety of building types. Specialist planners and tradesmen will benefit from the security of these reliable system solutions and the satisfaction of their customers.

BENEFITS AT THE PLANNING STAGE

- Reliable compliance with the system layout thanks to simple regulation
- Smooth system operation thanks to automatic venting and lockable flow rate adjustment
- The regulating functions can be expanded at a later point by means of retrofittable actuators
- The comprehensive range, including regulating components, makes tendering processes easy

BENEFITS AT THE INSTALLATION STAGE

- Pre-assembled, ready-to-install underfloor heating systems with a minimum number of screw connections
- Time-saving, reproducible regulation of the flow rates in liters per minute without requiring regulation
- Simple control of flow rates during maintenance and testing without requiring measurement devices
- Precise regulation for constant room temperatures

Manifolds

The completely pre-assembled TacoSys stainless steel manifolds are designed for two to twelve heating circuits. The equipment also includes, among other things, the TopMeter (TacoSys High End) and the TacoVent Vent. The innovative TacoDrive actuators with first-open function and the TopMeter Plus balancing valves with reproducible balancing function are preinstalled in the latest distribution system, the TacoSys Pro.

- TacoSys Pro
- TacoSys High End
- TacoSys Connect

Balancing Valves

With the well-known and proven balance valve Top Meter, the flow in heating circuits can be directly regulated, indicated and turned off. With the new balancing valve TopMeter Plus, the last flow rate set can be reproduced using an additional stop ring. It contains the double function according to DIN EN 1264-4

- TopMeter Plus
- TopMeter Supply
- TopMeter Return

Heating and cooling energy generation	Heating and cooling energy distribution (room climate)	Sanitary systems
-	<ul style="list-style-type: none"> ▪ Underfloor heating ▪ Radiators ▪ Chilled and heated ceilings ▪ Fan coils and chill beams ▪ Concrete cores 	-

TACOSYS PRO

UNDERFLOOR HEATING CIRCUIT MANIFOLD

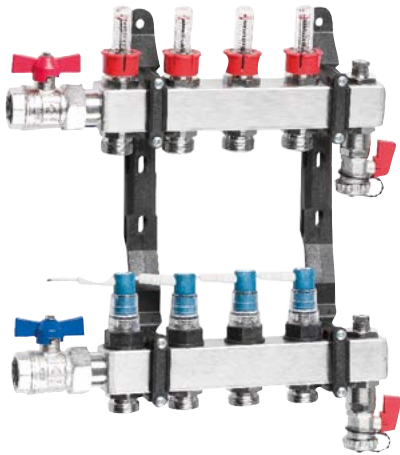

The TacoSys Pro heating circuit manifolds from Taconova ensure the perfect distribution of heat throughout the entire house.

DESCRIPTION

The TacoSys Pro is a next-generation heating circuit manifold, which now comes with two new components. Firstly, the TopMeter Plus balancing valve, which is positioned in the supply and allows reproducible adjustment of the flow control at the stop limit. The last setting can thus be restored any time in compliance with DIN-EN 1264-4. Secondly, the TacoDrive valve drive unit, in which case the actuator has been integrated directly in the valve. The actuator is extremely compact and has a reversible first-open function, with the force of the expansion element acting directly on the valve.

Different valve positions result in different flow volumes. They thus guarantee individual regulation of the room temperature, precisely tailored to the requirements of your customers.

The TacoVent Vent air vent ensures fully automatic ventilation of supply and return, thus enhancing operating safety and user convenience. The underfloor heating circuit manifolds are supplied fully pre-assembled and ready-for-connection. The high-quality stainless steel TacoSys Pro manifold can be supplied with between two and twelve heating circuits.

ADVANTAGES

- Balancing with TopMeter Plus in the supply circuit
- Directly integrated TacoDrive valve drive unit
- TacoDrive offers high protection class (IP54)
- Integrated valve position indicator
- Compliance with DIN-EN 1264-4 standard
- Light, modern and robust stainless steel manifold bars
- Ventilation with the fully automatic TacoVent Vent air vent
- Glass-fiber reinforced plastic stay for sound-damping assembly

It fulfills all requirements with respect to performance, energy efficiency, reliability, durability and comfort.

INSTALLATION POSITION

For riser pipe assembly left and right, and overhead.

OPERATION

Manifold supply and return bars are connected to the heating system. The heating and cooling circuits can be connected effortlessly to the Eurocone outlets using the likewise optionally available fittings. The designed flow volume is set for each circuit at the TopMeter Plus. The room thermostats together with the actuators ensure comfortable conditions in individual rooms.

BUILDING CATEGORIES

- Apartment blocks, housing estates, multiple dwelling units
- Residential care facilities and hospitals
- Administration and service buildings
- Hotels and restaurants
- School buildings and sports halls, sports facilities
- Commercial and industrial buildings

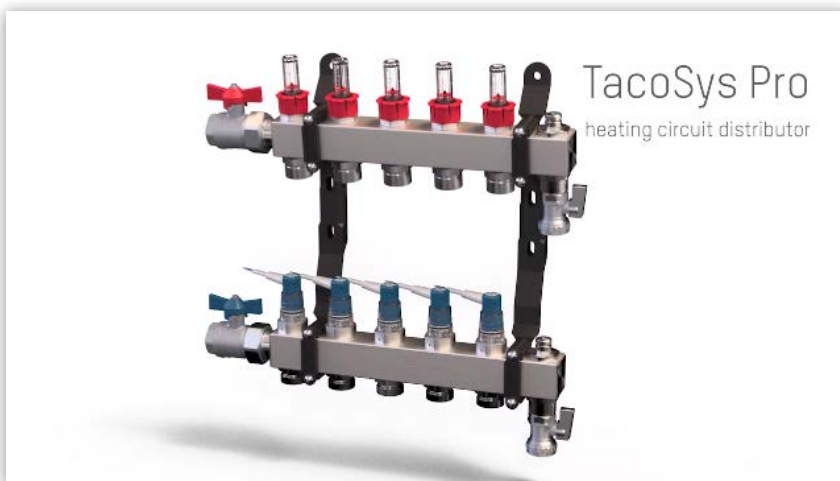

SPECIFICATION TEXT

See www.taconova.com

TECHNICAL DATA

General

- Medium temperature: -10 °C – + 60 °C
- Operating pressure $P_{0,max}$: 6 bar
- Display accuracy: $\pm 10\%$ of final value
- k_{vs} value and measurement range according to „pressure loss diagram“
- Heating circuit connections: $\frac{3}{4}$ " eurocone

Material

- Bars: stainless steel
- Internal parts: Nickel-plated brass, heat-resistant and impact-proof plastics
- Seals: EPDM O-rings
- Securing brackets: Plastic, glass fiber-reinforced

Actuator

- Type: Normally closed (NC)
- Ambient temperature: 0 - 50 °C
- Opening/closing time: approx. 3 minutes
- Visual inspection of expansion element
- Reversible first-open
- Nominal stroke: 4 mm
- Protection class of actuator: IP54
- Protection class II

Electrical connection data

- Rated voltage: 230 V, 50/60 Hz
- Permissible voltage deviation: $\pm 10\%$
- Operating efficiency: 1.8 W
- Inrush current: 230 V: 0.6 A for max. 100 ms
- Recommended fuse: 0.35 A slow-acting, as per DIN 41662
- Connection cable length: 1 m
- Connection cable: 2 x 0.75 mm², PVC with connector

Flow media

- Heating water (VDI 2035; SWKI BT 102-01; ÖNORM H 5195-1)
- Water free of chemical additives

SYSTEM COMPONENTS

Room thermostats as well as distribution cabinets; see separate data sheets

TYPE OVERVIEW

TacoSys Pro | Heating manifold with TopMeter Plus, TacoDrive and $\frac{3}{4}$ " ball valve

Heating circuits	Flow range	Flow range
	0 – 2,5 l/min	0 – 5 l/min
	Order No.	Order No.
2	288.5002.000	288.6002.000
3	288.5003.000	288.6003.000
4	288.5004.000	288.6004.000
5	288.5005.000	288.6005.000
6	288.5006.000	288.6006.000
7	288.5007.000	288.6007.000
8	288.5008.000	288.6008.000
9	288.5009.000	288.6009.000
10	288.5010.000	288.6010.000
11	288.5011.000	288.6011.000
12	288.5012.000	288.6012.000

Variants with TopMeter Supply and TacoDrive or TopMeter Plus with plastic valve on request.

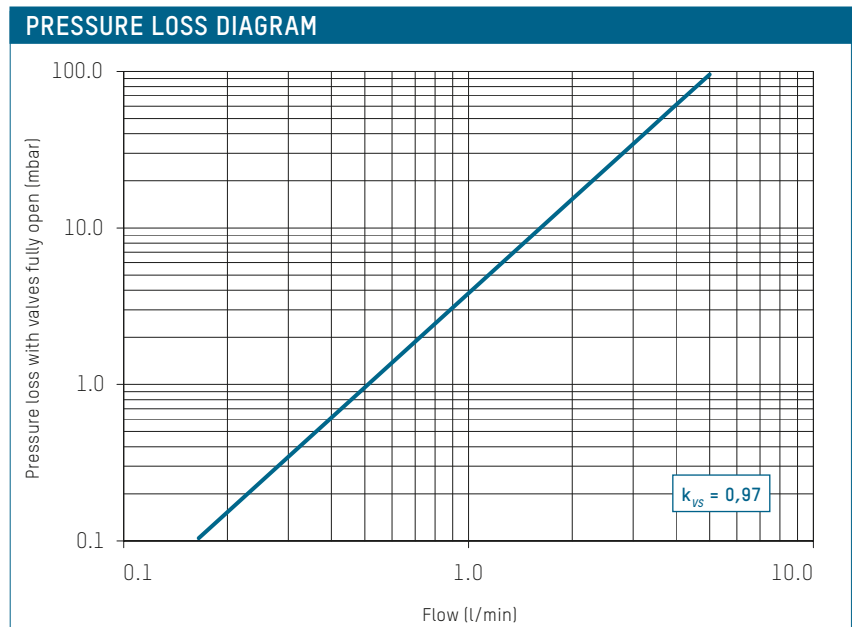

NOTE
We recommend that manifolds with 1" ball valves be used if there are eight or more heating circuits and their valves are fully opened (> 2.5 l/min), in order to avoid potential flow noise.

NOTE

Adjusting the TacoSys Pro manifold

The floor heating circuits are regulated directly at the manifold using the TopMeter Plus balancing valves. The adjustment process is carried out when the circulating pump is running. All of the valves in the heating circuit must be fully open for adjustment. The first-open function may have to be activated.

- 1 Start at the TopMeter Plus of the heating circuit with the smallest flow volume
- 2 Set the calculated volume flow by rotating the red regulation knob
- 3 Read off the settings from the red indicator collar in the porthole
- 4 Repeat the adjustment process for all of the heating circuits
- 5 Next, check the first values and re-adjust if necessary
- 6 Once adjustment is complete, note the corresponding flow values on the manifold or in the planning documents

DIMENSIONAL DRAWING

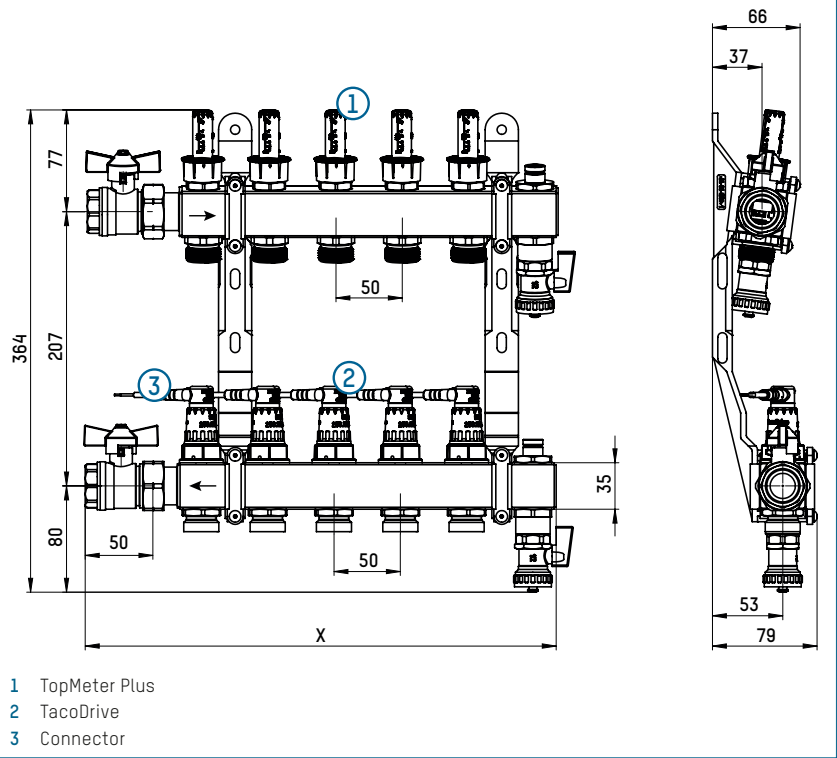

LENGTH DIMENSIONS

Heating circuits	Length X (mm)	Heating circuits	Length X (mm)
2	204	8	504
3	254	9	554
4	304	10	604
5	354	11	654
6	404	12	704
7	454		

ACCESSORIES



SCREW CONNECTIONS

Two nickel-plated compression fittings, complete, for plastic and multilayer pipes, with molded seal, slotted compression ring and barrier seal.

Order No.	Dimensions	G x mm
210.8614.003	∅ 14 x 2	3/4" x 14
210.8616.003	∅ 16 x 2	3/4" x 16
210.8617.003	∅ 17 x 2	3/4" x 17
210.8618.003	∅ 18 x 2	3/4" x 18
210.8620.003	∅ 20 x 2	3/4" x 20

SPARE PARTS



BALL VALVE

Order No.	Dimensions	Length	Handle color
298.8630.001	3/4"	50 mm	red
298.8631.001	3/4"	50 mm	blue
298.8628.001	1"	65 mm	red
298.8629.001	1"	65 mm	blue



BOILER FILLING AND DRAIN VALVE

The boiler filling and drain valve is only available with red handle

Order No.	Handle color
296.8653.001	red



TOPMETER PLUS BALANCING GROUP

Order No.	Range
298.8610.001	0 – 2.5 l/min
298.8611.001	0 – 5 l/min



TACODRIVE VALVES AND MANUAL ADJUSTMENT FOR TACOSYS PRO

Order No.	Type
298.8622.001 (1)	Drive with valve for TacoDrive
298.8624.001 (2)	TacoDrive complete (drive upper with valve, base part with fine thread)
298.2270.100 (3)	Drive upper part for TacoDrive (for nickel-plated nipple)
298.8635.001 (4)	TacoDrive valve with manual adjustment
298.8636.001 (5)	Manual adjustment for TacoDrive



AIR VENT GROUP WITHOUT FILLING AND DRAINING VALVE

Order No.
298.8604.001

The pipe sections shown are for illustrative purposes only and are not included in the replacement part packs.

TACOSYS

UNDERFLOOR HEATING MANIFOLD

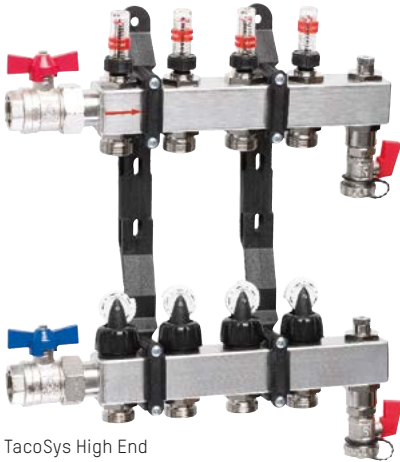

TacoSys High End



TacoSys Connect

The TacoSys heating circuit manifolds from Taconova ensure the perfect distribution of heat throughout the entire house.

DESCRIPTION

Thanks to their innovative technology, TacoSys heating circuit manifolds work reliably and according to requirements, and are particularly cost-saving.

The manifold valves are ready to accept Taconova actuators. The manual control valves enable reproducible, manual flow regulation. Different valve settings result in different flow volumes. They thus guarantee individual regulation of the room temperature, precisely tailored to the requirements of your customers.

The vent valves TacoVent Vent caters for fully automatic ventilation of sup-

ply and return, thus enhancing operating safety and user convenience. Whether for use with underfloor heating or radiators, TacoSys offers you high-quality manifold systems that satisfy every customer need. The underfloor heating manifolds are supplied fully pre-assembled and ready-for-connection, in a robust, non-slip cardboard packing case. The high-quality stainless steel manifold is available in different versions, making it the ideal solution for heating systems of any type. Designed for between two and twelve heating circuits, it meets every requirement in terms of efficiency and durability.

ADVANTAGES

- Lightweight, modern and robust stainless steel manifold bars
- Balancing with the proven TopMeter in supply circuit
- Cone-shaped valve form for fine flow adjustment
- Handwheel positioning with ratchet function for reproducible flow control
- Ventilation with the fully automatic TacoVent Vent air vent
- Glass-fiber reinforced plastic stay for sound-damping assembly
- 100% leakage test

INSTALLATION POSITION

For riser pipe assembly left, right and overhead.

OPERATION

Manifold supply and return bars are connected to the heating system. The heating/cooling circuits can be connected to the two to twelve Eurocone outlets easily using the optional fittings. The designed flow volume is set for each circuit at the TopMeter. Handwheel or room thermostats with actuators ensure comfortable conditions in individual rooms.

BUILDING CATEGORIES

- Apartment blocks, housing estates, multiple dwelling units
- Residential care facilities and hospitals
- Administration and service buildings
- Hotels and restaurants, industrial kitchens
- School buildings and sports facilities
- Commercial and industrial buildings

SYSTEM/BASIC DIAGRAM

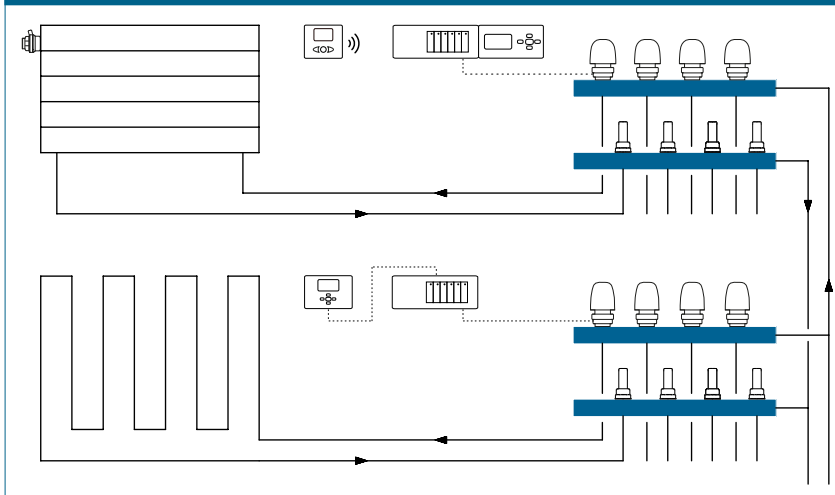

SPECIFICATION TEXT

See www.taconova.com

TECHNICAL DATA

General

- Medium temperature:
-10 °C to + 70 °C
- Operating pressure $P_{0,max}$:
 - TacoSys High End: 6 bar
 - TacoSys Connect: 8 bar
- Display accuracy:
±10% of final value
- k_{vs} values and measuring range see
„pressure loss diagram“
- Heating circuit connections:
¾" eurocone

Material

- Bars: Stainless steel
- Internal parts: Nickel-plated brass, heat-resistant and impact-proof plastics
- Seals: EPDM O-rings
- Securing brackets: Plastic, glass fiber-reinforced

Fluids

- Heating water
(VDI 2035; SWKI BT 102-01; ÖNORM H 5195-1)
- Water free of chemical additives

SYSTEM COMPONENTS

TopDrive and NovaDrive electro-thermal actuators, room thermostats and distribution cabinets: See separate datasheets.

TYPE OVERVIEW

TacoSys | Heating manifolds

Heating circuits	TacoSys High End* (TopMeter Supply)		TacoSys Connect**
	0 – 2.5 l/min	0 – 5 l/min	
2	286.4002.000	286.1002.000	287.1302.000
3	286.4003.000	286.1003.000	287.1303.000
4	286.4004.000	286.1004.000	287.1304.000
5	286.4005.000	286.1005.000	287.1305.000
6	286.4006.000	286.1006.000	287.1306.000
7	286.4007.000	286.1007.000	287.1307.000
8	286.4008.000	286.1008.000	287.1308.000
9	286.4009.000	286.1009.000	287.1309.000
10	286.4010.000	286.1010.000	287.1310.000
11	286.4011.000	286.1011.000	287.1311.000
12	286.4012.000	286.1012.000	287.1312.000

* With ¾" IT x 1" OT ball valves. Versions without ball valves on request (see price list).

** Without ball valve

PRESSURE LOSS DIAGRAM

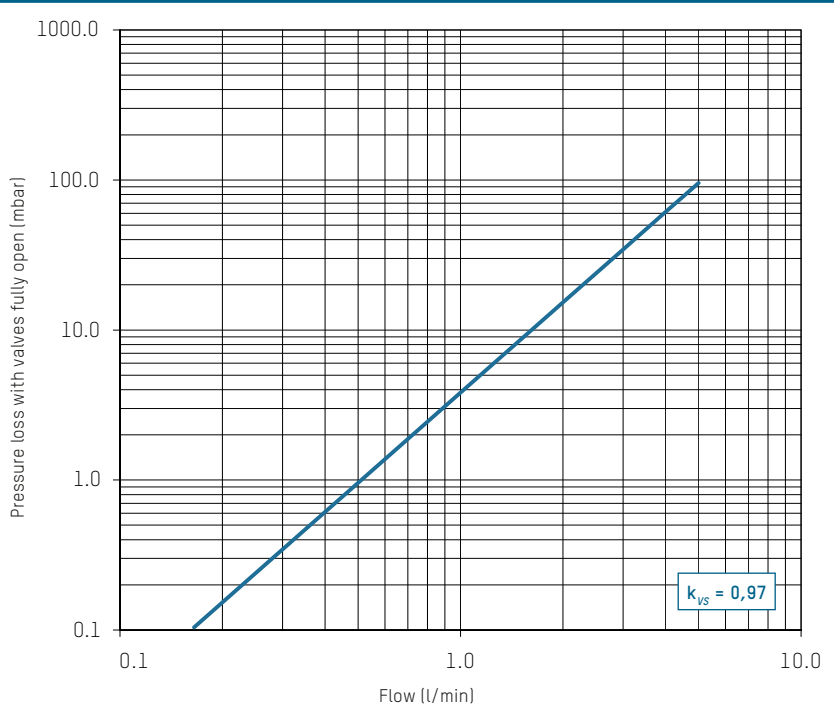

NOTE

In order to avoid potential flow noise, we recommend that manifolds with 1" ball valves be used if there are eight or more heating circuits and their valves are fully opened (≥ 2.5 l/min).

NOTE

Adjusting the TacoSys manifold

The floor heating circuits are adjusted at the TacoSys stainless steel manifold using the advance or return TopMeter.

The adjustment process is carried out with the circulating pump running. All of the valves in the heating circuit must be fully open for adjustment.

It may be necessary to remove the electro-thermal actuators.

- 1 Start at the TopMeter of the heating circuit with the smallest flow volume
- 2 Set the calculated volume flow by rotating the black plastic spindle
- 3 Read off the settings from the red indicator collar in the porthole
- 4 Repeat the adjustment process for all of the heating circuits
- 5 Next, check the first values and re-adjust if necessary
- 6 Once adjustment is complete, note the corresponding flow values on the manifold or in the planning documents

DIMENSIONAL DRAWING

Underfloor heating manifold with TopMeter Supply (in supply circuit)

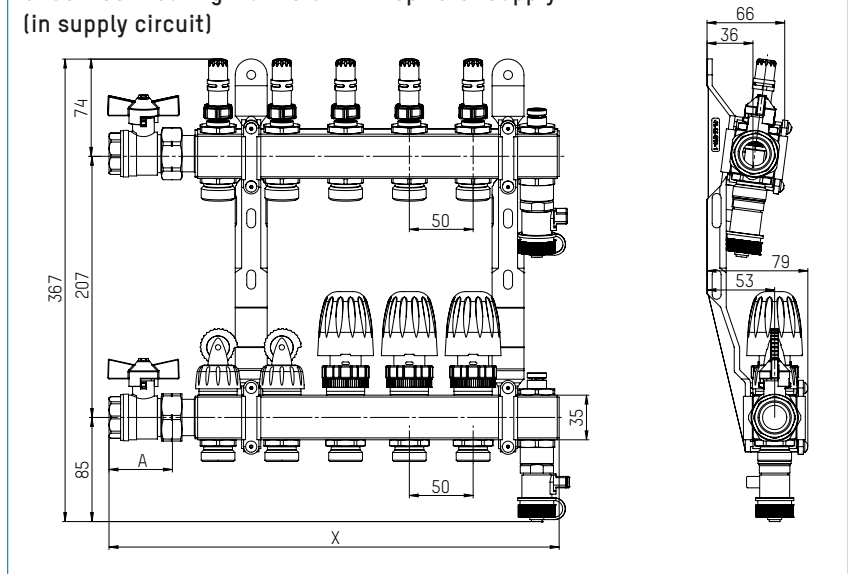

LENGTH DIMENSIONS

Heating circuits	Length X with 3/4" ball valve
2	213 mm
3	263 mm
4	313 mm
5	363 mm
6	413 mm
7	463 mm
8	513 mm
9	563 mm
10	613 mm
11	663 mm
12	713 mm

ACCESSORIES



SCREW CONNECTIONS

Two nickel-plated compression fittings, complete, for plastic and multilayer pipes, with molded seal, slotted compression ring and barrier seal.

Order no.	Dimension	G x mm
210.8614.003	Ø 14 x 2	¾" x 14
210.8616.003	Ø 16 x 2	¾" x 16
210.8617.003	Ø 17 x 2	¾" x 17
210.8618.003	Ø 18 x 2	¾" x 18
210.8620.003	Ø 20 x 2	¾" x 20

SPARE PARTS



MANUAL REGULATOR

The ratchet feature on the manual control valves enables a reproducible valve setting. The valves are preinstalled in the TacoSys High End and TacoSys Value as standard.

Order no.
296.8651.001



BALL VALVE

Order no.	Dimension	Length	Handle colour
298.8630.001	¾"	50 mm	red
298.8631.001	¾"	50 mm	blue
298.8628.001	1"	65 mm	red
298.8629.001	1"	65 mm	blue



BOILER FILLING AND DRAIN VALVE

The boiler filling and drain valve is only available with red handle

Order no.	Handle colour
296.8653.001	red



VALVE GROUP WITHOUT MANUAL REGULATOR TOPMETER SUPPLY

Order no.	Range
298.8609.001	0 – 2.5 l/min
298.8606.001	0 – 5 l/min



VALVE ASSEMBLY WITHOUT MANUAL REGULATOR

Order no.	Material
298.8613.001	Plastic

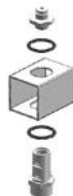

AIR VENT GROUP WITHOUT FILLING/DRAINING VALVE

Order no.
298.8604.001

The pipe sections shown are for illustrative purposes only and are not included in the replacement part packs.

MANIFOLD CABINETS



Housing of TacoSys heating manifold systems in appropriate manifold cabinets

ADVANTAGES

- High-quality material
- Flush mounted and surface mounted versions available in RAL 9016
- Scratch-, shock- and corrosion-proof coating surface

DESCRIPTION

Cabinets made from robust sheet steel painted in RAL 9016 with universal pre-punched areas for pipe outlets. Removable and adjustable screed baffle plate. Pipe deflection rail with twist/clip lock. Rounded edges on frame. With height-adjustable cabinet feet. Removable and depth-adjustable front panel.

INSTALLATION POSITION

Surface- or flush-mounted.

OPERATION

The choice of correct cabinet size depends on the number of heating circuits and/or the TacoSys manifold used.

BUILDING CATEGORIES

- Apartment blocks, housing estates, multiple dwelling units
- Residential care facilities and hospitals
- Administration and service buildings
- Hotels and restaurants
- School buildings and sports halls, sports facilities
- Commercial and industrial buildings

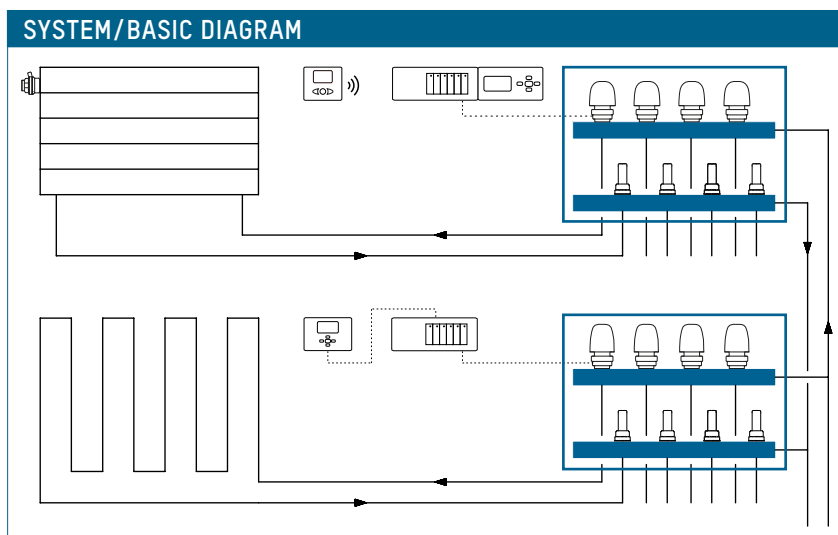

MANIFOLD CABINETS

SPECIFICATION TEXT

See www.taconova.com

TECHNICAL DATA

General

- Dimensions: See overview of types
- Color: RAL 9016

NOTE

White baffle plate (RAL 9016) for flush-mounted cabinets on request.

TYPE OVERVIEW

Flush-mounted cabinet

For between two and twelve heating circuits, cabinet sizes 1 to 6

Order no.	Cabinet size	Wall recess H × W × D (mm)
282.4203.000	1	720-790 × 455 × 120-160
282.4204.000	2	720-790 × 510 × 120-160
282.4206.000	3	720-790 × 595 × 120-160
282.4207.000	4	720-790 × 745 × 120-160
282.4209.000	5	720-790 × 865 × 120-160
282.4211.000	6	720-790 × 1045 × 120-160

Surface-mounted cabinet

For between two and twelve heating circuits, cabinet sizes A to E

Order no.	Cabinet size	External dimension H × W × D (mm)
282.6204.000	A	622-712 × 442 × 125
282.6206.000	B	622-712 × 581 × 125
282.6207.000	C	622-712 × 731 × 125
282.6209.000	D	622-712 × 881 × 125
282.6212.000	E	622-712 × 1031 × 125

DIMENSIONAL DRAWING

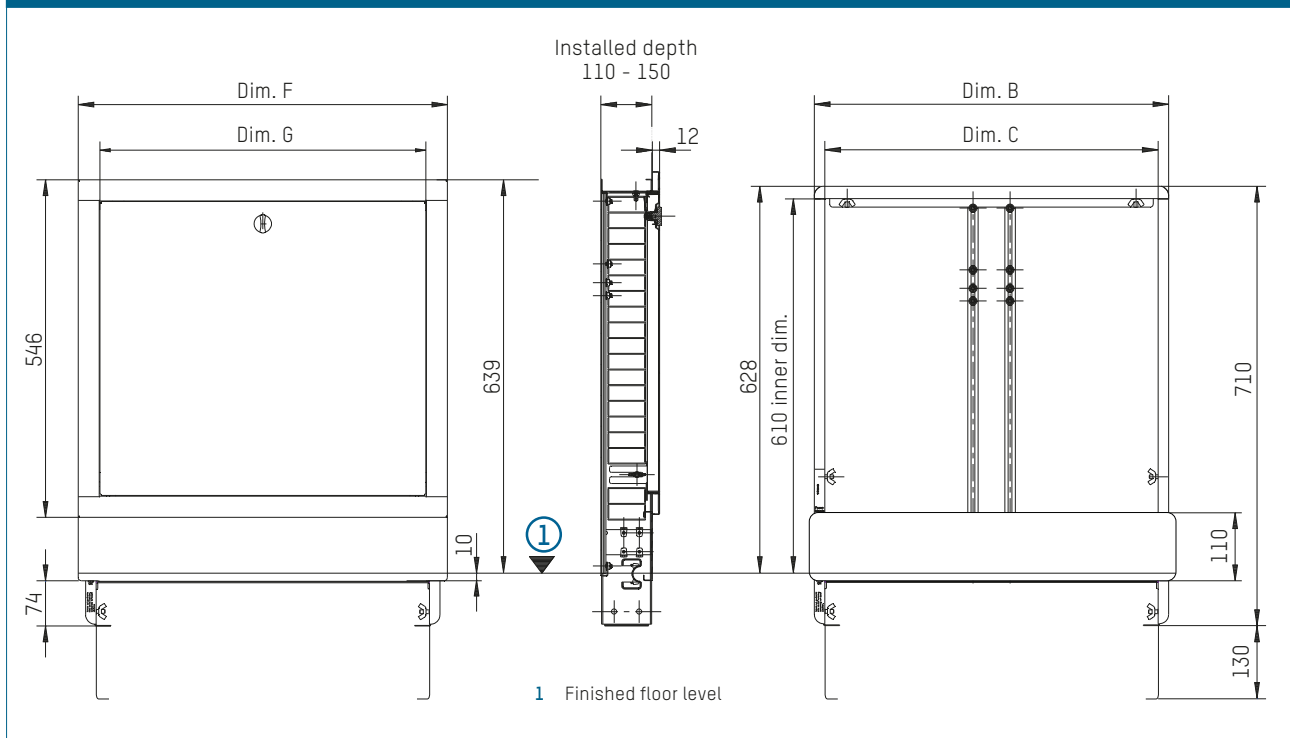

MEASUREMENT TABLE

Dim./type	1	2	3	4	5	6
Dim. B	435	490	575	725	875	1025
Dim. C	400	455	540	690	840	990
Dim. F	460	515	600	750	900	1050
Dim. G	390	445	530	680	830	980

SELECTING THE RIGHT CABINET SIZE

- The size of the manifold is determined by the number of manifold circuits
- Decision as to whether a heat counter set needs to be installed
- Can be derived from table in accordance with the number of heating circuits

LEGEND

Manifold system with ball valves in supply and return circuit:

0 = without heat counter set

◊ = with horizontal heat counter set

Δ = with vertical heat counter set

Cabinet size		Flush-mounted cabinets						Surface-mounted cabinets				
		1	2	3	4	5	6	A	B	C	D	E
Internal Edimensions		401	455	540	690	840	990	438	577	727	877	1027
Number of heating circuits	2	0 Δ		◊				0 Δ	◊			
	3	0 Δ		◊				0 Δ	◊			
	4	0	Δ		◊			0	Δ	◊		
	5		0	Δ	◊			0	Δ	◊		
	6			0 Δ	◊				0 Δ	◊		
	7			0	Δ	◊			0	Δ	◊	
	8				0 Δ	◊			0	Δ	◊	
	9				0 Δ	◊				0 Δ	◊	
	10				0	Δ	◊			0	Δ	◊
	11					0 Δ	◊			0	Δ	◊
	12					0 Δ	◊				0 Δ	◊

MIXING STATION UNIVERSAL

FOR UNDERFLOOR HEATING MANIFOLDS



The mixing station supplies heating manifolds with the required flow rate and in the process regulates and monitors the flow temperature.

DESCRIPTION

The mixing station is a flexible and compact pump assembly for direct installation in heating manifolds. The station is used especially for avoiding installation of a second, costly low-temperature pipework between the boiler and underfloor heating manifold.

The boiler manifold and mixing valve for the underfloor heating loop in the central pump room can also be dispensed with.

When the mixing station is installed directly in the apartment at the heating manifold, adjustments can be performed decentrally for every apartment in accordance with the

individual needs of the user and the type of floor covering.

The station therefore guarantees optimal heating comfort for all occupants and ensures safe operation of the system thanks to the external safety temperature limiter. The mixing station can be combined ideally with heating manifolds (TacoSys or others) together with radiator heating systems.

ADVANTAGES

Compact

- Comes equipped with all the necessary valves and components

Secure

- Intrinsic safety of station with external safety temperature limiter

Simple

- Simple adjustment and reading of the required flow temperature

Efficient

- Energy savings thanks to high-efficiency pump

Flexible

- The center distance between the flow and return can be adjusted flexibly through the use of eccentric connectors

INSTALLATION POSITION

Left-, right-, and over-head assembly is possible at the hot water inlet in front of the heating manifold.

OPERATION

The required flow temperature can be preset at the heating manifold by means of the integrated thermostatic mixing valve and then regulated subsequently. The pump is switched off by an external safety temperature limiter if the flow temperature of approx. 50°C is exceeded.

BUILDING CATEGORIES

All building categories with integrated panel heating combined with radiator heating.

SYSTEM/BASIC DIAGRAM

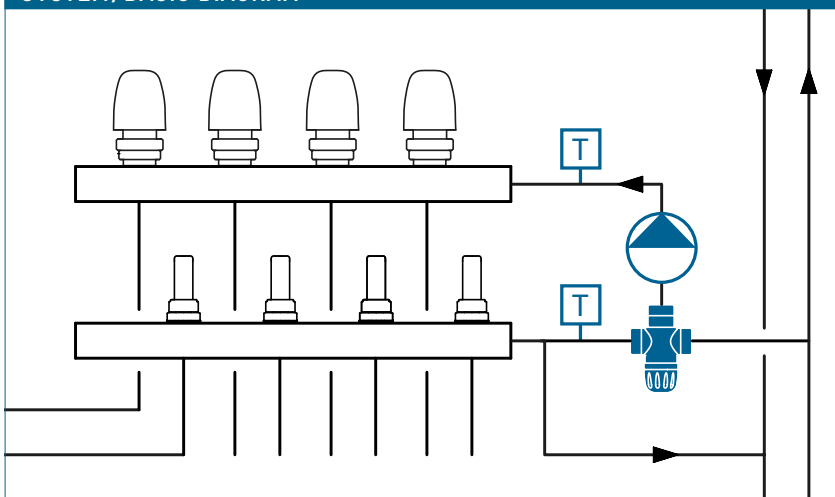

SPECIFICATION TEXT

See www.taconova.com

TECHNICAL DATA

General

- Operating temperature: -10 °C to + 70 °C
- Max. operating pressure $P_{B \max}$: 6 bar
- Adjustment range mixing valve: 20 – 50 °C
- Safety temperature limit 50 °C: $\pm 3\%$
- Residual pump head in accordance with flow rate and pressure loss diagrams

Materials

- Pipes: Stainless steel 1.4400
- Terminal nuts und eccentric connectors: Brass, nickel-plated
- Seals: EPDM O-rings

Flow media

- Heating water (VDI 2035; SWKI BT 102-01; ÖNORM H 5195-1)
- Water free of chemical additives

SYSTEM COMPONENTS

TacoDrive, TopDrive and NovaDrive electro-thermal actuators, room thermostats as well as distribution cabinets and heating manifolds: See separate datasheets.

TYPE OVERVIEW

Mixing station with Taco high-efficiency pump and external safety temperature limiter

Order no.	Delivery head
296.8666.001	7 m

DIMENSIONAL DRAWING

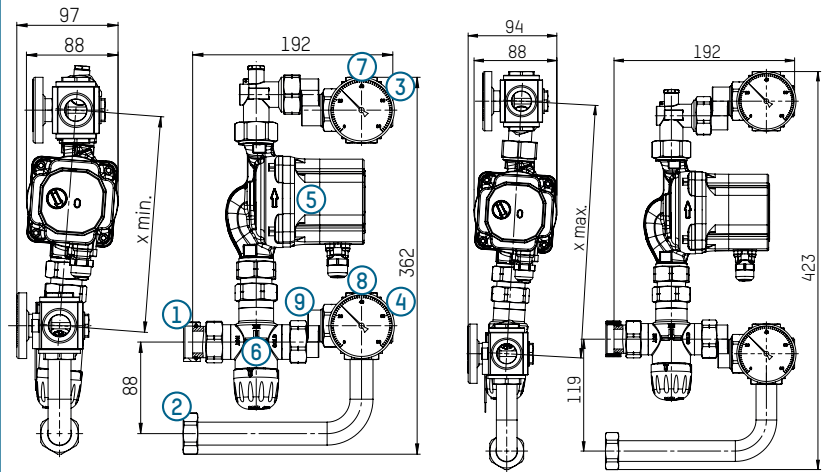

- | | |
|------------------------------------------------|-------------------------------------------|
| 1 Panel heating system flow [1" lock nut] | 6 NovaMix Value thermostatic mixing valve |
| 2 Panel heating system return [1" lock nut] | 7 Thermometer flow |
| 3 Manifold flow connection [1" outer thread] | 8 Thermometer return |
| 4 Manifold return connection [1" outer thread] | 9 Eccentric screw connection |
| 5 High-efficiency pump TacoFlow2 ADAPT 15-70 | |

Delivery condition dimensions X min = 207 mm

Adjustable using an eccentric connector to X max: 269 mm

Return flow connecting pipe adjustable between 92 mm and 123 mm

NOTE

Adjusting the mixing station

The mixing station is regulated by means of the integrated NovaMix Value mixing valve. The adjustment process is carried out when the circulating pump is running. All of the valves in the heating circuit must be fully open for adjustment. It may be necessary to remove the actuator drives.

- | | |
|------------------------------------------------------------------------------------------------|-----------------------------------------------------------------------------------------------------------------------------|
| 1 Check the flow temperature on the thermometer for the hot water flow. | 4 The set flow temperature should not exceed 45 °C. |
| 2 The flow temperature can be increased or decreased by rotating the blue plastic handle. | 5 A safety temperature limiter is located upstream from the circulating pump, which switches the pump off at approx. 50 °C. |
| 3 The flow temperature at the heating manifold may only be \leq the boiler flow temperature. | 6 Once adjustment is complete, note the corresponding flow temperature at the manifold or in the planning documents. |

**FLOW AND PRESSURE LOSS DIAGRAMS
MIXING STATION WITH OPEN VALVES AND TOPMETER**

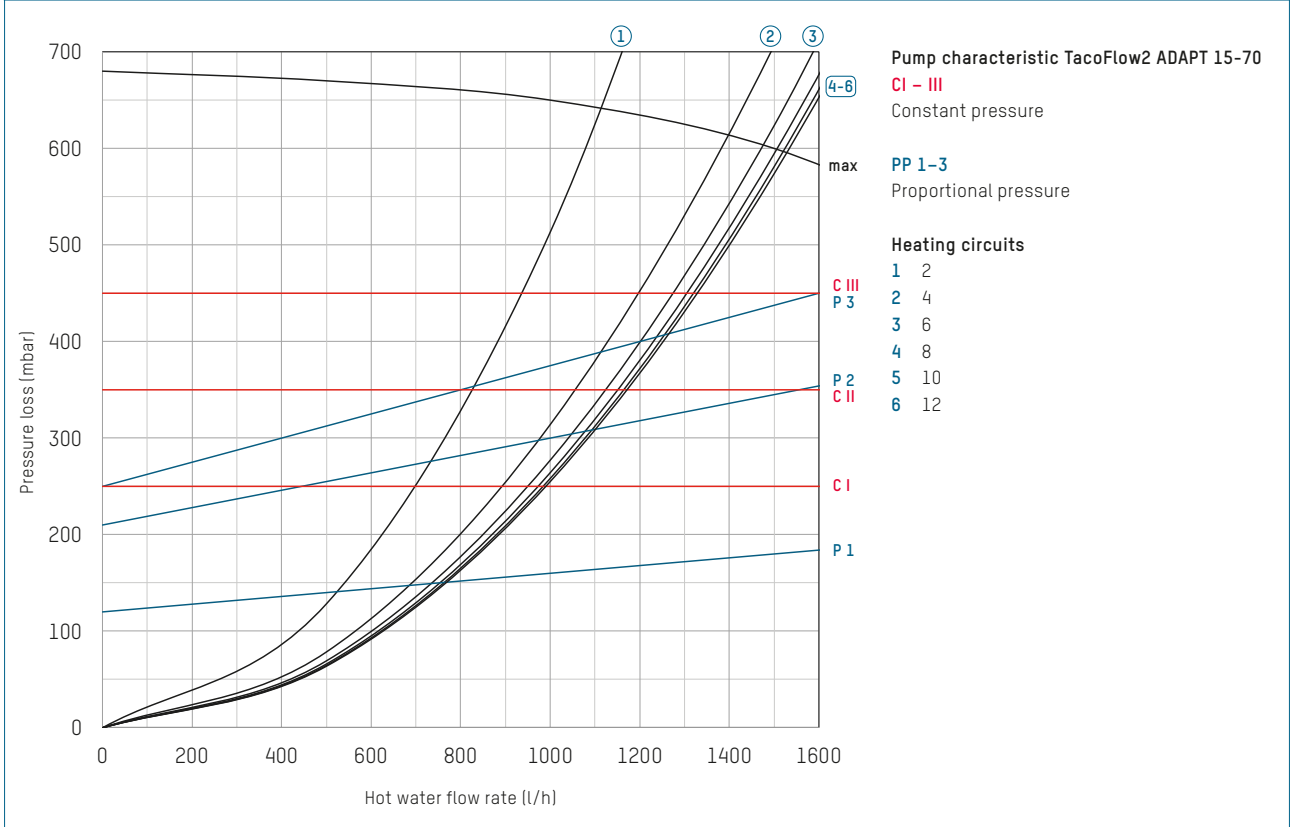

MIXING STATION TACOSYS

FOR TACOSYS UNDERFLOOR HEATING MANIFOLDS



The mixing station supplies heating manifolds with the required flow rate and in the process regulates and monitors the flow temperature.

DESCRIPTION

The mixing station is a compact pump assembly for direct installation in TacoSys underfloor heating manifolds. The station is used especially for avoiding installation of a second, costly low-temperature pipework between the boiler and underfloor heating manifold.

The boiler manifold and mixing valve for the underfloor heating loop in the central pump room can also be dispensed with.

When the mixing station is installed directly in the apartment at the heating manifold, adjustments can be performed decentrally for every apartment in accordance with the

individual needs of the user and the type of floor covering.

The station therefore guarantees optimal heating comfort for all occupants and ensures safe operation of the system thanks to the external safety temperature limiter. The mixing station can be combined ideally with TacoSys underfloor heating manifolds together with radiator heating systems.

ADVANTAGES

Compact

- Comes equipped with all the necessary valves and components

Secure

- Intrinsic safety of station with external safety temperature limiter

Simple

- Simple adjustment and reading of the required flow temperature

Efficient

- Energy savings thanks to high-efficiency pump

Fitting

- Fits perfectly to TacoSys underfloor heating manifolds
- Variable for horizontal or vertical installation

INSTALLATION POSITION

Left-, right-, and over-head assembly is possible at the hot water inlet in front of the heating manifold.

OPERATION

The required flow temperature can be preset at the heating manifold by means of the integrated thermostatic mixing valve and then regulated subsequently. The pump is switched off by an external safety temperature limiter if the flow temperature of approx. 50°C is exceeded.

BUILDING CATEGORIES

All building categories with integrated panel heating combined with radiator heating.

SYSTEM/BASIC DIAGRAM

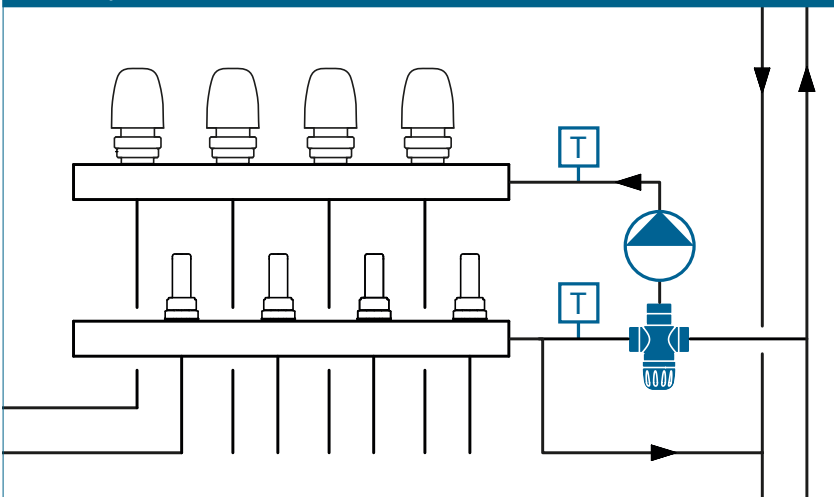

SPECIFICATION TEXT

See www.taconova.com

TECHNICAL DATA

General

- Operating temperature: -10 °C to + 70 °C
- Max. operating pressure $P_{B \text{ max}}$: 6 bar
- Adjustment range mixing valve: 20 – 50 °C
- Safety temperature limit 50 °C: $\pm 3\%$
- Residual pump head in accordance with flow rate and pressure loss diagrams

Materials

- Pipes: Stainless steel 1.4400
- Terminal nuts und eccentric connectors: Brass, nickel-plated
- Seals: EPDM O-rings

Flow media

- Heating water (VDI 2035; SWKI BT 102-01; ÖNORM H 5195-1)
- Water free of chemical additives

SYSTEM COMPONENTS

TacoDrive, TopDrive and NovaDrive electro-thermal actuators, room thermostats as well as distribution cabinets and heating manifolds: See separate datasheets.

TYPE OVERVIEW

Mixing station with Taco high-efficiency pump and external safety temperature limiter

Order no.	Delivery head
296.8667.001	7 m

DIMENSIONAL DRAWING

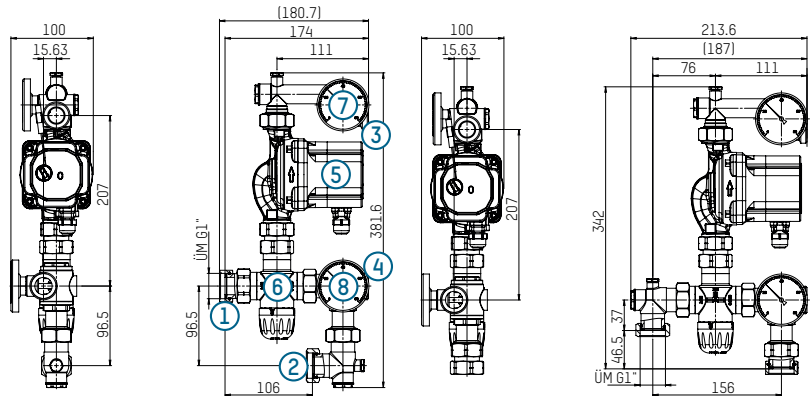

- | | |
|------------------------------------------------|-------------------------------------------|
| 1 Panel heating system flow [1" lock nut] | 6 NovaMix Value thermostatic mixing valve |
| 2 Panel heating system return [1" lock nut] | 7 Thermometer flow |
| 3 Manifold flow connection [1" outer thread] | 8 Thermometer return |
| 4 Manifold return connection [1" outer thread] | |
| 5 High-efficiency pump TacoFlow2 ADAPT 15-70 | |

NOTE

Adjusting the mixing station

The mixing station is regulated by means of the integrated NovaMix Value mixing valve. The adjustment process is carried out when the circulating pump is running. All of the valves in the heating circuit must be fully open for adjustment. It may be necessary to remove the actuator drives.

- | | |
|------------------------------------------------------------------------------------------------|-----------------------------------------------------------------------------------------------------------------------------|
| 1 Check the flow temperature on the thermometer for the hot water flow. | 4 The set flow temperature should not exceed 45 °C. |
| 2 The flow temperature can be increased or decreased by rotating the blue plastic handle. | 5 A safety temperature limiter is located upstream from the circulating pump, which switches the pump off at approx. 50 °C. |
| 3 The flow temperature at the heating manifold may only be \leq the boiler flow temperature. | 6 Once adjustment is complete, note the corresponding flow temperature at the manifold or in the planning documents. |

**FLOW AND PRESSURE LOSS DIAGRAMS
MIXING STATION WITH OPEN VALVES AND TOPMETER**

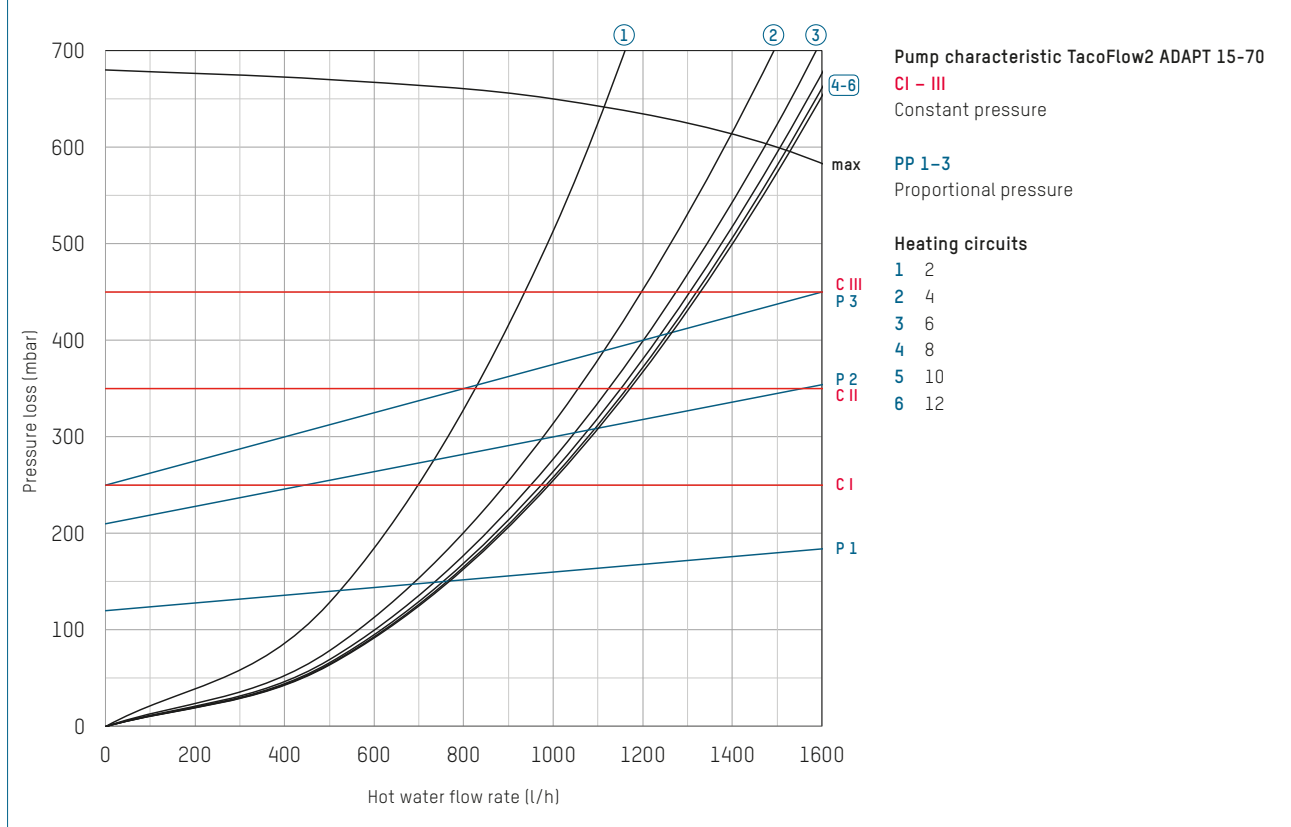

TOPMETER PLUS

BALANCING VALVE (FLOW)



Direct regulation, indication and isolation of flows from heating and cooling circuits in manifold flow pipe bars.

DESCRIPTION

The TopMeter Plus offers an easy and accurate method of adjusting the flow rates in heating and cooling circuits.

Thanks to intensive development work, it is possible to reproduce the last flow rate set using a stop ring. The DIN-EN 1264-4 standard is fulfilled.

Correct balancing of hydraulic circuits ensures optimum energy distribution, resulting in more efficient and economical operation in accordance with the energy saving regulations provided for by legislation.

With the TopMeter, any qualified fitter can set the appropriate flow rate on the premises in question, thus avoiding investments in training and expensive measuring devices.

INSTALLATION POSITION

The TopMeter is installed in the flow pipe bar of the manifold in a horizontal or vertical position.

The adaptation of the manifold must correspond to the manufacturer's specifications in accordance with the mounting dimension drawings.

ADVANTAGES

- Precise and quick balancing without diagrams, tables or measuring devices
- Flow rate displayed directly in l/min
- The last flow rate set can be reproduced using an additional stop ring
- The regulation knob is sealable
- Regulating valve with isolating facility
- Removable sight glass available as a replacement part
- Can be installed in any position

OPERATION

The flow measurement is based on the displacement principle of a baffle disc, which is inserted in a measuring tube. The position is conveyed to the sight glass on the indicator unit by means of a sliding bar, which fixes the baffle disc to the indicator unit. The scale printed on the sight glass allows the flow rate to be read with ease.

The opening cross-section at the valve is changed by rotating the regulation knob and consequently the required flow rate set or shut off fully. The stop ring is used in combination with the regulation knob to reproduce the flow rate.

BUILDING CATEGORIES

For installations in the heating and cooling area:

- Apartment blocks, housing estates, multiple dwelling units
- Residential care facilities, hospitals
- Administration and service buildings
- Hotels and restaurants, industrial kitchens
- School buildings and sports facilities
- Commercial and industrial buildings
- Facilities with partial use, such as barracks, camping sites



SPECIFICATION TEXT

See www.taconova.com

TECHNICAL DATA

General

- Medium temperature: -10 °C – +70 °C
- Operating pressure $P_{0,max}$: 6 bar
- System test pressure: max. 10 bar (20 °C)
- Measuring accuracy: $\pm 10\%$ of the highest nominal value (the change in viscosity must be taken into account with antifreeze additives)
- k_{VS} value and measuring range: see type overview
- External thread G 1/2" (cylindrical) as per ISO 228

Material

- Brass, heat-resistant plastics and stainless steel
- Seals: EPDM

Fluids

- Heating water (VDI 2035; SWKI BT 102-01; ÖNORM H 5195-1)
- Water and proprietary additives used against corrosion and freezing up to 50%

ADDITIONAL MODELS

See data sheet for TopMeter Supply and TopMeter Return

ASSEMBLY

When assembling the TopMeter in the manifold, the tightening torque must not exceed 20 Nm (brass TopMeter) or 10 Nm (plastic TopMeter).

SERVICE

The sight glass can be disassembled and replaced if necessary for servicing. See installation instructions (EA 1075).

TYPE OVERVIEW

TopMeter Plus | Balancing valve - Flow pipe

Order no.	DN	Measuring range	Nipple	k_{VS} (m³/h)
223.9502.100	15	0 – 2,5 l/min	Brass, nickel-plated	1,1*
223.9505.100	15	0 – 5,0 l/min	Brass, nickel-plated	1,1*
223.9506.100	15	0 – 6,0 l/min	Brass, nickel-plated	1,1*
223.9508.100	15	0 – 8,0 l/min	Brass, nickel-plated	1,1*
223.9502.116	15	0 – 2,5 l/min	Brass	1,1*
223.9505.116	15	0 – 5,0 l/min	Brass	1,1*
223.9506.116	15	0 – 6,0 l/min	Brass	1,1*
223.9508.116	15	0 – 8,0 l/min	Brass	1,1*
223.9702.116	15	0 – 2,5 l/min	Plastic	1,1*
223.9705.116	15	0 – 5,0 l/min	Plastic	1,1*

* The effective k_{VS} value depends on the counterpart used and the manifold geometry. Available on request with gpm and/or regulation knob in a different color. The definitive order number is assigned on the basis of the particular configuration.

DIMENSIONAL DRAWING

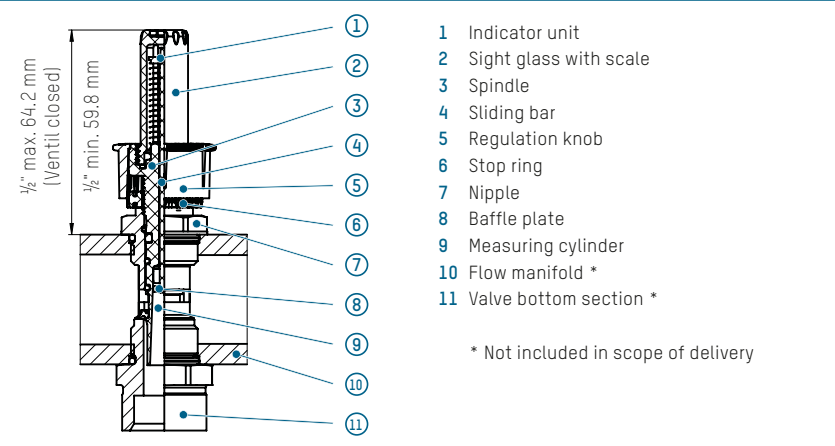

PRESSURE LOSS DIAGRAM

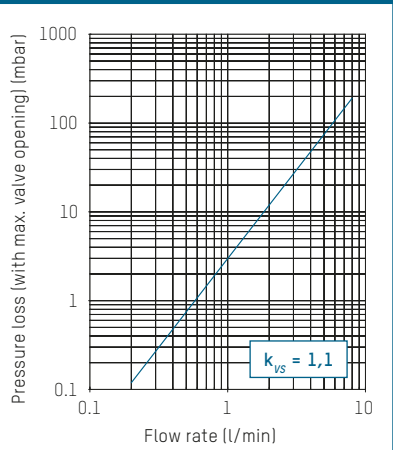

SPARE PARTS

Order no.	Sight glass
298.2317.000	0 – 2,5 l/min
298.2316.000	0 – 5,0 l/min
298.2318.000	0 – 6,0 l/min
298.2319.000	0 – 8,0 l/min

NOTE

Depending on the individual design of your application, the manifold (lower part of valve) has to be adapted to the TopMeter. For this purpose you will receive a drawing from us showing the required mounting dimensions. The sealing as well as the counterpart in the manifold remain in the responsibility of the customer in all cases.

TOPMETER SUPPLY

BALANCING VALVE (FLOW)



Direct regulation, indication and isolation of flows from heating and cooling circuits in manifold flow pipe bars.

DESCRIPTION

The TopMeter offers an easy and accurate method of adjusting the flow rates in heating and cooling circuits. Thanks to intensive development work and new technologies, the TopMeter can be integrated efficiently in the flow pipe bar to ensure reliable indicator values. Correct balancing of hydraulic circuits ensures optimum energy distribution, resulting in more efficient and economical operation in accordance with the energy saving regulations provided for by legislation.

With the TopMeter, any qualified fitter can set the appropriate flow rate on the premises in question, thus avoiding investments in training and expensive measuring devices.

INSTALLATION POSITION

The TopMeter is installed in the flow pipe bar of the manifold in a horizontal or vertical position. The adaptation of the manifold must correspond to the manufacturer's specifications in accordance with the mounting dimension drawings.

ADVANTAGES

- Precise and quick balancing without diagrams, tables or measuring devices
- Flow rate displayed directly in l/min
- Adjustments can be prevented using a lead seal
- Regulating valve with isolating facility
- Removable sight glass available as a replacement part
- Can be installed in any position

OPERATION

The flow measurement is based on the displacement principle of a baffle disc, which is inserted in a measuring tube. The position is conveyed to the sight glass on the indicator unit by means of a sliding bar, which fixes the baffle disc to the indicator unit. The scale printed on the sight glass allows the flow rate to be read with ease.

Turning the black spindle changes the opening profile of the valve and allows the desired flow rate to be set. The flow is isolated by turning the spindle fully.

BUILDING CATEGORIES

For installations in the heating and cooling area:

- Apartment blocks, housing estates, multiple dwelling units
- Residential care facilities, hospitals
- Administration and service buildings
- Hotels and restaurants, industrial kitchens
- School buildings and sports facilities
- Commercial and industrial buildings
- Facilities with partial use, such as barracks, camping sites

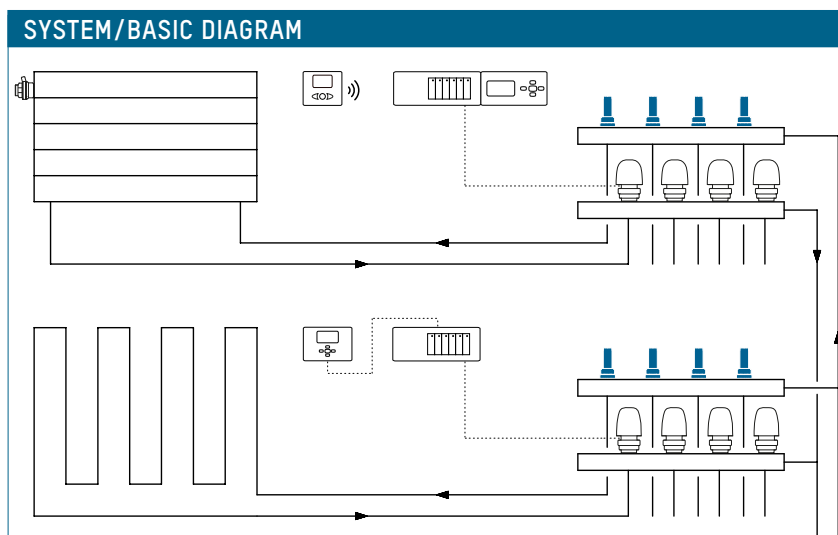

SPECIFICATION TEXT

See www.taconova.com

TECHNICAL DATA

General

- Medium temperature:
Brass TopMeter: -10 °C – +70 °C
Plastic TopMeter: -5 °C – +60 °C
- Operating pressure $P_{0,max}$: 6 bar
- System test pressure:
max. 10 bar (20 °C)
- Measuring accuracy:
±10% of the highest nominal value
(the change in viscosity must be taken into account with antifreeze additives)
- k_{VS} value and measuring range:
see type overview
- External thread G (cylindrical) as per ISO 228

Material

- Brass, heat-resistant plastics and stainless steel
- Seals: EPDM

Fluids

- Heating water
(VDI 2035; SWKI BT 102-01; ÖNORM H 5195-1)
- Water and proprietary additives used against corrosion and freezing up to 50%

ADDITIONAL MODELS

See data sheet for TopMeter Return

ASSEMBLY

When assembling the TopMeter in the manifold, the tightening torque must not exceed 20 Nm ($\frac{1}{2}$ "), 15 Nm ($\frac{3}{8}$ ") or 10 Nm (plastic TopMeter).

SERVICE

The sight glass can be disassembled and replaced if necessary for servicing. See installation instructions (EA 1075).

TYPE OVERVIEW

TopMeter Supply | Balancing valve - Flow pipe

Order no.	DN	G	Measuring range	Nipple	k_{VS} (m ³ /h)
223.6502.100	15	$\frac{1}{2}$ "	0 – 2,5 l/min	Brass, nickel-plated	1,1*
223.6505.100	15	$\frac{1}{2}$ "	0 – 5,0 l/min	Brass, nickel-plated	1,1*
223.6506.100	15	$\frac{1}{2}$ "	0 – 6,0 l/min	Brass, nickel-plated	1,1*
223.6508.100	15	$\frac{1}{2}$ "	0 – 8,0 l/min	Brass, nickel-plated	1,1*
223.6502.116	15	$\frac{1}{2}$ "	0 – 2,5 l/min	Brass	1,1*
223.6505.116	15	$\frac{1}{2}$ "	0 – 5,0 l/min	Brass	1,1*
223.6506.116	15	$\frac{1}{2}$ "	0 – 6,0 l/min	Brass	1,1*
223.6508.116	15	$\frac{1}{2}$ "	0 – 8,0 l/min	Brass	1,1*
223.6605.100	10	$\frac{3}{8}$ "	0 – 5,0 l/min	Brass, nickel-plated	1,1*
223.6605.116	10	$\frac{3}{8}$ "	0 – 5,0 l/min	Brass	1,1*
223.6702.XXX	15	$\frac{1}{2}$ "	0 – 2,5 l/min	Plastic	1,1*
223.6705.XXX	15	$\frac{1}{2}$ "	0 – 5,0 l/min	Plastic	1,1*

* The effective k_{VS} value depends on the counterpart used and the manifold geometry. Available on request with gpm and/or regulation knob in a different color. The definitive order number is assigned on the basis of the particular configuration.

DIMENSIONAL DRAWING

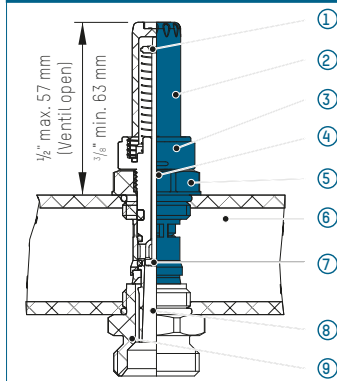

- 1 Indicator unit
- 2 Sight glass with scale
- 3 Spindle
- 4 Sliding bar
- 5 Nipple
- 6 Flow pipe manifold
- 7 Baffle disc
- 8 Measuring cylinder
- 9 Lower part of valve
- Scope of delivery

PRESSURE LOSS DIAGRAM

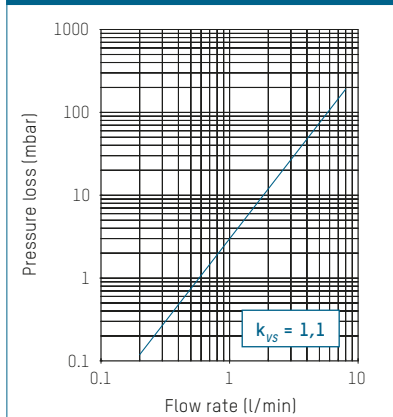

SPARE PARTS

Order no.	Sight glass
298.2317.000	0 – 2,5 l/min
298.2316.000	0 – 5,0 l/min
298.2318.000	0 – 6,0 l/min
298.2319.000	0 – 8,0 l/min

NOTE

Depending on the individual design of your application, the manifold (lower part of valve) has to be adapted to the TopMeter. For this purpose you will receive a drawing from us showing the required mounting dimensions. The sealing as well as the counterpart in the manifold remain in the responsibility of the customer in all cases.

TOPMETER RETURN

BALANCING VALVE (RETURN)



Direct regulation, indication and isolation of flows from heating and cooling circuits in manifold return pipe bars.

DESCRIPTION

The TopMeter offers an easy and accurate method of adjusting flow rates. The underlying measuring principle requires that the flow has settled in order to ensure reliable indicator values.

No complicated flow adjustment is required on the return pipe TopMeter to achieve this. Rather, the medium allows ideal inflow from the upstream inlet pipe.

Correct balancing of hydraulic circuits ensures optimum energy distribution, resulting in more efficient and economical operation in accordance with the energy saving regulations provided for by legislation.

With TopMeters, any qualified fitter can set the appropriate flow rate on the premises in question, thus avoiding investments in training and costly measuring devices.

INSTALLATION POSITION

The TopMeter is installed in the return pipe bar of the manifold in a horizontal or vertical position. The adaptation of the manifold must correspond to the manufacturer's specifications in accordance with the mounting dimension drawings.

ADVANTAGES

- Precise and quick balancing without diagrams, tables or measuring devices
- Flow rate displayed directly in l/min
- Settings can be blocked with the 1/2" TopMeter and adjustments prevented using a lead seal
- Regulating valve with isolating facility
- Removable sight glass available as a replacement part
- Can be installed in any position

OPERATION

The flow measurement is based on the displacement principle of a baffle disc, which is inserted in a measuring tube. The position is conveyed to the sight glass on the indicator unit by means of a sliding bar, which fixes the baffle disc to the indicator unit. The scale printed on the sight glass allows the flow rate to be read with ease.

Turning the black spindle changes the opening profile of the valve and allows the desired flow rate to be set. The flow is isolated by turning the spindle fully.

BUILDING CATEGORIES

For installations in the heating and cooling area:

- Apartment blocks, housing estates, multiple dwelling units
- Residential care facilities, hospitals
- Administration and service buildings
- Hotels and restaurants, industrial kitchens
- School buildings and sports facilities
- Commercial and industrial buildings
- Facilities with partial use, such as barracks, camping sites

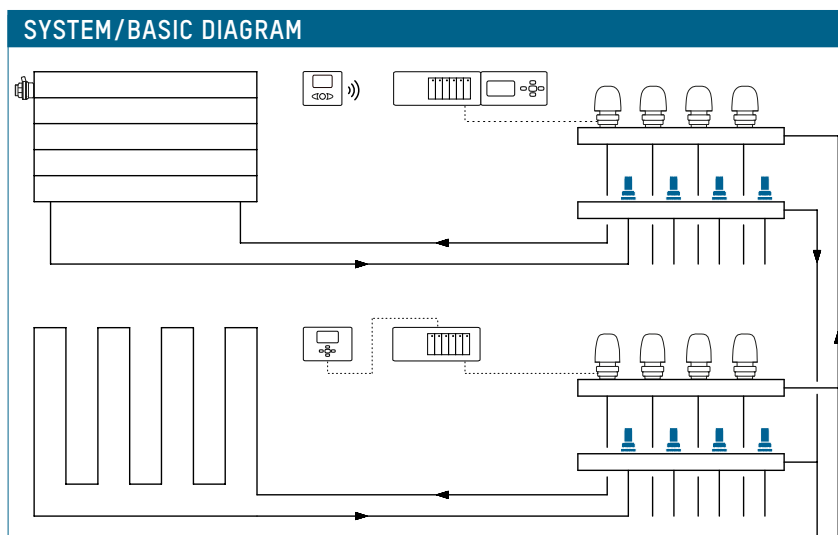

SPECIFICATION TEXT

See www.taconova.com

TECHNICAL DATA

General

- Medium temperature: -10 °C – +80 °C
- Operating pressure $P_{0,max}$: 6 bar
- Measuring accuracy: ± 10% of the highest nominal value (the change in viscosity must be taken into account with antifreeze additives)
- k_{VS} value and measuring range: see type overview
- External thread G (cylindrical) as per ISO 228

Material

- Brass, heat-resistant plastics and stainless steel
- Seals: EPDM

Fluids

- Heating water (VDI 2035; SWKI BT 102-01; ÖNORM H 5195-1)
- Water and proprietary additives used against corrosion and freezing up to 50%

ADDITIONAL MODELS

See data sheet for TopMeter Supply

ASSEMBLY

When assembling the TopMeter in the manifold, the tightening torque must not exceed 30 nM.

SERVICE

The sight glass can be removed if necessary for maintenance purposes and replaced. The relevant under-floor heating circuit must be separated in this case from the rest of the system. See installation instructions No. EA 1008.

TYPE OVERVIEW

TopMeter Return | Balancing valve - Return pipe

Order no.	DN	G	Measuring range	k_{VS} (m ³ /h)
223.5203.XXX	15	½"	0,6 – 2,4 l/min	1,2*
223.5204.XXX	15	½"	1,0 – 4,0 l/min	1,7*
223.5208.XXX	15	½"	2,0 – 8,0 l/min	2,4*
223.5215.XXX	15	½"	1,0 – 15,0 l/min	2,0*
223.5303.XXX	10	⅜"	0,5 – 2,5 l/min	0,8*
223.5304.XXX	10	⅜"	1,0 – 5,0 l/min	1,0*

* The effective k_{VS} value depends on the counterpart used and the manifold geometry. The definitive order number is assigned on the basis of the particular configuration.

DIMENSIONAL DRAWING

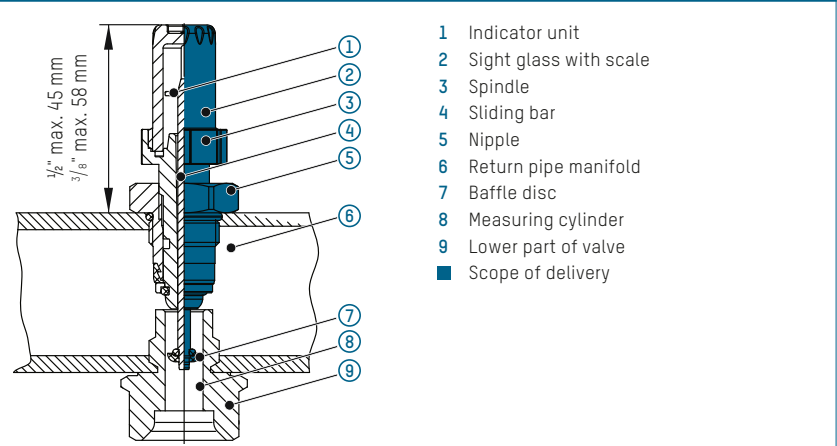

NOTE

Depending on the individual design of your application, the manifold (lower part of valve) has to be adapted to the TopMeter. We can provide you with a drawing for this purpose (construction data sheet). Please request our construction data sheet if you need it. The retaining O ring as well as the counterpart in the manifold are the responsibility of the customer in all cases.

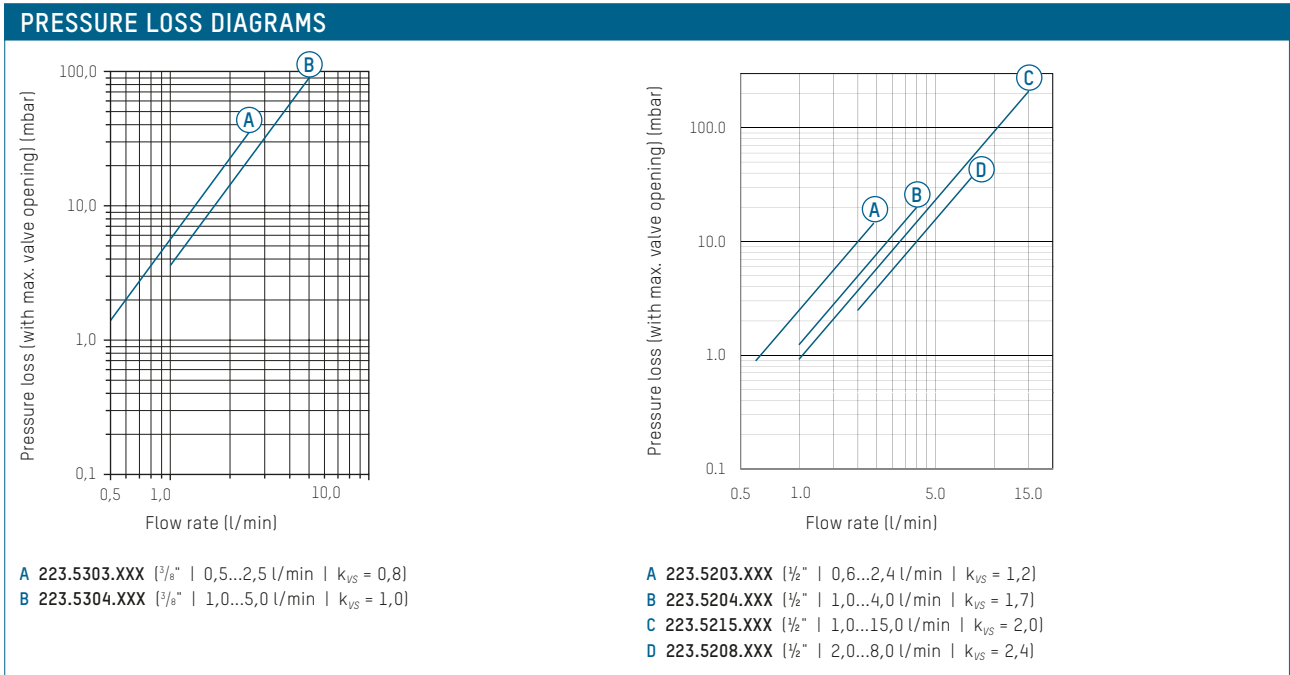

SPARE PARTS

Order no.	Sight glass 1/2"	Order no.	Sight glass 3/8"
298.2303.000	0,6 – 2,4 l/min	298.2313.000	0,5 – 2,5 l/min
298.2304.000	1,0 – 4,0 l/min	298.2314.000	1,0 – 5,0 l/min
298.2308.000	2,0 – 8,0 l/min		

PRECISE, DEMAND-BASED ENERGY DISTRIBUTION

One of the main functions demanded of heating and cooling systems is to ensure the right room temperature at the right time. Additional regulating components make it possible to achieve constant heating or cooling performance as and when needed.

INDIVIDUAL USE OF BUILDINGS

Depending on the type of use of the building, room heating or cooling must be tailored to the individual needs of users. These are influenced by:

- Irregular usage or occupancy times
- Higher heating or cooling requirements at specific times of the day, for example during the day in residential buildings or at weekends in commercial premises
- Loss of heat through opening doors or draughts
- Room temperature regulation for different zones

AUTOMATION BY MEANS OF ADDITIONAL COMPONENTS

In order to provide individual temperatures as and when needed, a heating or cooling system can be automated by adding more components.

This means that the use of the system can be controlled by means of actuators on the valves in combination with room thermostats, depending on programmed times and required temperatures.

In addition, distributors fitted with actuators also allow the system to be integrated in a building automation system. The TopMeter Plus with reproducible balancing function as well as the TacoDrive actuators with first-open function are already preinstalled in the latest product, the TacoSys Pro.

PERMANENT CONTROL

Room thermostats constantly monitor the room air temperature and compare it with the set target value. If the actual temperature drops below the target room temperature, the room thermostat sends a signal (via a connector module) to the actuator. This performs a silent lifting movement which is transmitted directly to the valve in the distributor bar, opening the heating circuit. This causes hot or cold liquid to flow into the circuit until the target temperature is reached and measured by the room thermostat. The latter sends a signal to the actuator, causing it to close the valve again.

QUICK AND EASY TO INSTALL. PERFECT TEAMWORK

The TacoDrive, TopDrive and NovaDrive actuators use the room thermostats to open or close the valve settings in the distributor bar on the basis of the required heat. The intermediate NovaMaster connector module allows a fixed line or wireless connection to be established between the actuators and room thermostats.

THE PERFECT COMPLEMENT FOR SYSTEMS ALREADY AVAILABLE ON THE MARKET

NovaDrive actuators are available for both open when off and closed when off operating modes, while TacoDrive and TopDrive are available only for closed when off mode. The actuators will fit almost all commercial valves and have bayonet or click-in connections for quick and easy installation.

CAN BE RETROFITTED USING WIRELESS TECHNOLOGY

Available in both wired and wireless versions: The basic version for controlling 230 V NC actuators will cover the most common applications. Other versions allow 230 V and 24 V NO actuators to be controlled, as well as drives with auxiliary switches or proportional lifting. In addition, Taconova also supplies wireless room thermostats. The use of wireless transmission technology means that there is no need for time-consuming cable laying – a major advantage when retrofitting a system and when working in new buildings.

MAXIMIZING ENERGY SAVINGS

A pump logic module can also be added to the controller; this switches off the pump when heating is no longer needed. This saves energy and protects the pump.

PERFECT CONTROL FOR SATISFIED CUSTOMERS

The valve actuators and room thermostats from Taconova efficiently automate the distribution of energy for panel heating and cooling systems as needed. The broad product range covers every price and performance bracket and offers the perfect solution for every need.

BENEFITS AT THE PLANNING STAGE

- Security thanks to customized and proven system solutions
- Reliable compliance with design temperatures
- Flexible installation options even in retrofitting projects because the actuators match all common valve types
- Easy retrofitting with wireless room thermostats
- Combination options and a range of extendable connector modules mean that complex requirements can be met

BENEFITS AT THE INSTALLATION STAGE

- Quick and easy installation of actuators by means of bayonet fittings
- Easy functional control of the actuators thanks to tactile and visual valve position guides
- Comfort thanks to constant room temperatures
- Long service life means no maintenance required

Actuators	
<p>The new TacoDrive actuator can already be found preinstalled in many panel heating manifolds (for example TacoSys Pro). Only the plug for the power supply has to be connected at startup. No complex assembly work is required. The completely pre-assembled TacoSys stainless steel manifolds are designed for two to twelve heating circuits. The equipment also includes, among other things, the TopMeter (TacoSys High End) and the TacoVent Vent.</p>	<ul style="list-style-type: none"> ▪ TacoDrive NC ▪ NovaDrive NC/NO ▪ TopDrive NC

Room thermostats	
<p>Taconova offers a wide range of room thermostats. These work perfectly with the NovaDrive and TopDrive actuators. For new construction and remediation, the cable (EL) and radio (RF) versions are recommended. The radio versions are also particularly suitable for renovation.</p>	<ul style="list-style-type: none"> ▪ NovaStat EL (Electronic) ▪ NovaStat RF (Radio Frequency)

Connecting modules	
<p>For complex room climate requirements in a building, the room thermostats can be combined with open-ended connecting modules.</p>	<ul style="list-style-type: none"> ▪ NovaMaster EL (Electronic) ▪ NovaMaster RF (Radio Frequency)

Heating and cooling energy generation	Heating and cooling energy distribution (room climate)	Sanitary systems
–	<ul style="list-style-type: none"> ▪ Underfloor heating ▪ Radiators ▪ Chilled and heated ceilings ▪ Fan coils and chill beams ▪ Concrete cores 	–

TACODRIVE

THERMAL ACTUATOR WITH MANIFOLD VALVE



Electro-thermal actuator in normally closed mode for installation in panel heating manifolds.

DESCRIPTION

TacoDrive is a valve drive unit consisting of an electro-thermal actuator and a heating valve. The valve drive unit is intended for installation in panel heating manifolds.

The innovative valve technology is compatible with the standardized Taconova TopMeter interface. This patented technology allows the actuator to be designed in a compact manner.

The valve drive unit has been reduced to the essential functional components and is especially suitable for automatic installation in panel heating manifolds. The integrated and reversible first-open function guarantees the subsequent filling and venting of the system. The system operator can use the integrated valve position indicator to check the actual valve position.

ADVANTAGES

- Extremely compact
- Pre-assembled valve drive unit for automatic installation in panel heating manifolds
- Actuator with connector and maximum protection class (IP54)
- Integrated valve position indicator
- Integrated reversible first-open function for manual operation
- Can be adapted to TopMeter interface
- Very high valve control force owing to direct-acting expansion element

INSTALLATION POSITION

In the panel heating manifold return bar. The IP54 protection class allows subsequent installation of the heating manifold in any installed position.

OPERATION

The TacoDrive combines valve and actuator for controlling heating circuits at panel heating manifolds. The valve drive unit operates in normally closed (NC) mode. The TacoDrive is activated by a room temperature control unit (e.g. in the NovaStat series) with a two-step output.

BUILDING CATEGORIES

For installation in heating and cooling applications in:

- Apartment blocks, housing estates, multiple dwelling units
- Residential care facilities and hospitals
- Administration and service buildings
- Hotels and restaurants
- School buildings and sports halls, sports facilities
- Commercial and industrial buildings
- Facilities with partial use – for example, barracks, camping sites etc.



TECHNICAL DATA

Actuator

- Type: Normally closed (NC)
- Ambient temperature: 0 - 50 °C
- Opening/closing time: approx. 3 minutes
- Visual inspection of expansion element
- Reversible first-open
- Protection class of actuator: IP54
- Protection class II

Electrical connection data

- Rated voltage. 230 V, 50/60 Hz
- Permissible voltage deviation: ±10%
- Operating efficiency: 1.8 W
- Inrush current: 230 V: 0.6 A for max. 100 ms
- Recommended fuse: 0.35 A slow-acting, as per DIN 41662
- Connection cable length: 1 m
- Connection cable: 2 * 0.75 mm², PVC with plug protected against polarity reversal

Valve

- Medium temperature: -10 °C - +60 °C
- Operating pressure P_{0 max}: 6 bar
- System test pressure: max. 10 bar (20 °C)
- k_{vs} value: 1.55
- External thread G 1/2" (cylindrical) as per ISO 228
- Double valve stem seal with grease reservoir
- Visual inspection of valve

Material

- Brass, heat-resistant plastics
- Seals: EPDM, FKM

Fluids

- Heating water (VDI 2035; SWKI BT 102-01; ÖNORM H 5195-1)
- Cooling water and water mixtures with typical corrosion and anti-frost additives

APPROVALS / CERTIFICATES

- VDE

TYPE OVERVIEW

TacoDrive | Electro-thermal actuator, NC (Normally Closed) mode, suitable for valves of Taconova

Order no.	Fixing	Nipple
259.2270.000	G 1/2"	Brass
259.2270.100	G 1/2"	Brass, nickel-plated

* The required valve bottom section depends on the cross-section of the manifold bar used and has to be agreed with Taconova.

DIMENSIONAL DRAWING

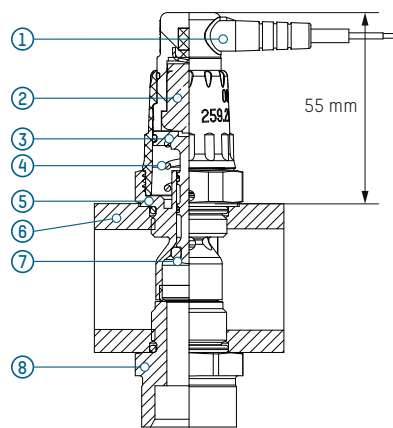

- 1 Mains connection
- 2 Expansion element with PTC
- 3 Valve spindle with valve position indicator
- 4 Valve spring
- 5 Brass nipple for valve assembly
- 6 Return manifold bar *
- 7 Valve disk
- 8 Valve bottom section *

* Valve bottom section and manifold bars are not included in the scope of delivery

PRESSURE LOSS DIAGRAM

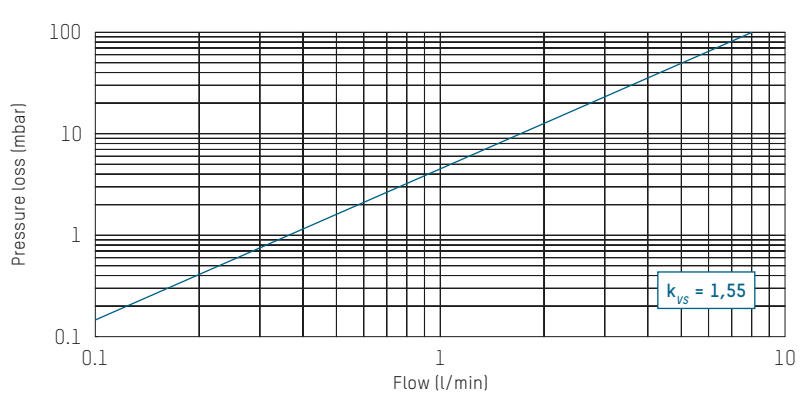

NOTE
PTC patent application
CH2015/000054

OPERATING MODES

Valve open,
first open engaged

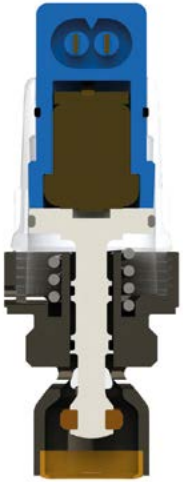

Valve open,
operating function

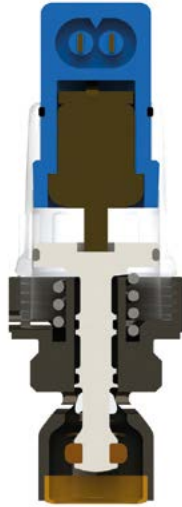

Valve closed,
standby

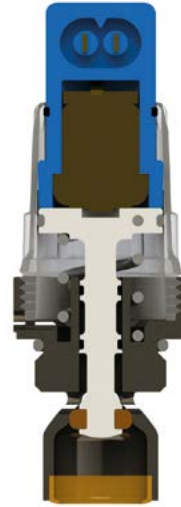

Splash-proof based on O-rings

CIRCUIT DIAGRAM

- 1 Voltage on
- 2 Dwell time on
- 3 Voltage off
- 4 Dwell time off

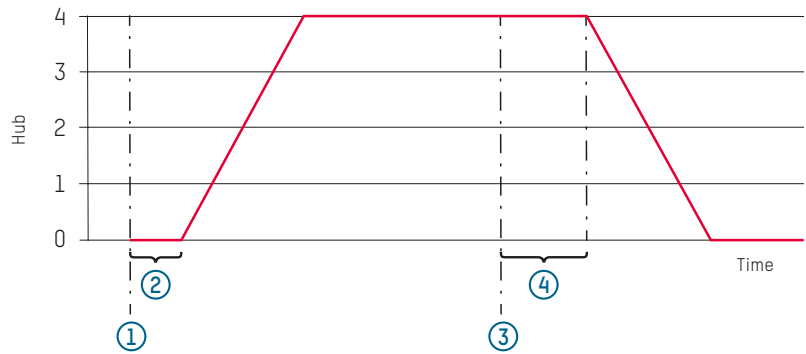

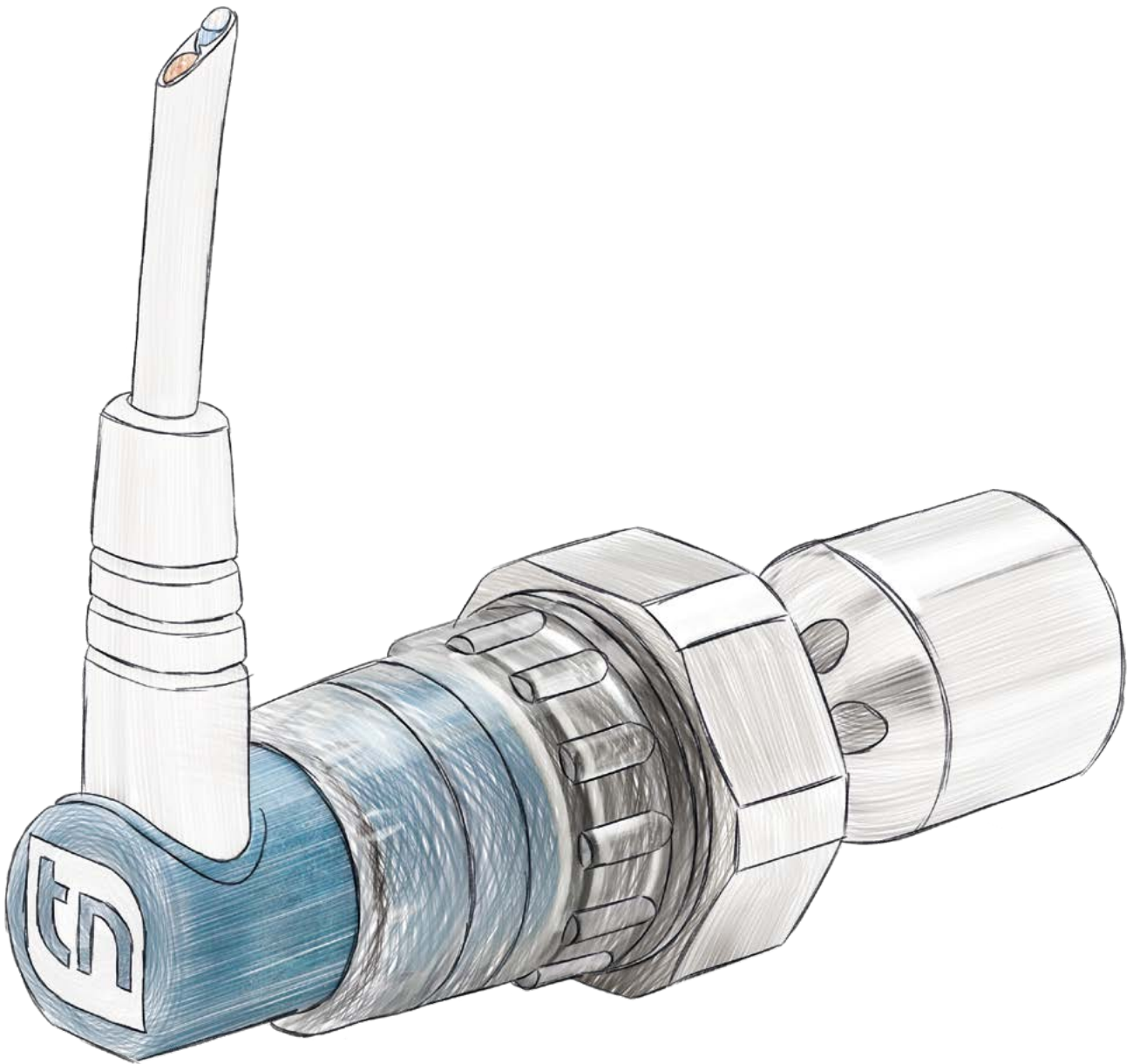

NOVADRIVE NC/NO

ACTUATOR



Electro-thermal actuators in the operating mode normally open and normally closed for heating circuit manifolds and radiator valves.

DESCRIPTION

NovaDrive NC/NO actuators in the new, attractive appearance used in conjunction with room thermostats, time switches and building automation systems offer an efficient means of controlling temperatures in heating and cooling systems to suit individual requirements. Thanks to the operating mode NO (normally open) and NC (normally closed) as well as the quick-locking, large surface bayonet connection, the actuators can be used in a wide range of applications in all HVAC systems.

These actuators can help eliminate energy wastage in heating as well as in cooling and offer the ideal solution for energy control in buildings with irregular occupancy levels. Typical installations include apartments, offices, schools, hotels etc. The standard valve position indicators integrated into the actuators control the system functions during the assembly, commissioning and monitoring stages.

INSTALLATION POSITION

Any.

ADVANTAGES

- Operating mode NO normally open and NC normally closed
- Valve position visually indicated and tangible
- Bayonet connection audibly engaged with click
- Attractive appearance
- Low power input
- Silent operation
- Available to fit most valve bodies
- Connection cable, pluggable

OPERATION

An electrical resistance heats an expansion element. Any deviation from the nominal room temperature value causes the actuator to transmit an appropriate stroke movement to the valve. The thermostat and actuator operate according to the «ON / OFF» principle. The variable, rhythmic opening and closing, depending on the heat demand, also produces an almost continuous control characteristic. In the without current state, the valve is open with the type NO and closed with the type NC.

BUILDING CATEGORIES

For installations in the heating and cooling area:

- Apartment blocks, housing estates, multiple dwelling units
- Residential care facilities, hospitals
- Administration and service buildings
- Hotels and restaurants, industrial kitchens
- School buildings and sports facilities
- Commercial and industrial buildings

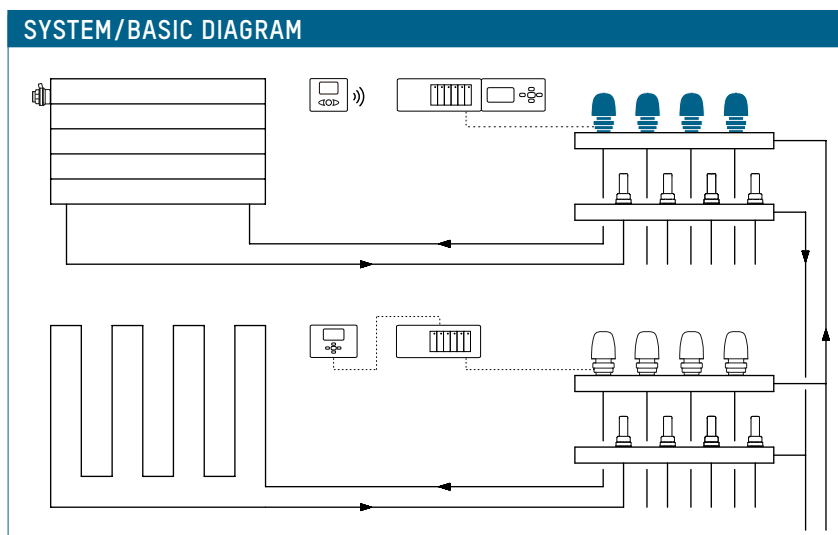

SPECIFICATION TEXT

 See www.taconova.com
TECHNICAL DATA
General

- Versions:
 - Normally closed NC
 - Normally open NO
- Ambient temperature: 0 ... 50° C
- Opening /closing time: approx. 3 min.
- Nominal stroke: 4 mm
- Nominal closing force 90 N
- Protection mode IP 40
- Protection class II

Electrical specifications

- Rated voltage (AC or DC):
24 V or 230 V
- Permissible voltage deviation:
±10%
- Operating efficiency: 1.6 W
- Inrush current:
 - 24V: 0.2 A for max. 1 min;
 - 230V: 0.6 A for max. 100 ms
- Recommended fuse protection:
0.35 A time delay, according to
DIN 41662
- Connecting cable length 1 m

APPROVALS / CERTIFICATES

- CE conformity symbol
- The technical data conforms with
the respective EN standards

ACCESSORIES

Various room thermostats and junction modules for wired and wireless applications (see separate data sheets).

TYPE OVERVIEW

NovaDrive NC | Electro-Thermal Actuator, Function NC (Normally Closed)

Order no. 230 V	Connection	Suitable for valves of make*
257.2854.000	M30 × 1,0	Beulco (old type, approx. until march 2005)
257.2855.000	M30 × 1,5	TacoSys/Heimeier/Strawa/Empur Messing/Oventrop/Delphistherm/ Emmeti/Schlösser/Beulco/AC-FIX/ Stramax/Roth/IVR
257.2858.000	M28 × 1,5	Herz (RV 57)
257.2862.000	M30 × 1,5	MNG/Cazzaniga/SBK/Empur-Edelstahl/ SKV-Ventil frontal
257.2864.000	Adapter	Giacomini
257.2880.000	M30 × 1,5	Viega

Order no. 24 V	Connection	Suitable for valves of make*
257.1854.000	M30 × 1,0	Beulco (old type, approx. until march 2005)
257.1855.000	M30 × 1,5	TacoSys/Heimeier/Strawa/Empur Messing/Oventrop/Delphistherm/ Emmeti/Schlösser/Beulco/AC-FIX/ Stramax/Roth/IVR

NovaDrive NO | Electro-Thermal Actuator, Function NC (Normally Open)

Order no. 230 V	Connection	Suitable for valves of make*
257.2554.000	M30 × 1,0	Beulco (old type, approx. until march 2005)
257.2555.000	M30 × 1,5	TacoSys/Heimeier/Strawa/Empur Messing/Oventrop/Delphistherm/ Emmeti/Schlösser/Beulco/AC-FIX/ Stramax/Roth/IVR
257.2562.000	M30 × 1,5	MNG/Cazzaniga/SBK/Empur-Edelstahl/ SKV-Ventil frontal
257.2564.000	Adapter	Giacomini

Order no. 24 V	Connection	Suitable for valves of make*
257.1554.000	M30 × 1,0	Beulco (old type, approx. until march 2005)
257.1555.000	M30 × 1,5	TacoSys/Heimeier/Strawa/Empur Messing/Oventrop/Delphistherm/ Emmeti/Schlösser/Beulco/AC-FIX/ Stramax/Roth/IVR
257.1562.000	M30 × 1,5	MNG/Cazzaniga/SBK/Empur-Edelstahl/ SKV-Ventil frontal

*Further specific customer designs for all types of valve bodies on request.
If you are unsure about valve adjustment, please contact customer service.

ECO-TIP

SAVE ENERGY AND MONEY!

To avoid unnecessary hours of operation, the actuator should be switched off via the room thermostat out of the heating period.

DIMENSIONAL DRAWING

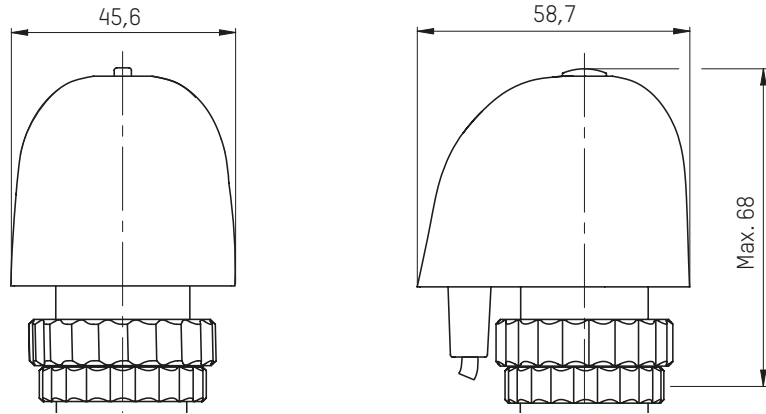

OPERATING MODES

Assembled state without current:

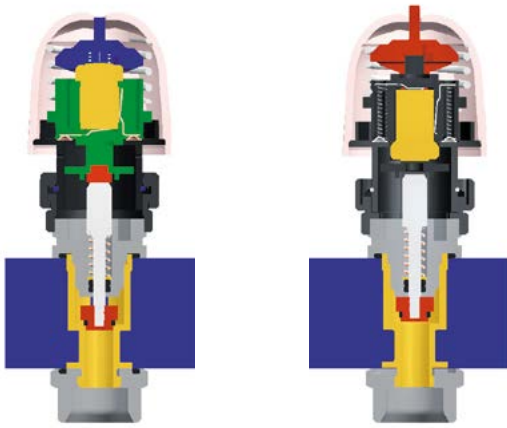

Type NC: Valve closed

Type NO: Valve open

Operated state under current:



Type NC: Valve open

Type NO: Valve closed

CIRCUIT DIAGRAMS

Normally Closed (NC)

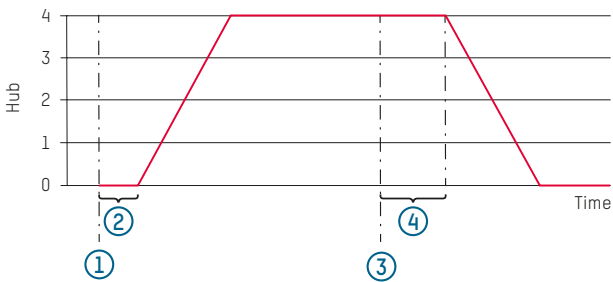

- 1 Voltage on
- 2 Dwell time on
- 3 Voltage off
- 4 Dwell time off

Normally Open (NO)

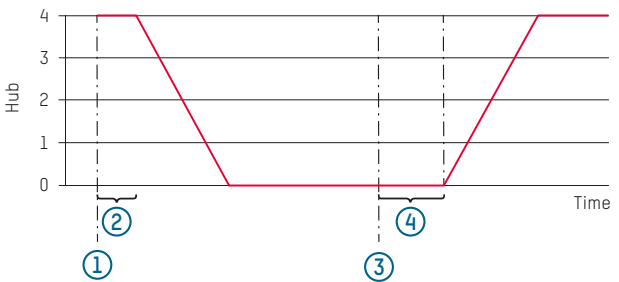

TOPDRIVE

ACTUATOR



Electro-thermal actuators in the operating mode normally closed for heating circuit manifolds and radiator valves.

DESCRIPTION

TopDrive actuators in the new, great design used in conjunction with room thermostats, time switches and building automation systems offer an efficient means of controlling temperatures in heating and cooling systems to suit individual requirements.

The normally closed (NC) operating mode, the easily and quickly fitted bayonet connection and the possibility of overhead installation (360° installation) ensure that the TopDrive actuators can be used for versatile applications in heating, ventilation, air conditioning and sanitary systems.

Homes, offices, schools, hotels, etc. are typical examples of properties with high saving potential, since heating and cooling systems are consistently used only as and when required.

Internal visual indication of valve position is standard and serves as a functional control feature during installation, commissioning and monitoring.

INSTALLATION POSITION

360° installation

ADVANTAGES

- Protection against leaking valves
- Protection rating actuator IP 44, CE
- 360° installation
- Compatible to most valve bodies
- Valve position visually indicated and tangible
- Easy installation through bayonet connector

OPERATION

An electric resistance heats an expansion element. Any deviation from the nominal room temperature value triggers the actuator to transmit an appropriate stroke movement to the valve.

The thermostat and actuator operate according to the «ON / OFF» principle. The variable, rhythmic opening and closing, depending on the heat demand, also produces an almost continuous control characteristic. The valve is normally closed.

BUILDING CATEGORIES

For installations in the heating and cooling area:

- Apartment blocks, housing estates, multiple dwelling units
- Residential care facilities, hospitals
- Administration and service buildings
- Hotels and restaurants, industrial kitchens
- School buildings and sports facilities
- Commercial and industrial buildings

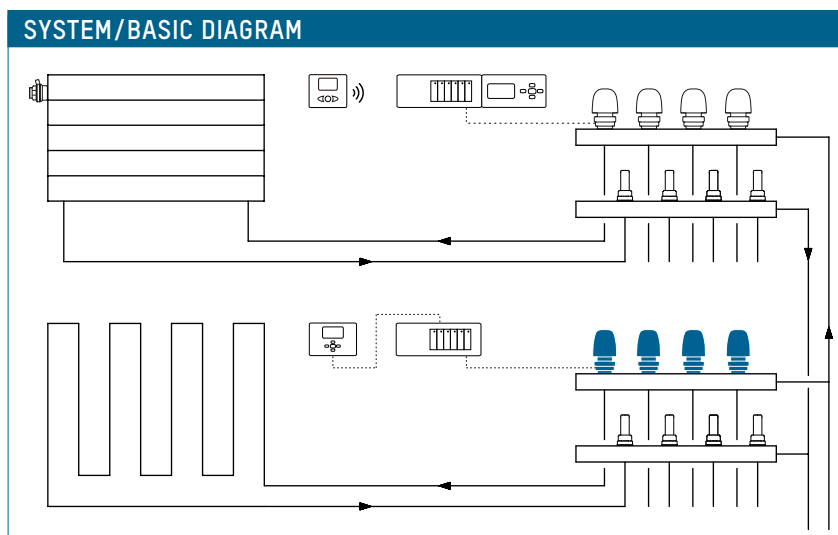

SPECIFICATION TEXT

See www.taconova.com

TECHNICAL DATA

General

- Type: Normally closed (NC)
- Ambient temperature: 0 ... 60°C
- Opening/closing time: Approx. 3 Min.
- Hub: 4 mm
- Nominal closing force: 100 N ± 7%
- Protection type: IP 44
- Electrical protection class II

Electric connection data

- Operating voltage (AC or DC): 24 V or 230 V
- Permissible voltage deviation: ±10%
- Operating efficiency: 1.6 W
- Inrush current:
 - 24V: 0.2 A for max. 1 min
 - 230V: 0.6 A for max. 100 ms
- Recommended fuse protection: 0,35 A time delay, according to DIN 41662
- Connecting cable length: 1 m
- Connection cable: 2 × 0.75 mm², PVC

APPROVALS / CERTIFICATES

- CE conformity symbol
- The technical data conforms with the respective EN standards

ACCESSORIES

Various room thermostats and junction modules for wired and wireless applications (see separate data sheets).

ECO-TIP

SAVE ENERGY AND MONEY!

To avoid unnecessary hours of operation, the actuator should be switched off via the room thermostat out of the heating period.

TYPE OVERVIEW

TopDrive | Electro-Thermal Actuator, Function NC (Normally Closed)

Order no. 230 V	Connection	Suitable for valves of make*
257.2055.000	M30 × 1,5	TacoSys/Heimeier/Strawa/Empur Messing/Oventrop/Delphistherm/Emmeti/Schlösser/Beulco/AC-FIX/Stramax/Roth/IVR
257.2058.000	M28 × 1,5	Herz (RV 57)
257.2062.000	M30 × 1,5	MNG/Cazzaniga/SBK/Empur-Edelstahl/SKV-Ventil frontal
257.2064.000	Adapter	Giacomini

Order no. 24 V	Connection	Suitable for valves of make*
257.1055.000	M30 × 1,5	TacoSys/Heimeier/Strawa/Empur Messing/Oventrop/Delphistherm/Emmeti/Schlösser/Beulco/AC-FIX/Stramax/Roth/IVR
257.1058.000	M28 × 1,5	Herz (RV 57)
257.1062.000	M30 × 1,5	MNG/Cazzaniga/SBK/Empur-Edelstahl/SKV-Ventil frontal
257.1064.000	Adapter	Giacomini

* Further specific customer designs for all types of valve bodies on request.
If you are unsure about valve adjustment, please contact customer service.

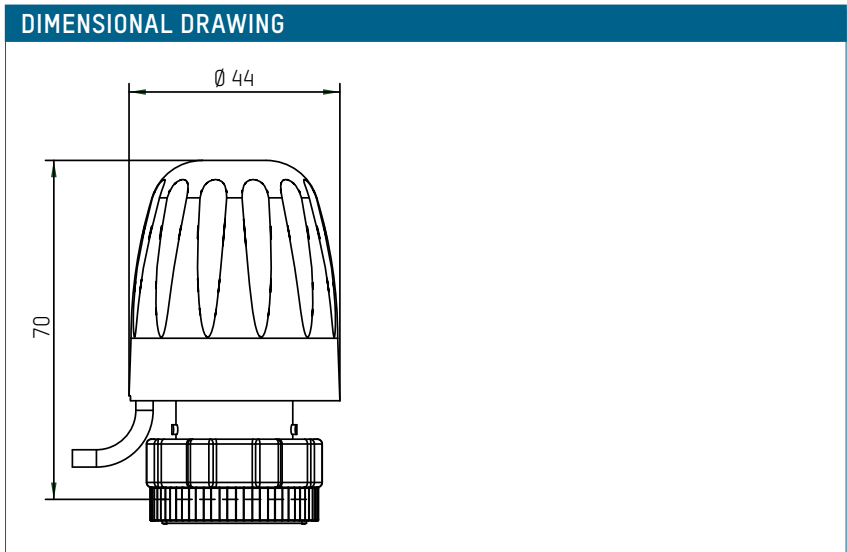

OPERATING MODES

Valve closed (no electric current)

Valve open (energised)

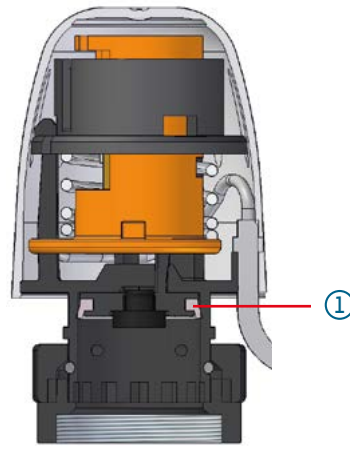
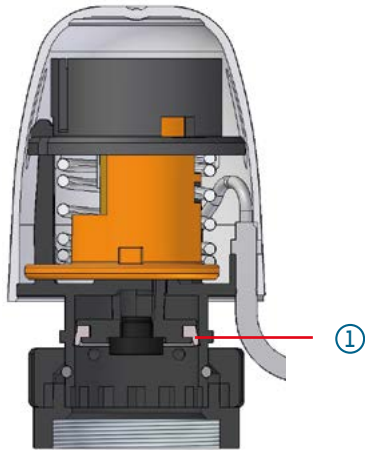

1 Water protection by means of form seal

BAYONET CONNECTION

Bayonet connection with four large interlocking faces between bayonet sleeve and nut

- 1 Bayonet sleeve
- 2 Threaded bayonet-nut
- 3 Large contact surface
- 4 Turn until audible click

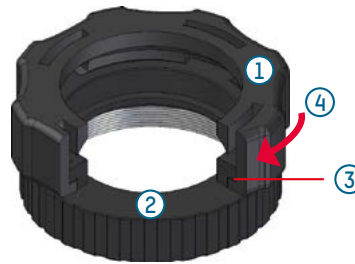

CIRCUIT DIAGRAMS

- 1 Voltage on
- 2 Dwell time on
- 3 Voltage off
- 4 Dwell time off

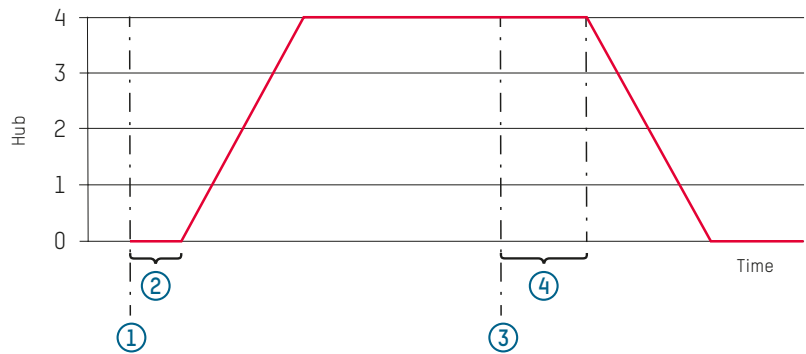

NOVASTAT / NOVAMASTER EL

ELECTRONIC ROOM THERMOSTATS AND CONNECTOR MODULES



ADVANTAGES

- Easy to operate
- Noiseless Triac circuit
- Units for 230 V and 24 V power supply
- Integrated derivative action control or PI control (adjustable)
- Simple wiring through the NovaMaster EL Basic, Logic and SlaveBox terminal modules

Individual control of room temperature.

DESCRIPTION

Room thermostats in combination with Taconova NovaDrive or TopDrive actuators provide a constant room temperature in closed and dry rooms. The Taconova room thermostat range, classified according to price/performance, offers the correct solution for individual needs.

The basic version **NovaStat EL Basic** for the control of 230 V NC actuators covers the most common application range.

The **NovaStat EL Digital 2** version displays the set and actual values on a digital display.

Individual heat regulation as required by the operator is achieved by means of the programmable digital **NovaStat EL Week** clock thermostat. The time duration of the lowering mode can be set in the week program by means of the integral timer.

The connection of the room thermostats to the terminal module **NovaMaster EL Basic and/or Logic** is simple and uncomplicated.

Further convenient settings are possible by mean of the optional plug-in **NovaMaster EL Timer**.

INSTALLATION POSITION

The thermostats are mounted in the respective room while the connector modules are mounted close to the manifold.

OPERATION

By means of an NTC sensor element, the downstream PI or derivative action controller, the room thermostats provide a constant room temperature in combination with actuators. Switching is via a silent TRIAC element or a floating relay. Control is by means of the actuator acting on the valve according to the OPEN / CLOSED principle. The PI or derivative action controller integrated into the room thermostat prevents the room temperature from exceeding the desired value set on the room thermostat.

BUILDING CATEGORIES

For installations in the heating and cooling area:

- Apartment blocks, housing estates, multiple dwelling units
- Residential care facilities, hospitals
- Administration and service buildings
- Hotels and restaurants, industrial kitchens
- School buildings and sports facilities
- Commercial and industrial buildings

SYSTEM/BASIC DIAGRAM

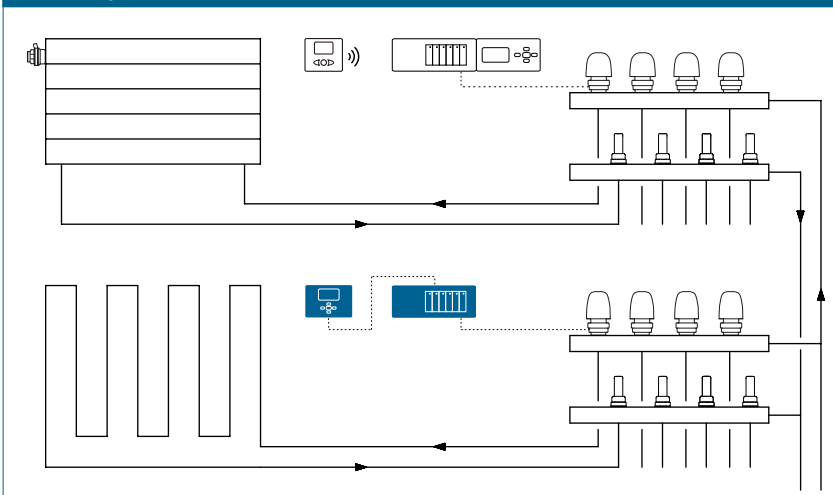



1 NOVASTAT EL BASIC

Room thermostat for normally closed actuators

230 V room thermostat for controlling NC actuators for underfloor heating systems. Noiseless switching output (Triac) with direct or indirect connection of actuators. Dial with integral adjustment facility for correction of actual temperature integrated into the dial.

TECHNICAL DATA

- Order no.: 206.1650.000
- Operating voltage: 230 VAC 50 Hz \pm 10 %
- Operating temperature: 0–50 °C (32–122 °F)
- Adjustment range: 5–30 °C (41–86 °F)
- Switching output: TRIAC 230 VAC, NC max. 75 W
- Type of protection: IP 30, Protection class II
- Type of controller: Static derivative action controller
- Differential gap: \pm 0,5K
- Temperature sensor: NTC 100 K
- Dimensions / color: H80 \times W80 \times D31 mm / RAL 9010
- Version without handwheel (NovaStat EL Public, 230 V + 24 V) on request

2 NOVASTAT EL INWALL

Room thermostat for normally closed actuators

Electronic 230 V flush-mounted room thermostat for controlling NC actuators for underfloor heating systems. Relay switching output with direct or indirect connection of actuators. An external timer switch or an additional floor sensor can be fitted. Mode can be set by mean of jumpers.

TECHNICAL DATA

- Order no.: 206.1654.000
- Operating voltage: 230 VAC 50 Hz \pm 10 % / 5 VA
- Operating temperature: 0–50 °C (32–122 °F)
- Adjustment range: 5–35 °C (41–86 °F)
- Switching output: Relais 230 VAC / max. 16 A
- Type of protection: IP 21, Protection class II
- Type of controller : Two point control
- Sensor deviation: \pm 1 K
- Hysteresis: 0.75 °C
- Temperature sensor: NTC 10 K
- Frame dimensions: Standard 65 mm

3 NOVASTAT EL DIGITAL 2

Room thermostat for normally closed and normally open actuators

Electronic, battery-operated room thermostat for operating NC/NO actuators, for underfloor heating systems with digital display. Floating relay output for direct or indirect connection of 24 V/230 V actuators. With normal, reduced temperature or frost protection settings. Timer function for temperature reduction or increase. Battery charge status indicator on the display. Keypad lock function. Input for external temperature sensor (NTC 10 K).

TECHNICAL DATA

- Order no.: 206.1660.000
- Operating voltage: 2 \times LR6 AAA 1,5 V batteries
- Operating temperature: 0–40 °C (32–104 °F)
- Adjustment range: 5–35 °C in 0,5 °C steps (41–95 °F)
- Switching output: 3 A (250 VAC)
- Type of protection: IP 30, Protection class II
- Type of controller : Static differential action or PWM (proportional)
- Differential gap: \pm 0,5 K
- Temperature sensor: NTC 10 K, optionally external NTC 10 K
- Dimensions / color: H 83 \times W 80 \times D 27 mm / RAL 9010

4 NOVASTAT EL WEEK

Room thermostat for normally closed and normally open actuators

Electronic battery operated and programmable room thermostat for controlling NC / NO actuators, for underfloor heating systems with digital display, floating relay output for direct or indirect connection of 24V / 230V actuators. Mode switch for normal and lowering mode or automatic timed programs. Can be programmed for weekly and daily programs and for vacations, frost protection and keyboard lock function. Battery supply to avoid data loss in the event of power failure. Battery charge state shown on the display.

TECHNICAL DATA

- Order no.: 206.1653.000
- Operating voltage: 2 × LR6 AA 1,5 V batteries
- Operating temperature: 0–50 °C (32–122 °F)
- Adjustment range: 5–35 °C (41–95 °F) frost protection 0,5–10 °C (33–50 °F)
- Switching output: Relais floating, NC / NO max. 8 A
- Type of protection: IP 30, Protection class II
- Type of controller: PI controller
- Adjustment bandwidth: 2 °K of proportional band
- Adjustment speed: 7,5 cycles / hour (8 min cycle)
- Temperature sensor: NTC 100 K
- Dimensions / color: H 86 × B 125 × T 32 mm / RAL 9010

NOVAMASTER EL | ELECTRONIC CONNECTOR MODULES



1 NOVAMASTER EL BASIC

Wiring module for connecting electrothermal actuators and room thermostats with terminals marked by symbols

Modular design enables expansion by SlaveBox to provide for further connections. Direct wall mounting or mounting on DIN rail. Control of 24V actuators by means of optional transformer. Operating status output shown by LEDs

TECHNICAL DATA

- Order no.: 258.9310.000
- Operating voltage: 230 VAC 50 Hz ± 10 % / 24VAC with transformer
- Operating temperature: 0–50 °C (32–122 °F)
- Number of zones: 6 (max. 4 drives / zones)
- Max. number of drives: 24 × 230 VAC or 18 × 24VAC
- Number of drives / zones: Max. 4 drives / zones
- Time control line: None
- Type of protection: Protection class II IP 30
- Dimensions / color: H88 × B225 × T58 mm / RAL 9010

2 NOVAMASTER EL LOGIC

Wiring module for connecting electroterminal actuators and room thermostats with terminals marked by symbols.

Modular design enables expansion by NovaMaster EL Timer to provide for further control functions. Switching output for time control of room thermostat.

Two floating switching outputs as a control contact for pump logic.

Direct wall mounting or mounting on DIN rail. Operating status indicated by LEDs.

TECHNICAL DATA

- Order no.: 258.9311.000
- Operating voltage: 230 VAC 50 Hz ± 10 %
- Operating temperature: 0–50 °C (32–122 °F)
- Number of zones: 6 (max. 4 drives / zones)
- Max. number of drives: 24 × 230 VAC
- Time control line: Zones A and B present
- Switching output: 2 x relays, floating, max. 8 A
- Type of protection: Protection class II IP 30
- Dimensions / color: H88 × B225 × T58 mm / RAL 9010

3 NOVAMASTER EL SLAVEBOX

An expansion module for wiring electrothermal actuators and room thermostats with terminals marked by symbols

Plug-in expansion to NovaMaster EL Basic for further connection possibilities. Direct wall mounting or mounting on DIN rail. Control of 24V actuators by means of optional transformer. Operating status indicated by LEDs.

TECHNICAL DATA

- Order no.: 258.9313.000
- Operating voltage: 24 VAC with transformer / 230 VAC 50 Hz \pm 10 %
- Operating temperature: 0–50 °C (32–122 °F)
- Number of zones: 4 (max. 4 drives / zones)
- Max. number of drives: Σ NovaMaster EL Basic + SlaveBox = 24 \times 230 VAC oder 18 \times 24 VAC
- Time control line: None
- Type of protection: Protection class II IP 30
- Dimensions / color: H88 \times W160 \times D58 mm / RAL 9010

4 NOVAMASTER EL TIMER

NovaMaster EL Timer expansion module for connection to NovaMaster EL Logic

Programmable timer function for two time group A and B. Integrated application program of which nine are fixed and two are user programmable. Intelligent processor. Digital display for program, time and function display. Direct wall mounting or mounting on DIN rail.

TECHNICAL DATA

- Order no.: 258.9315.000
- Operating voltage: 230 VAC 50 Hz \pm 10 %
- Operating temperature: 0–50 °C (32–122 °F)
- Number of zones: 12 Zones, controllable
- Time control line: Zones A and B present
- Operating modes: Automatic; convenience; lowering
- Keyboard lock: Present
- Type of protection: Protection class II IP 30
- Dimensions / color: H88 \times W160 \times D62 mm / RAL 9010

5 TRANSFORMATOR

Transformer for connection to NovaMaster EL Basic or SB

Enables 24V actuators to be connected to the respective terminal module.

TECHNICAL DATA

- Order no.: 258.9316.500
- Operating voltage: 230 VAC 50 Hz \pm 10%
- Operating temperature: 0–50 °C (32–122 °F)
- Output voltage: 24 VAC max. 60 W
- Type of protection: Protection class II IP 30
- Dimensions / color: H83 \times W110 \times D61 mm / RAL 9010

NOVASTAT / NOVAMASTER RF

WIRELESS ROOM THERMOSTATS AND CONNECTOR MODULES



ADVANTAGES

- No wiring effort required
- Optimum positioning within the room
- Own signal encryption for unique assignment of room thermostat
- Simple connection of the actuators to the wiring module
- For actuators normally closed (NC) and normally open (NO)
- Intelligent processor

Individual control of room temperature.

DESCRIPTION

Room thermostats in combination with Taconova NovaDrive or TopDrive actuators provide a constant room temperature in enclosed and dry rooms.

The room thermostat range, classified according to price/performance, offers the correct solution for individual needs.

The basic version **NovaStat RF Basic** covers the most common range of applications.

The **NovaStat RF Digital** and **NovaStat RF Week** versions display the set and actual values on a digital display. Individual regulation of temperature in individual rooms as required by the operator is achieved by means of the

programmable digital **NovaStat RF Week** clock thermostat or the **NovaMaster RF Logic**. The time duration of the lowering mode can be set in the week program by means of the integral timer.

The individual room thermostats can be assigned to the **NovaMaster RF Logic** receiver module or the **NovaMaster RF Mini** single-channel receiver simply and without complicated wiring.

The connection options for actuators can be expanded with the optional pluggable **NovaMaster RF SlaveBox** module.

INSTALLATION POSITION

The thermostats are mounted in the respective room while the connector modules are mounted close to the manifold.

OPERATION

By means of an NTC sensor element, the downstream PI or derivative action controller, the room thermostats provide a constant room temperature in combination with actuators.

The control signal is transmitted to the central receiver by radio (868 MHz).

Control is by means of the actuator acting on the valve according to the OPEN/CLOSED principle.

The PI or derivative action controller integrated into the room thermostat prevents the room temperature exceeding the desired value set on the room thermostat.

BUILDING CATEGORIES

For installations in the heating and cooling area:

- Apartment blocks, housing estates, multiple dwelling units
- Residential care facilities, hospitals
- Administration and service buildings
- Hotels and restaurants, industrial kitchens
- School buildings and sports facilities
- Commercial and industrial buildings

SYSTEM/BASIC DIAGRAM

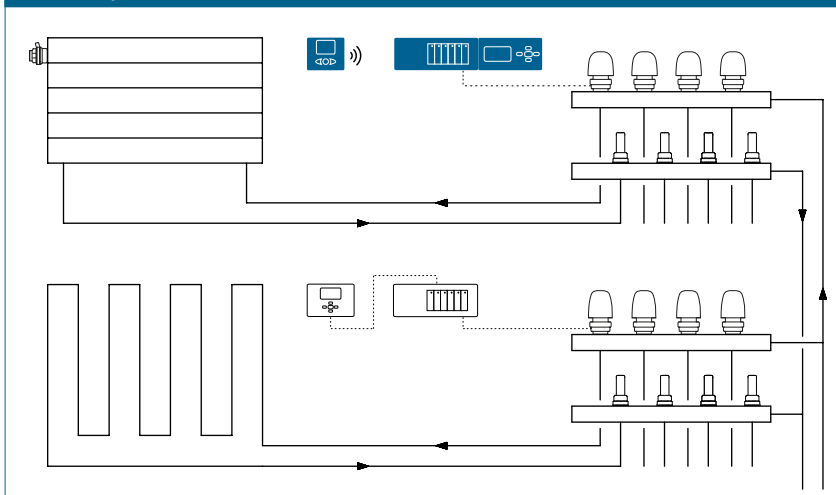



1 NOVASTAT RF BASIC

Electronic wireless room thermostat for indirect controlling of NC/NO actuators in underfloor heating systems

Desired values transmitted by radio signal (868 MHz). Each thermostat has its own signal encryption for unique assignment. Correction of the actual temperature is integrated into the adjustment dial.

TECHNICAL DATA

- Order no.: 206.1656.000
- Operating voltage: 2 batteries LRG AAA 1,5 V
- Operating temperature: 0–50 °C (32–122 °F)
- Adjustment range: 5–30 °C (41–86 °F)
- Radio frequency: 868 MHz, < 10 mW
- Certification: CE.EN 300220-1, EN 301489-1
- Type of protection: Protection class II IP 30
- Control behavior: Proportional band 2° K (15 min.)
- Temperature sensor: NTC 100 K
- Dimensions: H80 × W80 × D31 mm
- Color: RAL 9010

2 NOVASTAT RF DIGITAL

Electronic wireless room thermostat with digital display for indirect controlling of NC/NO actuators in underfloor heating systems

Desired values transmitted by radio signal (868 MHz). Each thermostat has its own signal encryption for unique assignment. Mode switch for normal and lowering modes. Further userdefined settings possible in system parameter menu.

TECHNICAL DATA

- Order no.: 206.1657.000
- Operating voltage: 2 batteries LRG AAA 1,5 V
- Operating temperature: 0–50 °C (32–122 °F)
- Adjustment range: 5–30 °C (41–86 °F)
- Radio frequency: 868 MHz, < 10 mW
- Certification: CE.EN 300220-1, EN 301489-1
- Type of protection: Protection class II IP 30
- Control behavior: PI controller or static derivative action controller, adjustable
- Temperature sensor: NTC 100 K
- Dimensions: H80 × W80 × D31 mm
- Color: RAL 9010

3 NOVASTAT RF WEEK

Electronic wireless room thermostat with digital display for indirect controlling of NC/NO actuators in underfloor heating systems.

Desired values transmitted by radio signal (868 MHz). Each thermostat has its own signal encryption for unique assignment. Mode switch for normal and lowering mode or automatic timed programs. Can be programmed for weekly and daily programs and for vacations, frost protection and keyboard lock function. Further user-defined settings possible in system parameter menu.

TECHNICAL DATA

- Order no.: 206.1658.000
- Operating voltage: 3 batteries LR6 AA 1,5 V
- Operating temperature: 0–50 °C (32–122 °F)
- Adjustment range: 5–35 °C (41–95 °F) Frost protection 0,5–10 °C (33–50 °F)
- Radio frequency: 868 MHz, < 10 mW
- Certification: CE.EN 300220-1, EN 301489-1
- Type of protection: Protection class II IP 30
- Type of controller: PI controller, cycle 15 min.
- Adjustment bandwidth: 2° K of proportional band
- Adjustment speed: 7,5 Cycles / h (8 min cycle)
- Temperature sensor: NTC 100 K
- Dimensions: H86 × W125 × D32 mm
- Color: RAL 9010



NOVAMASTER RF MINI

Single-channel radio receiver for controlling NC / NO actuators in underfloor heating systems

Desired values transmitted by radio signal (868 MHz). Combinable with room thermostats NovaStat RF Basic, NovaStat RF Digital and NovaStat RF Week

TECHNICAL DATA

- Order no.: 206.1659.000
- Operating voltages: 230 VAC / NC / NO / 50 Hz ± 10 %
- Operating temperature: 0–50 °C (32–122 °F)
- Switching output: Receiver relay 12 A 250 VAC max.
- Quantity of actuators: Max. 2 actuators (parallel)
- Radio frequency: 868 MHz, < 10 mW
- Certification: CE.EN 300220-1, EN 301489-1
- Type of protection: Protection class II IP 30
- Dimensions: H170 × W28 × D14 mm
- Color: RAL 9010

NOVAMASTER RF | RADIO RECEIVER WIRING MODULE



1 NOVAMASTER RF LOGIC

Wiring module in combination with receiver unit Novamaster RF Logic for the wiring of electrothermal actuators and assignment of the individual wireless room thermostats

Expansion possible with Novamaster RF SlaveBox to provide further connection options. Direct wall mounting or mounting on DIN rail. Control of 230 V NC/NO actuators. Operating status indicated by LEDs. 2 separate, floating switching outputs on Novamaster RF Logic wiring module for actuating pumps. Programmable timer function for zone concerned. Integrated user programs, 9 fixed and 12 freely programmable for each individual zone. Digital display for program, time and function.

TECHNICAL DATA

- Order no.: 258.9317.000
- Operating voltage: 230 VAC 50 Hz ± 10 %
- Operating temperature: 0–50 °C (32–122 °F)
- Radio frequency (Timer): 868 MHz, < 10 mW
- Certification: CE.EN 300220-1, EN 301489-1
- Number of zones: 6 (max. 4 drives / zone)
- Max. quantity of actuators: 24 × 230 VAC
- Quantity of actuators / Zone: max. 4 drives / zone
- Type of controller: PI controller proportional bandwidth 2° K/1, 2° K
- Type of protection: Protection class II IP 30
- Switching outputs: 2 × separate, floating for pump switching max. 8 A
- Dimensions: H88 × W370 × D58 mm
- Color: RAL 9010

2 NOVAMASTER RF SLAVEBOX

Expansion module for the NovaMaster RF Logic module for the extended wiring of electrothermal actuators

Assignment of the room thermostats takes place via the Novamaster EL Timer. Pluggable expansion and direct wall mounting or mounting on DIN rail. Control of 230 V NC/NO actuators. Operating status indicated by LEDs.

TECHNICAL DATA

- Order no.: 258.9319.000
- Operating voltage: 230 VAC 50 Hz \pm 10 %
- Operating temperature: 0–50 °C (32–122 °F)
- Number of zones: 4 (max. 4 drives / zone)
- Max. number of actuators:
 Σ Novamaster RF Logic + Novamaster RF SlaveBox = 24 \times 230 VAC
- Type of protection: Protection class II IP 30
- Dimensions : H88 \times W160 \times D58 mm
- Color: RAL 9010



SYSTEM TECHNOLOGY

The demand for universal solutions in building services is greater than ever. Connection-ready heat interface units, fresh hot water, storage loading and solar energy stations from Taconova are highly evolved systems employing state-of-the-art technology.

Taconova quality products are assembled from carefully selected, tried-and-tested products to create perfectly functioning standard units.

The ready-to-use complete solutions simplify and accelerate planning and assembly stages. In everyday use they guarantee reliable operation, reduce maintenance to a minimum and optimize energy costs.

Taconova adheres consistently to the system concept: the fresh hot water solar and storage loading stations can be combined ideally. The energy storage system for supplying heat and domestic hot water is the centerpiece of the heating system. The solar energy transmitted via the solar and storage loading stations is stored here and can be transferred at floor level either by means of centralized fresh hot water technology or decentralized heat interface units (domestic hot water and heating energy).

CONFIGURATOR

How do you lay out your fresh hot water stations?

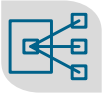

With the [Taconova Configurator](#) you can work out the rough design in six quick steps - including a request for quotation!

The screenshot shows the Taconova Configurator interface. On the left is a navigation menu with the following items: 'System temperatures', 'Property details*' (highlighted in blue), 'Evaluation*', 'Summary', and 'Request offer'. The main content area is titled 'Largest draw-off point per apartment' and 'Selection of facilities *'. It displays five options with corresponding images: 'bathtub', 'shower', 'rain shower', 'sink unit', and 'washbasin'.

INTELLIGENT STATIONS

Taconova's sophisticated stations are equipped with all the necessary valves and safety features and meet all the requirements of modern machine engineering.

OVERVIEW OF PRODUCT GROUPS



THE ALL-ROUNDER

The TacoTherm Dual Piko and Nano heat interface units: fresh hot water and heating in one station. The modular all-in-one stations supply hot water and regulate the hot water outlet temperature precisely and without auxiliary energy if so required. In addition, they regulate and distribute the heating water to the underfloor heating systems – for radiators and/or panel heating systems depending on requirements.



THE INSTANT STATION

Taconova connection-ready fresh hot water stations dispense with the need for storing domestic hot water. They therefore avoid hygiene problems and loss of energy as a result of storage and standby losses. The water is only heated on demand directly by means of a stainless steel plate heat exchanger and the hot water temperature is controlled electronically. The Mega3 and Peta2 series are also cascadable and are thus ideal for covering wide performance ranges. The fresh hot water stations can be ideally combined with the TacoSol Load storage loading stations.



THE POWERFUL STATION

The ready-to-connect TacoSol Load Mega station is a solar station and loading module in one. It was developed to load central buffer cylinders via a solar thermal system. Captured solar energy is transferred to the stratification cylinders via highly efficient stainless steel plate heat exchangers.



THE INDEPENDENT SOLUTION

All TacoSol Circ solar loading stations come with integrated hydronic balancing, flow measurement and flow control. The dual-phase versions increase their effectiveness through the automatic air separation in the integrated ventilating flask.



COMPACT

The TacoHeat Mix heating circuit pump assembly is delivered connection-ready, making it quick and easy to install. It features the latest generation of circulation pumps and ensures low power consumption. The integrated 3-way mixer always provides the correct flow rate and temperature at the consumer.

DRINKING WATER STORAGE IS YESTERDAY'S NEWS

Supplying domestic hot water then and now – forward-looking solutions dispense with hot water storage.

Heated drinking water in multistory residential buildings or in public buildings is often supplied by means of a domestic hot water storage tank. This domestic hot water has to be stored at temperatures of at least 60 °C in order to ensure drinking water hygiene.

This gives rise to the following disadvantages:

- High investment in the choice of materials suitable for drinking water, for example stainless steel
- Calciferous deposits as a result of permanent supply, warming and storage of drinking water
- High maintenance costs and poor access to integrated components, such as storage heat exchangers, spray lances, sacrificial anodes
- Risk of corrosion with coated storage units owing to permanent oxygen injection
- High hygiene risk from germ formation, especially in the drinking water storage tank in case of non-compliance with prescribed storage temperatures, for example failure or malfunction of the heat source

Storing energy in water as a medium remains the most efficient solution for handling the costs for space heating and hot water. It is meanwhile already recommended in standards such as DIN 1988-200, for example, that this energy be provided in a storage tank in the form of treated hot water.

This gives rise to the following advantages:

- No calciferous deposits in the tank as the process water is in the closed system
- No storage fittings and associated maintenance costs
- Lower investment costs as materials for heating and storing water do not have to be suitable for drinking water
- Simple hydraulic integration of any heat sources, such as heat pumps for example
- Low flow temperatures from low-temperature systems can be realized
- No hygiene risks even at operating temperatures < 60 °C in the storage unit

ADVANCED PREPARATION OF DOMESTIC HOT WATER

A fresh hot water station is the ideal link between the storage tank and hygienic domestic hot water.

With centralized and decentralized preparation of domestic hot water in accordance with the continuous flow principle, drinking water is only heated as needed and only in the quantity required at the time. Country-specific standards, such as DIN or SIA, also allow a reduction in the domestic hot water temperature in this context to < 60 °C, especially for decentralized preparation of domestic hot water. Many European standards furthermore require that the volume of domestic hot water stored be reduced and only the required quantity heated. Examples of such standards include: ÖNORM B 5019:2011 (5.7.3 and 5.8.3), SIA 385/1 2020 and DIN 1988-200 (9.7.2.7).

THIS OFFERS SYSTEM PLANNERS AND OPERATORS THE FOLLOWING ADVANTAGES:

- Energy savings through reduced volumes of domestic hot water in case of thermal disinfection
- Fewer calciferous deposits in the heat exchanger owing to the low temperature level and turbulent flows
- Reduced circulation losses owing to the low temperature level
- Lower maintenance costs thanks to simple access to external plate heat exchangers
- Reduced hygiene risk for domestic hot water as heated drinking water is not allowed to stagnate

CENTRALIZED OR DECENTRALIZED?

When it comes to planning fresh hot water stations, the choice is yours.

ENERGY TRANSFER AT FLOOR LEVEL

The energy storage system for supplying heat and domestic hot water is the centerpiece of the heating system. The thermal energy stored here can be transferred at floor level either by means of centralized fresh hot water technology or decentralized heat interface units (domestic hot water and heating energy).

CENTRALIZED PREPARATION OF DOMESTIC HOT WATER

The **station** is planned to be in the **immediate vicinity of the storage tank** in the case of centralized preparation of domestic hot water.

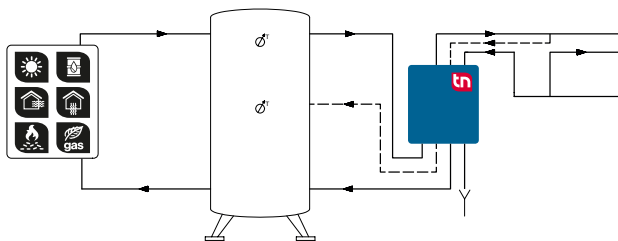

One of these systems can supply heated drinking water for up to 200 apartments taking account of the simultaneous dispensing of the domestic hot water. The stations can be connected individually to the domestic hot water network in this scenario or also cascaded.

DECENTRALIZED PREPARATION OF DOMESTIC HOT WATER

Decentralized fresh hot water stations or heat interface units operate according to the same technical principle as centralized systems.

The energy required to prepare domestic hot water is provided by means of the central storage tank and transported to the apartment via a riser pipe pump. The **fresh hot water stations are installed directly in the apartments** with this type of installation.

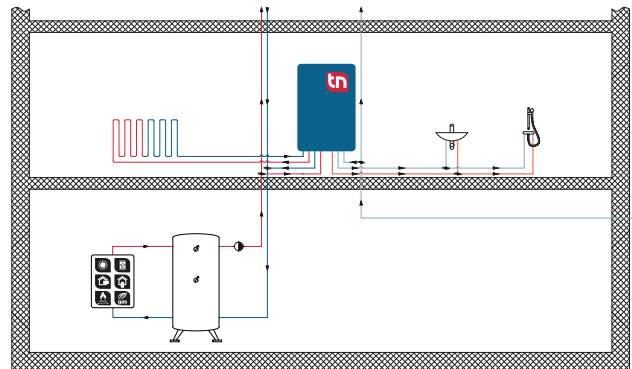

Decentralized heating of drinking water – where only ejector lines are used – allows the risk level of Legionella to be reduced to "low". As the volume of domestic hot water is consequently reduced to <math>< 3\text{ l}</math>, these heat interface units are classed as small installations in the sense of the German Drinking Water Regulations from November 2015 and are therefore not subject to any special mandatory testing. In combination with connecting piping for radiators or underfloor heating, the heat interface unit becomes the central point of access for supplying energy in an apartment.

This allows energy consumption to be recorded and calculated on an individual apartment basis. The heat meter takes on the role of an apartment energy meter and there is no need for domestic hot water meters.

BROCHURE CENTRAL DOMESTIC HOT WATER TECHNOLOGY (HIU)



BROCHURE DECENTRALISED DOMESTIC HOT WATER TECHNOLOGY



MODULAR HEAT INTERFACE UNITS

The modular TacoTherm Dual Piko or Nano heat interface units distribute heat energy and handle decentralized preparation of hot water in apartments in accordance with the continuous flow principle.

BENEFITS AT THE PLANNING STAGE

- The compact design and, if required, small installation depth make space planning easier
- Efficient planning thanks to modular basic concept with large number of variants
- On-demand, hygienic preparation of domestic hot water
- Demand-driven calculation of energy costs
- Fixed value-controlled or weather-controlled versions available

BENEFITS AT THE INSTALLATION STAGE

- High levels of prefabrication ensure fast and simple installation and startup and therefore time savings
- Service and warranty from a single source
- Reliable operation thanks to high-quality components
- Easier to provide proof of drinking water quality
- Simple, retrospective fitting of heat meters possible

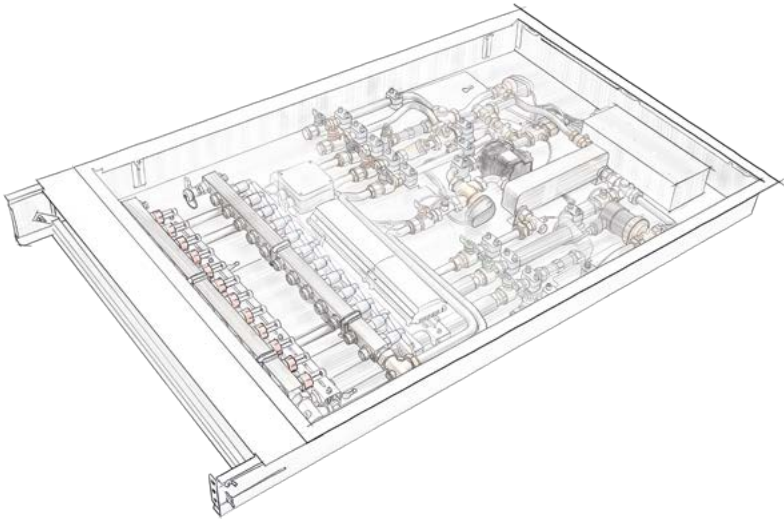

SYSTEM / BASIC DIAGRAM

The TacoTherm Dual heat interface units adapt ideally to local conditions.

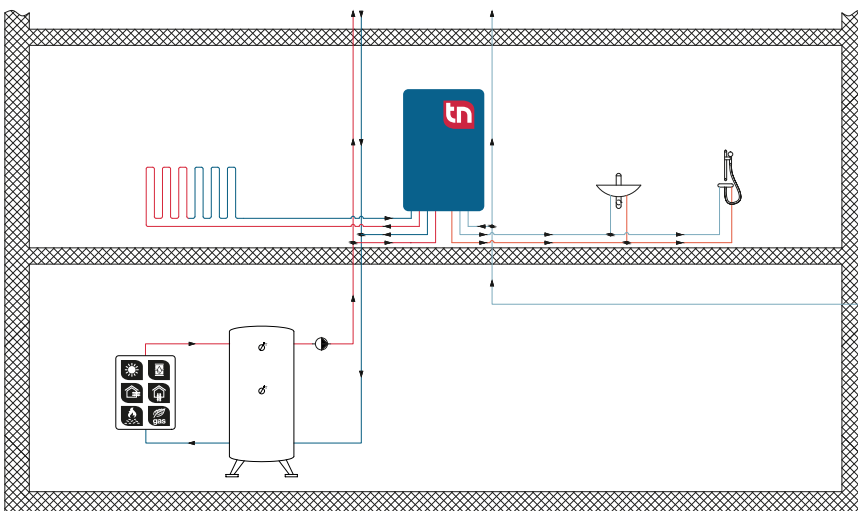





HEAT INTERFACE UNIT – PROVEN SYSTEM

High levels of prefabrication and low maintenance systems deliver valuable savings in terms of assembly time and make servicing almost redundant. Yet the heat interface units also offer many further advantages.



TacoTherm Dual Piko heat interface unit

The modular design of the TacoTherm Dual Piko offers optimum functionality and gives you free rein when arranging the modules. The modules impress with their flat construction (110 mm). You can position the station how and where you wish: vertically, horizontally and even in separate rooms.

Product photo	Station / Typ	Dispensing rate / heating circuits	Dimensions in mm (W×H×D)	Version
	TacoTherm Dual Piko PM Combination Station	22 l/min* up to 10 heating circuits	874 × 1420–1510 × 110	<ul style="list-style-type: none"> Compact, combined and connection-ready heat interface unit Fresh hot water station with heating module, preparation of fresh hot water, underfloor heating manifold and separate radiator connection in one
	TacoTherm Dual Piko Smart Connect Combination Station	25 l/min** up to 12 heating circuits	874 × 1501–1591 × 110	
	TacoTherm Dual Piko Piko PM Fresh Hot Water Module	22 l/min*	874 × 772–892 × 110	<ul style="list-style-type: none"> Compact, connection-ready fresh hot water station Proportional flow-controlled or electronically controlled with options such as standby module and anti-scald protection for increased comfort
	TacoTherm Fresh Smart Connect Fresh Hot Water Module	25 l/min**	874 × 1501–1591 × 110	
	TacoSys Piko Heating Module	up to 10 heating circuits	874 × 772–892 × 110	<ul style="list-style-type: none"> Compact, connection-ready heating module Fixed value or weather-controlled

TacoTherm Dual Nano heat interface unit

The fresh water module and combination station in the Nano series impress with their slender construction (minimum 450 mm). They offer optimum functionality and give you free rein when planning the assembly of the modules. The fresh water module in this series can be used ideally as a gas boiler replacement unit.

Product photo	Station / Typ	Dispensing rate / heating circuits	Dimensions in mm (W×H×D)	Version
	TacoTherm Dual Nano Combination Station	20 l/min* up to 10 heating circuits	523 × 1233– 1323 × 153 (8 circuits) 750 × 1233– 1323 × 153 (9–10 circuits)	<ul style="list-style-type: none"> Compact, combined and connection-ready heat interface unit Fresh hot water station with heating module, preparation of fresh hot water, underfloor heating manifold and separate radiator connection in one
	TacoTherm Fresh Nano Fresh Hot Water Module	20 l/min*	450 × 635 × 156	<ul style="list-style-type: none"> Connection-ready fresh hot water station Suitable for replacement of gas boilers Proportional flow-controlled with options such as standby module and anti-scald protection for increased comfort

* Performance data for primary = flow 70 °C / secondary = hot water 45 °C; Δp ≥ 300 mbar

** Performance data for primary = flow 55 °C / secondary = hot water 45 °C; Δp ≥ 300 mbar

TACOTHERM DUAL PIKO

HEAT INTERFACE UNIT



Preconfigured heat interface unit with compact installation depth for preparation of potable hot water and apartment heating.

DESCRIPTION

The heat interface unit in the Piko series suits practically any installation situation thanks to its compact installation depth and versatile constructions. The stations are available as individual fresh hot water modules or heating modules as well as combination stations. Various selectable hydraulic components ensure on-demand preparation of potable hot water, distribution of heat energy as well as calculation of energy costs.

INSTALLATION

The heat interface units can be installed as a compact station or in a split design. For ease of transport, the compact version can be dismantled conveniently into two parts and reassembled using the available plug connection. Ideally the station should be placed next to the outlets for the apartments. The individual modules can be assembled horizontally as well as installed at separate locations in the split design.

ADVANTAGES

- Compact installation depth
- Large number of variants
- Preconfigured for simple installation
- On-demand, hygienic, decentralised DHW heating
- Reduction of stored DHW volume to a minimum
- Demand-driven calculation of energy costs

OPERATION

The heat interface units in the Piko series are designed for preparation of potable hot water and distribution of heat energy in multistory residential buildings. Primary energy is supplied via a central buffer cylinder; decentralised DHW heating takes place in the domestic hot water module as required, according to the instantaneous water heating principle. In the case of combination stations, the heating surfaces in living areas are connected with the Underfloor heating circuit manifolds of the heating module or the radiator connections. The heating flow temperature in the living area is regulated on a fixed-value or weather-controlled basis. Adjusting pieces are provided in the modules for on-site installation of heat meters and cold water meters.

BUILDING CATEGORIES

- Apartment blocks
- Hotels and residential homes
- Industrial buildings

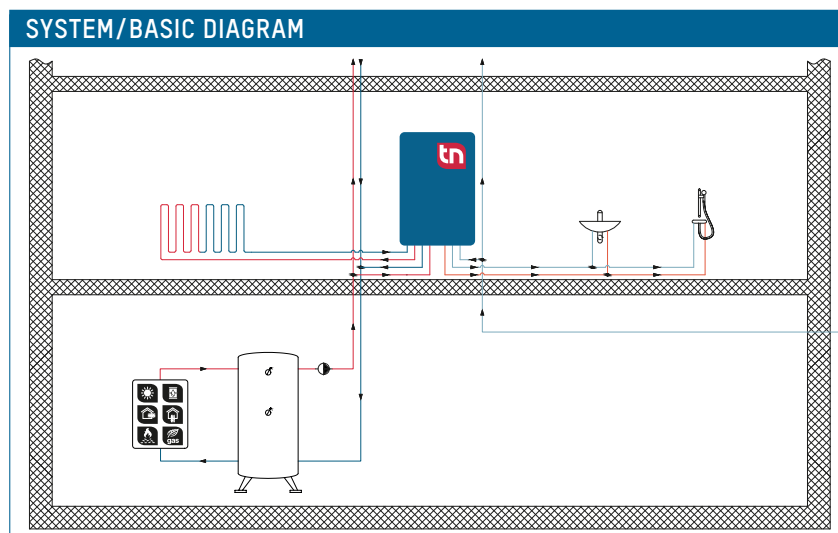

KEY

Available for this type
Selectable components (either / or)
Not available for this type

				TacoTherm Dual Piko							
				Version of fresh hot water module				SMART Connect			
				Pages in datasheet				8 - 13			
				Variant							
				A	B	C	D	A	B	C	D
FRESH HOT WATER MODULE	Heat exchanger	Suitable for	Standard heat source								
			Operation with heat pumps								
		Materials	Copper-soldered								
			Nickel-soldered								
	Stainless steel-soldered										
	Control type	Type	Proportional flow								
			Electronic regulator								
		Balancing	Static (TacoSetter Inline)								
			Dynamic								
		Secondary	Mixer								
	Comfort	Circulation									
	Connections	Heating / Radiator	Keep warm function								
			Bottom								
			Top								
			Left								
	Installation options		Right								
Base plate											
Flush-mounted frame with door											
Flush-mounted frame without door											
Surface-mounted cabinet with door											
Surface-mounted cabinet without door											
Door accessories (optional)		Spagnolet lock									
	Locking cylinder										
HEATING MODULE	Regulation	Type	Fixed value								
			Weather-controlled								
		Balancing	Dynamic								
			Static								
	Underfloor heating circuit manifold	Number of heating circuits	2 - 10								
			2 - 12								
	Distributor accessories		Distributor valve with TacoDrive actuator								
			Connector module for Actuators NovaMaster								
Primary pipe system	See next page for explanation	2-pipe									
		3-pipe									
		4-pipe									

NOTE

REQUIREMENTS FOR FLOW MEDIA

A copper-brazed stainless steel plate heat exchanger is used as standard for the proportional flow-controlled stations. It must be checked prior to use in the framework of system planning whether the issues of corrosion protection and scale formation have been sufficiently taken into account in accordance with DIN 1988200 and current potable water analyses according to DIN EN 8065. See datasheet „Plate Heat Exchanger Requirements - Limit Values for Drinking Water Quality“.

SPECIFICATION TEXT

See www.taconova.com

GENERAL TECHNICAL DATA

General

- Max. operating pressure $P_{0\ max}$:
 - Primary: 3 bar
 - Secondary: 6 bar
- Overall dimensions of combination station: W 874 mm × H 1420 - 1510 mm × D 110 mm
- Weight of combination station (empty): 70 kg

Materials

- Galvanized or varnished sheet steel housing according to model
- Pipes: DN 20 stainless steel 1.4404
- Pumps: cast iron
- Valve housing: brass
- Seals: AFM34 (flat sealing)

Performance data

See design diagram

Electrical connection data

- Mains voltage: 230 VAC ± 10 %
- Mains frequency: 50...60 Hz
- Power consumption: max. 4 - 60 W
- Protection type: IP 30
- EEL ≤ 0,20 – Part 2

Flow media

- Heating water (VDI 2035; SWKI BT 102-01; ÖNORM H 5195-1)
- Cold water as per DIN 1988-200 and DIN EN 806-5

APPROVALS / CERTIFICATES

- Components in contact with potable water comply with UBA Evaluation Criteria 26/03/2018 and Directive (EU) 2015/1535

TECHNICAL DATA

FRESH HOT WATER MODULE

General

- Max. operating temperature $T_{0\ max}$: 95 °C
- Weight (empty): 35 kg
- Dimensions: W 874 mm × H 772 - 892 mm × D 110 mm

Material

- Plate heat exchanger (plates and connector pieces):
 - Stainless steel 1.4401
 - Copper-soldered / nickel-soldered

TECHNICAL DATA HEATING MODULE

General

- Max. operating temperature $T_{0\ max}$: 70 °C
- Weight (empty): 30 kg
- Dimensions: W 874 mm × H 772 - 892 mm × D 110 mm
- High-efficiency circulating pump: TacoFlow2 ADAPT Underfloor heating circuit manifold
- 3-way mixing valve (fixed value-controlled) or PICV valve with actuator (weather-controlled)

TYPE OVERVIEW

TacoTherm Dual Piko | Combination station with 10 heating circuits *1)

Order no.	DN	Rp	Dispensing range *2)	Heat exchanger
276.2111.139	20	1" OT	up to 22 l/min (58.5 kW)	copper-soldered

TacoTherm Fresh Piko | Fresh hot water station

Order no.	DN	Rp	Dispensing range *2)	Heat exchanger
276.2102.000	20	1" OT	up to 22 l/min (58.5 kW)	copper-soldered

* 1) Any matching accessories required and variants can be individually selected

* 2) Performance data for primary = flow 70 °C / secondary = hot water 45 °C; $\Delta p \geq 300$ mbar

DIMENSIONAL DRAWING

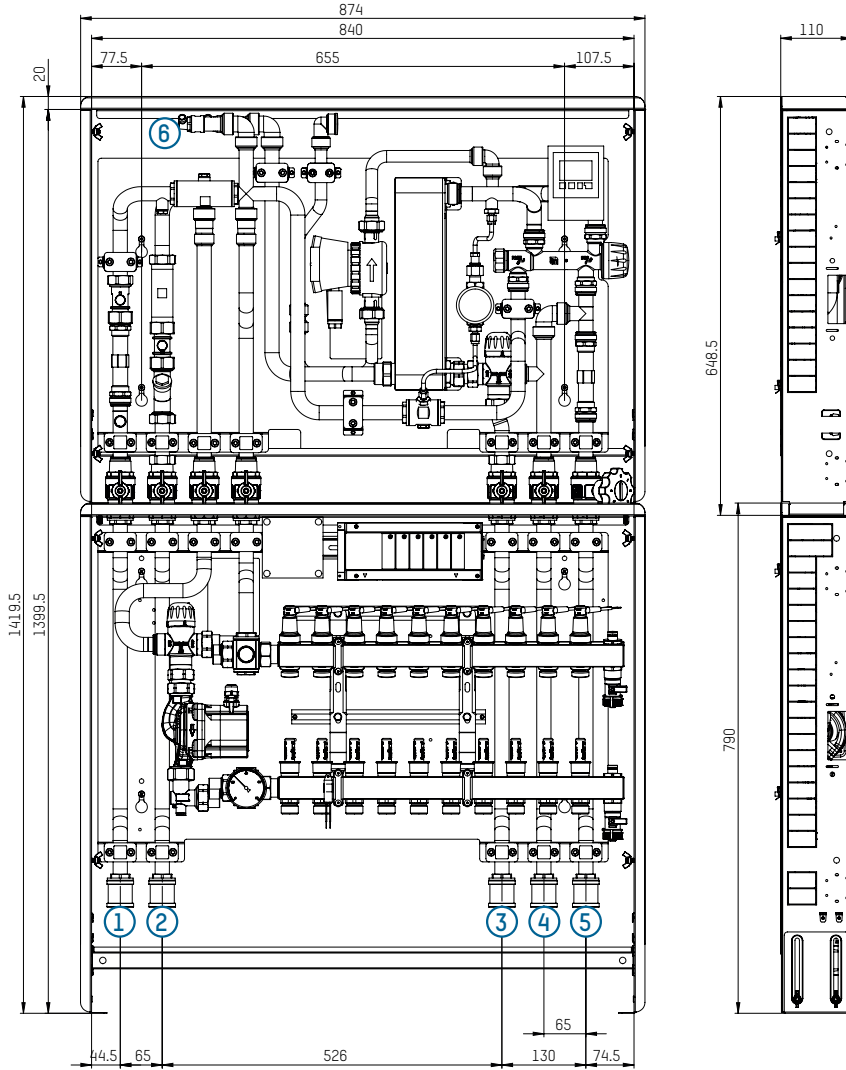

- 1 Primary connection for heat supply on return side
- 2 Primary connection for heat supply on supply side
- 3 Connection for hot water distribution
- 4 Connection for cold water distribution
- 5 Connection for main supply line for cold water
- 6 Radiator connection in supply and return circuit

FLOW DIAGRAM

Heating control: Fixed value
 Static hydronic balancing
 Connection for 2-pipe system

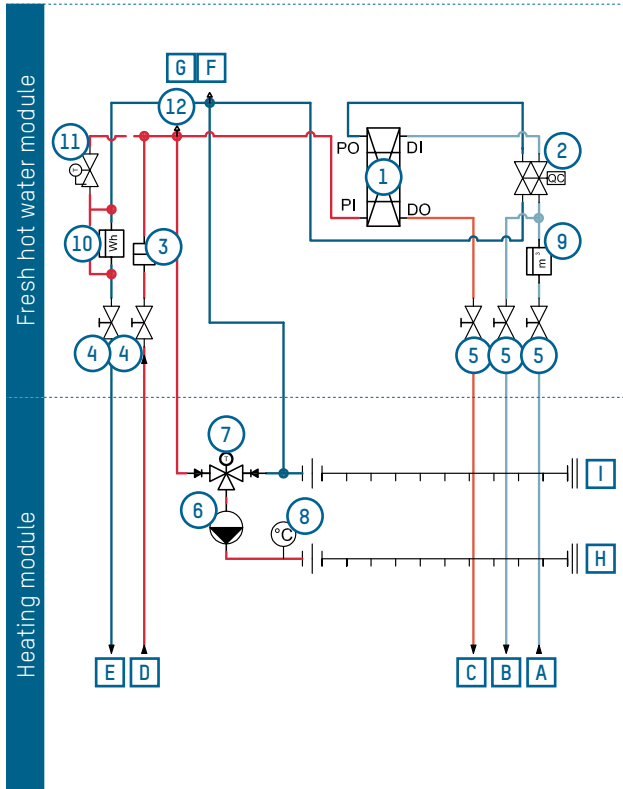

Heating control: Weather-controlled
 Dynamic hydronic balancing
 Connection for 2-pipe system

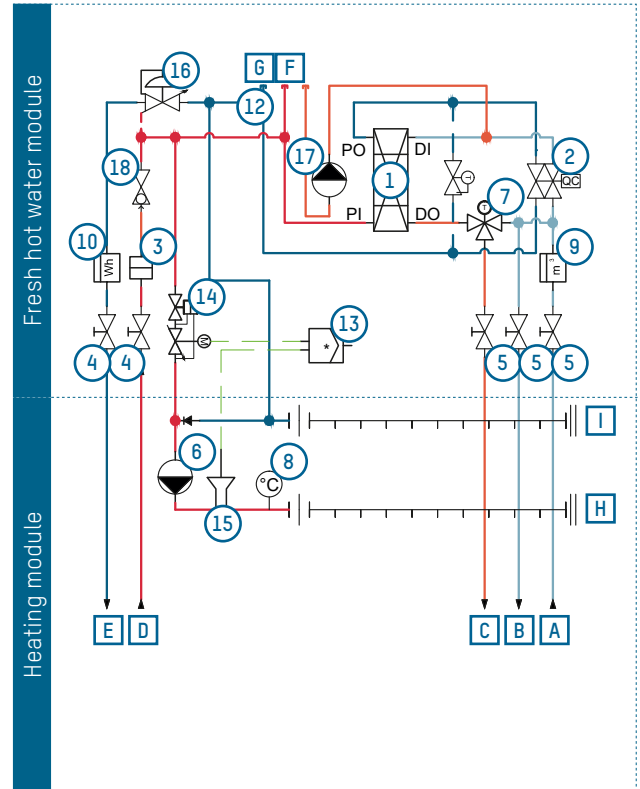

Key

- 1 Plate heat exchanger
- 2 Proportional flow controller
- 3 Dirt trap with filter
- 4 Shut-off valve for heating
- 5 Shut-off valve with domestic hot water certification
- 6 Heating circuit pump
- 7 Fixed-value three-way mixer (NovaMix Value)
- 8 Thermometer 0 - 60 °C
- 9 Cold water meter adjusting piece
- 10 Heat meter adjusting piece
- 11 Connection of optional temperature storage module
- 12 Automatic air vent valve
- 13 Weather-controlled regulation
- 14 Dynamic balancing valve with drive motor
- 15 Flow sensor weather-controlled regulation
- 16 Optional differential pressure controller
- 17 Optional circulation
- 18 Optional static balancing valve

Connections

- A Connection for main supply line for cold water
- B Connection for cold water distribution
- C Connection for hot water distribution
- D Primary connection for heat supply on supply side
- E Primary connection for heat supply on return side
- F Radiator connection in supply circuit
- G Radiator connection in return circuit
- H Connection for underfloor heating on supply side
- I Connection for underfloor heating on return side

FLOW DIAGRAM

Heating control: Weather-controlled
 Dynamic hydronic balancing
 Connection for 3-pipe system

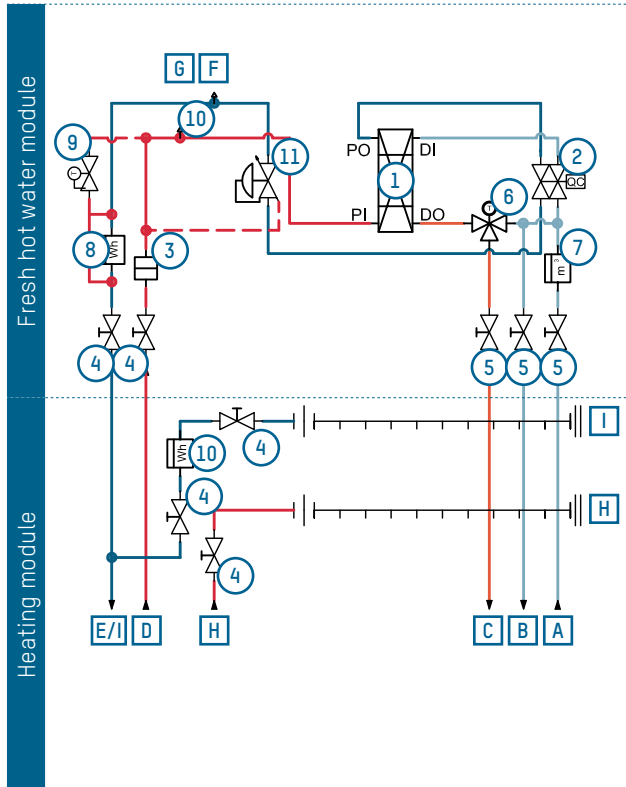

Key

- 1 Plate heat exchanger
- 2 Proportional flow controller
- 3 Dirt trap with filter
- 4 Shut-off valve for heating
- 5 Shut-off valve with domestic hot water certification
- 6 Fixed-value three-way mixer (NovaMix Value)
- 7 Cold water meter adjusting piece
- 8 Heat meter adjusting piece
- 9 Connection of optional temperature storage module
- 10 Automatic air vent valve
- 11 Optional differential pressure controller

Heating control: Fixed value
 Static hydronic balancing
 Connection for 4-pipe system

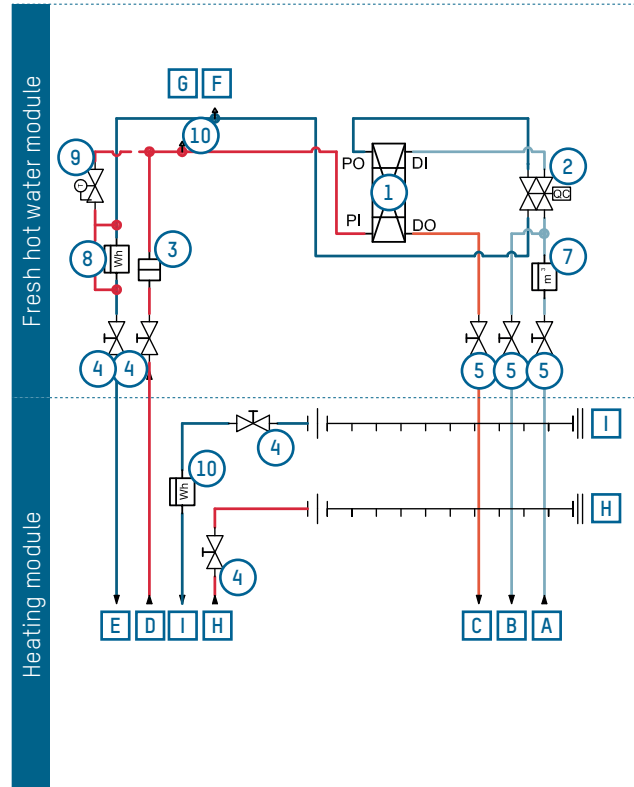

Connections

- A Connection for main supply line for cold water
- B Connection for cold water distribution
- C Connection for hot water distribution
- D Primary connection for heat supply on supply side
- E Primary connection for heat supply on return side
- F Radiator connection in supply circuit
- G Radiator connection in return circuit
- H Connection for underfloor heating on supply side
- I Connection for underfloor heating on return side

FLOW, TEMPERATURE AND PRESSURE LOSS DIAGRAMS

A) Secondary pressure loss

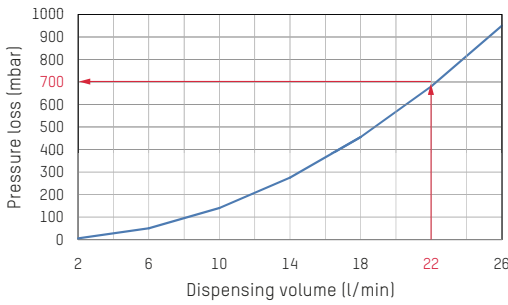

E) Hot water demand for 200 / 300 / 400 mbar

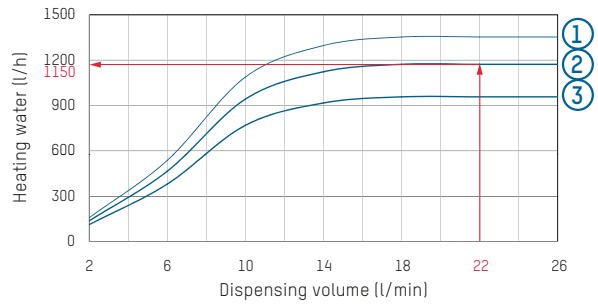

B) Domestic hot water temperature = 70°C

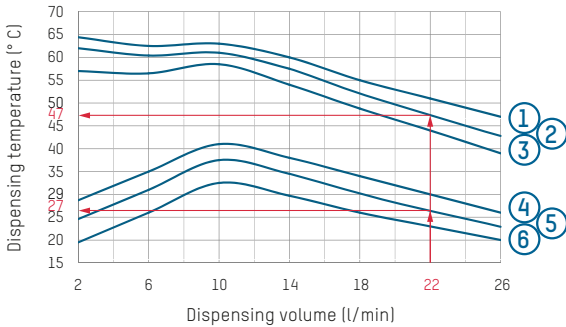

F) Domestic hot water temperature = 65°C

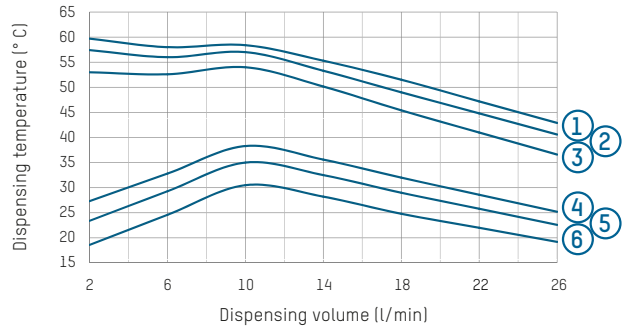

C) Domestic hot water temperature = 60°C

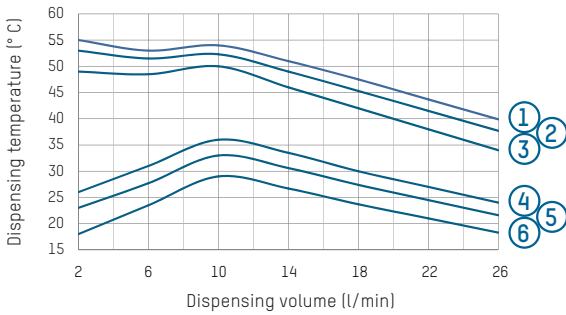

G) Domestic hot water temperature = 55°C

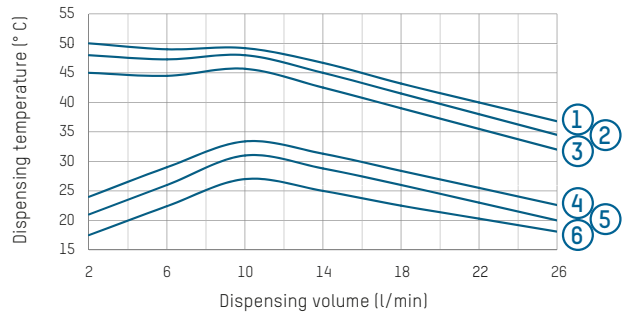

D) Domestic hot water temperature = 50°C

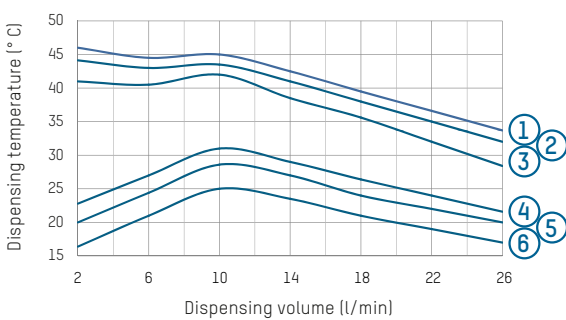

- 1 Dispensing temperature* for 400 mbar
- 2 Dispensing temperature* for 300 mbar
- 3 Dispensing temperature* for 200 mbar
- 4 Return temperature for Δp 400 mbar
- 5 Return temperature for Δp 300 mbar
- 6 Return temperature for Δp 200 mbar

* Temperature value without additional NovaMix mixing valve

EXAMPLE OF INTERPRETING THE FLOW RATE AND PRESSURE LOSS DIAGRAMS

Given

- Hot water dispensing volume: 22 l/min
- Primary heating flow temperature: 70°C
- Available primary differential pressure at the station of 300 mbar

Sought

- Domestic hot water demand in l/h
- Pressure loss on secondary side
- Dispensing temperature

- Primary heating return temperature in °C

- Secondary pressure loss in mbar

Approach

- In Diagram B) a hot water dispensing temperature of 47 °C can be read for the given hot water dispensing volume of 22 l/min at the intersection point with the differential pressure of 300 mbar, and the associated return temperature

can be read at the intersection point with the return temperature line at 300 mbar.

- Diagram A) shows the pressure loss in the system on the secondary side and Diagram E) shows a DHW demand of 1150 l/h at the intersection point between the dispensing volume and the 300 mbar differential pressure.

SPECIFICATION TEXT

See www.taconova.com

GENERAL TECHNICAL DATA

General

- Max. operating pressure $P_{0\max}$:
 - Primary: 6 bar
 - Secondary: 10 bar
- Overall dimensions of combination station: W 874 mm × H 1501 – 1591 mm × D 110 mm
- Weight of combination station (empty): 70 kg

Materials

- Galvanized or varnished sheet steel housing according to model
- Pipes: DN 20 stainless steel 1.4404
- Primary pump fresh hot water module: cast iron
- DHW circulation pump: brass
- Valve housing: brass
- Seals: AFM34 (flat sealing)

Performance data

See design diagram

Electrical connection data

- Mains voltage: 230 VAC ± 10 %
- Mains frequency: 50...60 Hz
- Power consumption fresh hot water module: max. 50 W
- Power consumption combination station incl. actuators: 120 – 140 W
- Protection type: IP 30
- EEI ≤ 0.20 – Part 2

Flow media

- Heating water (VDI 2035; SWKI BT 102-01; ÖNORM H 5195-1)
- Cold water as per DIN 1988-200 and DIN EN 806-5

APPROVALS / CERTIFICATES

- Components in contact with potable water comply with UBA Evaluation Criteria 26/03/2018 and Directive (EU) 2015/1535

TECHNICAL DATA

FRESH HOT WATER MODULE

General

- Max. operating temperature $T_{0\max}$: 90 °C
- Weight (empty): 35 kg
- Dimensions: W 874 mm × H 965 – 1055 mm × D 110 mm
- Primary pump: TacoFlow 3 GenS 15-85/130
- DHW circulation pump: TacoFlow 2 Pure

Materials

- Plate heat exchanger (plates and connector pieces):
 - Stainless steel 1.4401
 - Stainless-steel-soldered

TYPE OVERVIEW

TacoTherm Dual Piko Connect | Combination station with 12 heating circuits ^{*1)}

Order no.	DN	Rp	Dispensing range ^{*2)}	Heat exchanger
278.2311.140	20	∅ 18x1	up to 25 l/min	Stainless-steel-soldered

TacoTherm Fresh Piko Connect | Fresh hot water station

Order no.	DN	Rp	Dispensing range ^{*2)}	Heat exchanger
278.2301.000	20	¾" IT	up to 25 l/min	Stainless-steel-soldered

* 1) Any matching accessories required and variants can be individually selected

* 2) Performance data for primary = flow 55 °C / secondary = hot water 45 °C

DIMENSIONAL DRAWING

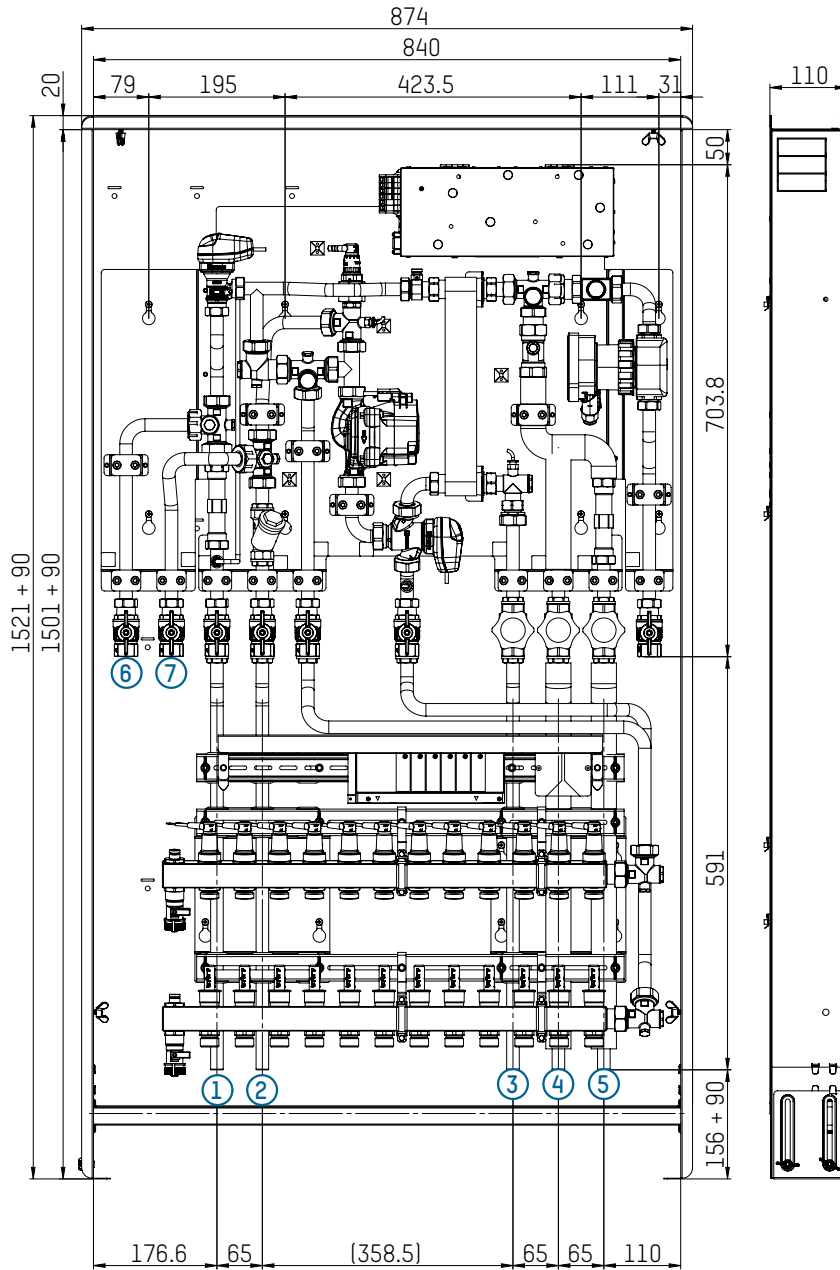

- 1 Primary connection for heat supply on return side
- 2 Primary connection for heat supply on supply side
- 3 Connection for hot water distribution
- 4 Connection for cold water distribution
- 5 Connection for main supply line for cold water
- 6 Radiator connection in return circuit
- 7 Radiator connection in supply circuit

FLOW DIAGRAM

Heating control: Fixed value and weather-controlled
 Connection for 2-pipe system

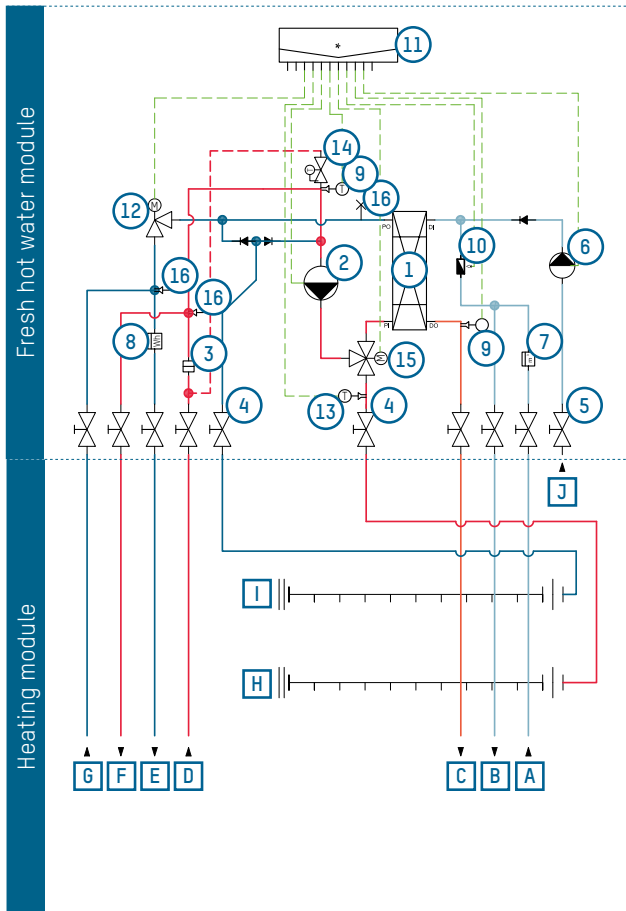

Key

- 1 Plate heat exchanger
- 2 Primary pump for domestic hot water and heating module
- 3 Dirt trap with filter
- 4 Shut-off valve for heating
- 5 Shut-off valve with domestic hot water certification
- 6 Optional DHW circulation pump
- 7 Cold water meter adjusting piece
- 8 Heat meter adjusting piece
- 9 Pressure/temperature sensor
- 10 Vortex Flow Sensor
- 11 Heat interface unit controller
- 12 Drive with stepper motor
- 13 Flow sensor weather-controlled regulation
- 14 Warming module actuator
- 15 Heating/DHW heating diverter valve
- 16 Automatic air vent valve

Connections

- A Connection for main supply line for cold water
- B Connection for cold water distribution
- C Connection for hot water distribution
- D Primary connection for heat supply on supply side
- E Primary connection for heat supply on return side
- F Radiator connection in supply circuit
- G Radiator connection in return circuit
- H Connection for underfloor heating on supply side
- I Connection for underfloor heating on return side
- J Connection for DHW circulation

FLOW DIAGRAM

Heating control: Fixed value
 Connection for 4-pipe system

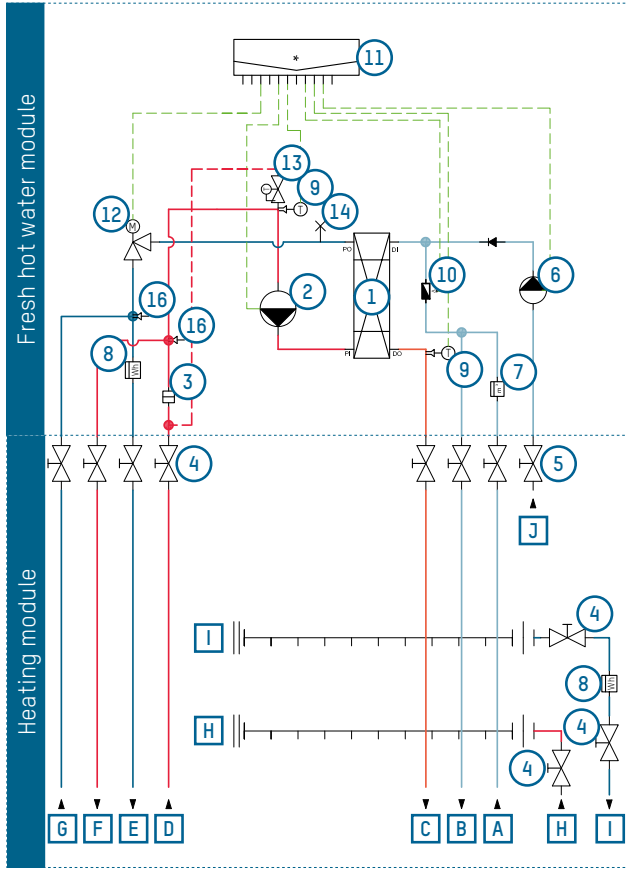

Key

- 1 Plate heat exchanger
- 2 Primary pump for fresh hot water
- 3 Dirt trap with filter
- 4 Shut-off valve for heating
- 5 Shut-off valve with domestic hot water certification
- 6 Optional DHW circulation pump
- 7 Cold water meter adjusting piece
- 8 Heat meter adjusting piece
- 9 Pressure/temperature sensor
- 10 Vortex Flow Sensor
- 11 Heat interface unit controller
- 12 Drive with stepper motor

Connections

- A Connection for main supply line for cold water
- B Connection for cold water distribution
- C Connection for hot water distribution
- D Primary connection for heat supply on supply side
- E Primary connection for heat supply on return side
- F Radiator connection in supply circuit
- G Radiator connection in return circuit
- H Connection for underfloor heating on supply side
- I Connection for underfloor heating on return side
- J

FLOW AND PRESSURE LOSS DIAGRAMS COLD WATER HEATING BY 35 K (10 ... 45 °C)

D) Secondary pressure loss

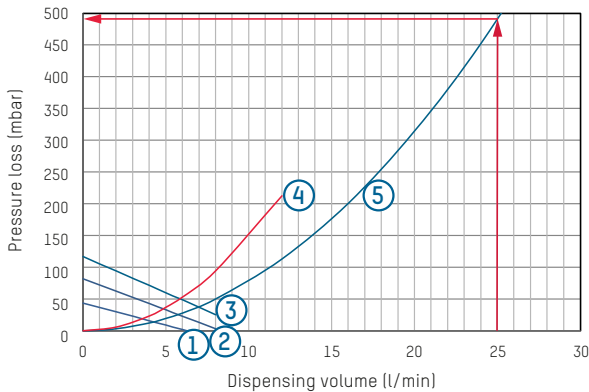

Key

- 1 DHW circulation pump stage 1
- 2 DHW circulation pump stage 2
- 3 DHW circulation pump stage 3
- 4 Circulation pressure drop
- 5 Secondary pressure drop
- 6 Heating water flow rate limit at 300 mbar

A) Heating water demand, primary

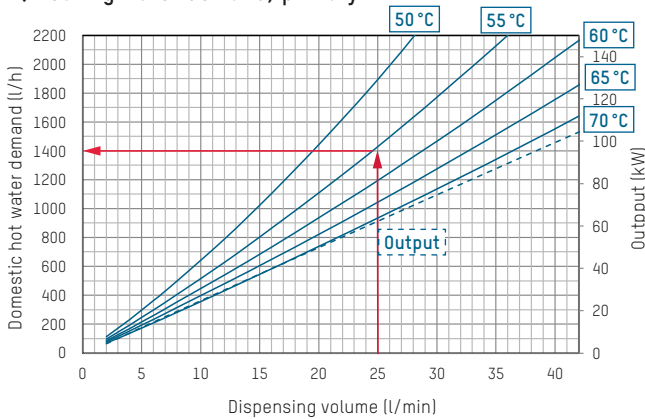

B) System output depends on primary pilot pressure

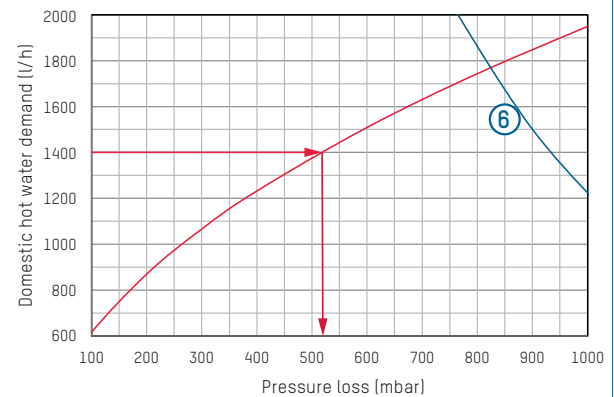

C) Return temperatures on primary side

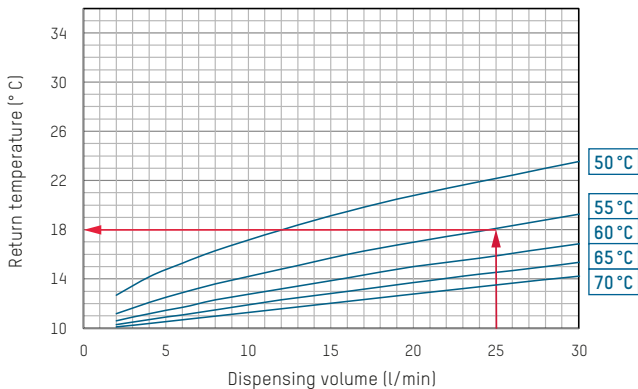

EXAMPLE OF INTERPRETING THE FLOW RATE AND PRESSURE LOSS DIAGRAMS

Given

- Hot water dispensing volume: 25 l/min
- Primary heating flow temperature: 55 °C
- Draw-off temperature: 45 °C
- Pilot pressure at station, primary: 300 mbar

Sought

- Domestic hot water demand in l/h
- Primary pressure loss in mbar
- Primary heating return temperature in °C
- Secondary pressure loss in mbar
- System output monitoring

Approach

- From graph A), the heating water flow rate of 1420 l/min can be read off at the intersection of the given DHW draw-off rate and the existing primary flow temperature.
- On graph B), the primary side pressure loss (520 mbar) can be read off from the determined hot water flow rate of 1400 l/h. The point of intersection must lie below the highest possible heating water flow rate (300 mbar).

- In Diagram C) the primary return temperature for the given dispensing volume and the selected flow temperature of 55 °C is then 18 °C.
- In Diagram D) the secondary pressure loss for the given data is 480 mbar

**FLOW AND PRESSURE LOSS DIAGRAMS
COLD WATER HEATING BY 45 K (10 ... 55 °C)**

E) Secondary pressure loss

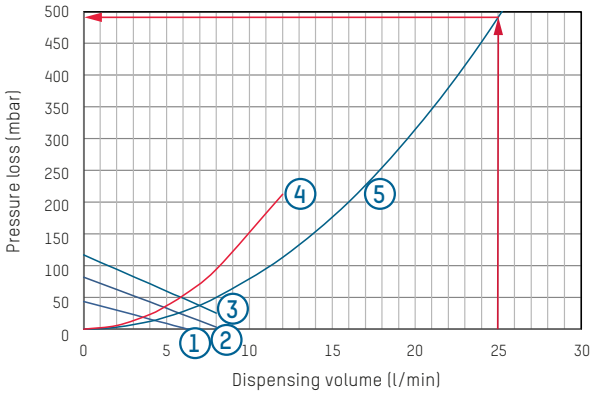

Key

- 1 DHW circulation pump stage 1
- 2 DHW circulation pump stage 2
- 3 DHW circulation pump stage 3
- 4 Circulation pressure drop
- 5 Secondary pressure drop
- 6 Heating water flow rate limit at 300 mbar

A) Heating water demand, primary

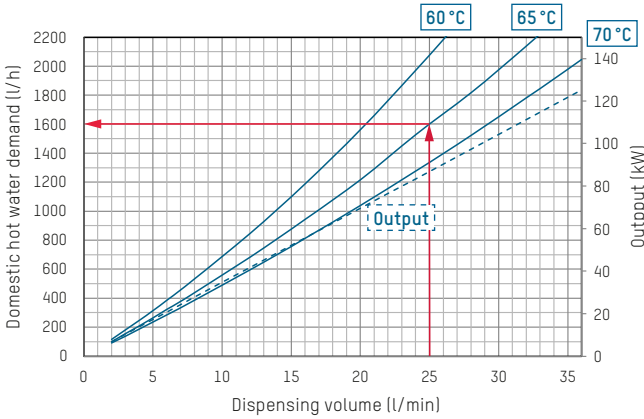

B) Residual head | Primary pressure loss

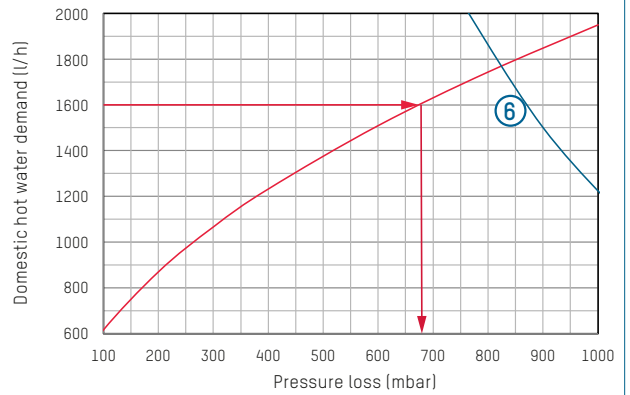

C) Return temperatures on primary side

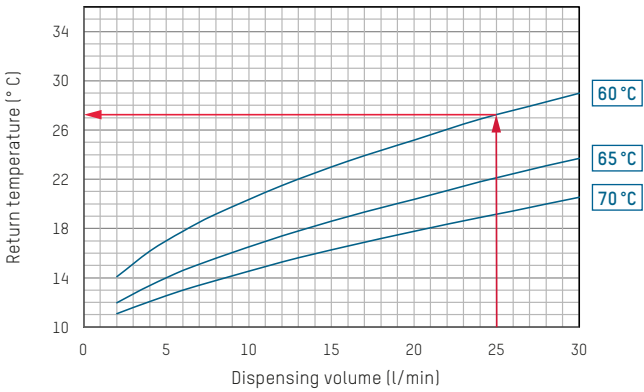

SPECIFICATION TEXT

See www.taconova.com

TECHNICAL DATA

General

- Max. operating pressure $P_{0\ max}$: 3 bar
- Max. operating temperature $T_{0\ max}$: 70 °C
- Dimensions: W 874 mm × H 772 – 892 mm × D 110 mm
- Weight (empty): 30 kg

Materials

- Galvanized or varnished sheet steel housing according to model
- Pipes: DN 20 stainless steel 1.4404
- Pumps: cast iron
- Valve housing: brass
- Seals: AFM34 (flat sealing)

Performance data

See design diagram

Electrical connection data

- Mains voltage: 230 VAC ± 10 %
- Mains frequency: 50...60 Hz
- Power consumption: max. 4 – 60 W
- Protection type: IP 30
- $EEL \leq 0,20$ – Part 2

Flow media

- Heating water (VDI 2035; SWKI BT 102-01; ÖNORM H 5195-1)
- Cold water as per DIN 1988-200 and DIN EN 806-5

Fittings dependent on model

- High-efficiency circulating pump: TacoFlow2 ADAPT
- 3-way mixing valve with fixed-value control
- Underfloor heating circuit manifold TacoSys 2-12 heating circuits
- Electro-thermal actuators
- NovaMaster connector module
- Electronic controller with display
- PICV valve

TYPE OVERVIEW

TacoSys Piko | Heating module with 10 heating circuits

Order no.	DN	Rp	Heating circuit connections	Measuring range Supply TopMeter
276.0012.139	20	1" OT	¾" OT	0 – 5 l/min

DIMENSIONAL DRAWING

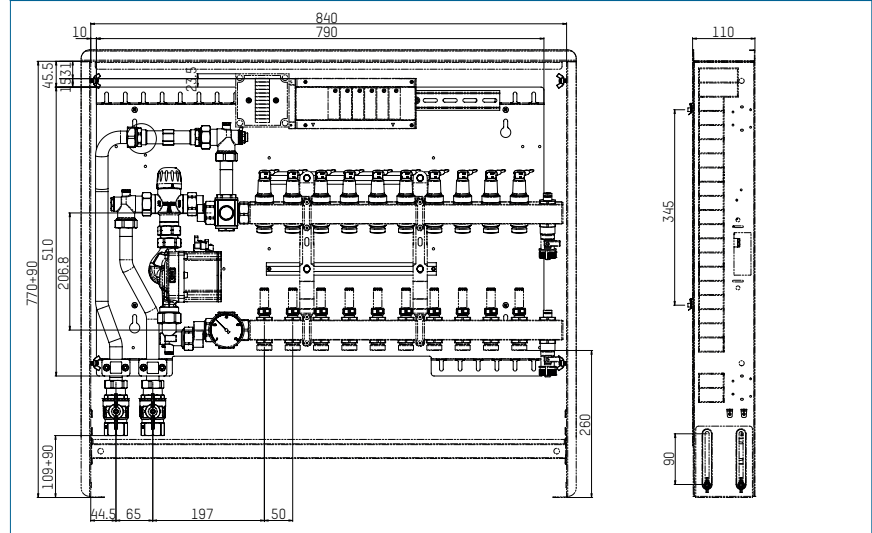

FLOW AND PRESSURE LOSS DIAGRAMS

For heating module with mixing station and fixed-value control and with open TopMeters and valves. Pump: TacoFlow2 ADAPT

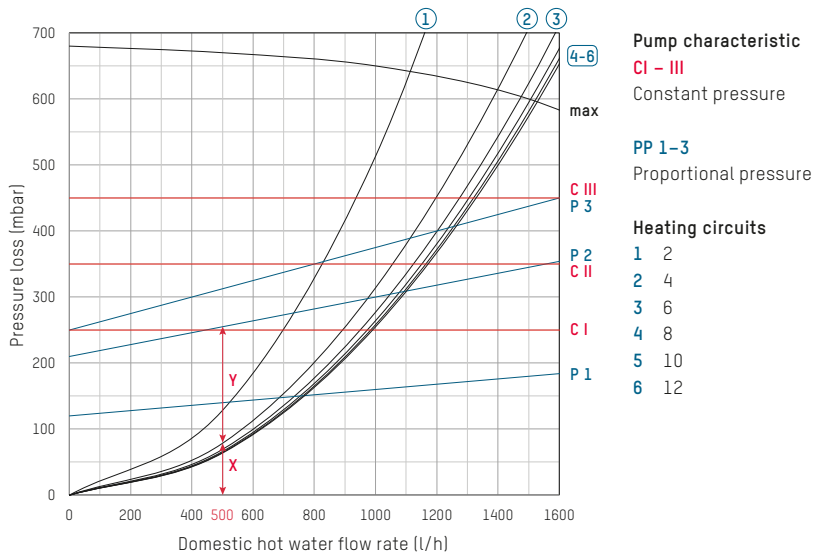

X = Distributor pressure drop (example: 4 heating circuits at 500 l/h)

Y = Heating circuit pressure drop

Mixing station settings

- 1 Calculate the required flow rate.
- 2 Add the pressure drop (x) to the corresponding distributor curve and the required pressure drop of the heating circuits (y).
- 3 Adjusting the pump using the pump graph
 - without zone control: constant pressure (CI-III) or proportional pressure (P1-3)
 - with zone control: proportional pressure (P1-3) or activeADAPT

SPECIFICATION TEXT

See www.taconova.com

TECHNICAL DATA

General

- Max. operating pressure $P_{0\ max}$: 3 bar
- Max. operating temperature $T_{0\ max}$: 70 °C
- Dimensions: W 874 mm × H 772 – 892 mm × D 110 mm
- Weight (empty): 30 kg

Materials

- Galvanized or varnished sheet steel housing according to model
- Pipes: DN 20 stainless steel 1.4404
- Pumps: cast iron
- Valve housing: brass
- Seals: AFM34 (flat sealing)

Performance data

See design diagram

Electrical connection data

- Mains voltage: 230 VAC ± 10 %
- Mains frequency: 50...60 Hz
- Power consumption: max. 4 - 60 W
- Protection type: IP 30
- EEI ≤ 0,20 – Part 2

Flow media

- Heating water (VDI 2035; SWKI BT 102-01; ÖNORM H 5195-1)
- Cold water as per DIN 1988-200 and DIN EN 806-5

Fittings dependent on model

- High-efficiency circulating pump: TacoFlow2 ADAPT
- 3-way mixing valve with fixed-value control
- Underfloor heating circuit manifold TacoSys 2-12 heating circuits
- Electro-thermal actuators
- NovaMaster connector module
- Electronic controller with display
- PICV valve

TYPE OVERVIEW

TacoSys Piko | Heating module with 10 heating circuits

Order no.	DN	Rp	Heating circuit connections	Measuring range Supply TopMeter
276.0022.139	20	1" OT	¾" OT	0 – 5 l/min

DIMENSIONAL DRAWING

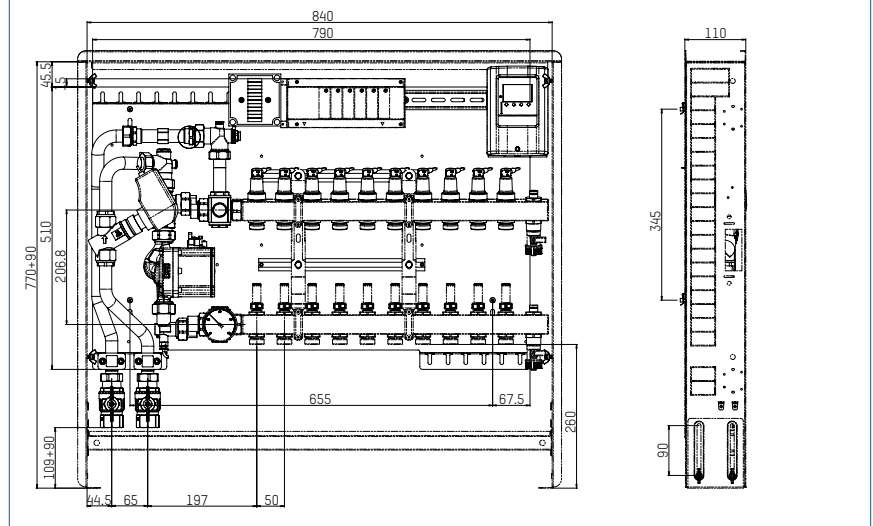

FLOW AND PRESSURE LOSS DIAGRAMS

For heating module with mixing station and fixed-value control and with open TopMeters and valves. Pump: TacoFlow2 ADAPT

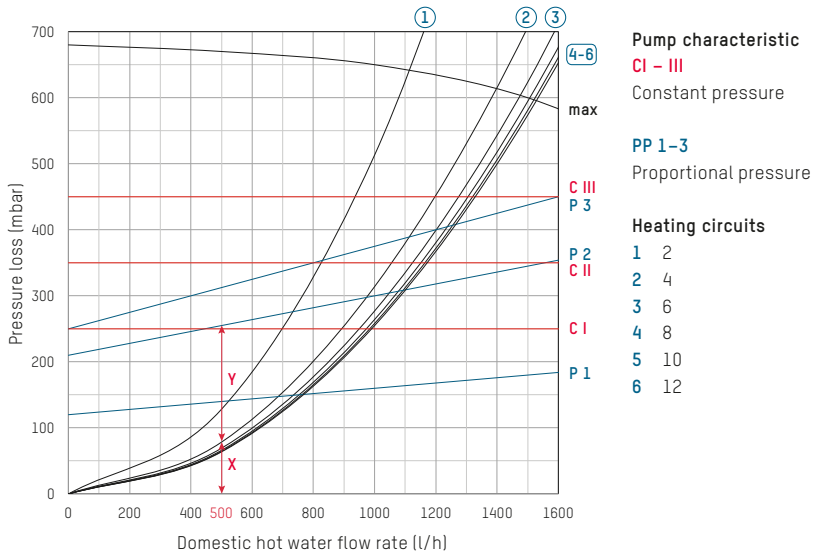

X = Distributor pressure drop (example: 4 heating circuits at 500 l/h)

Y = Heating circuit pressure drop

Mixing station settings

- 1 Calculate the required flow rate.
- 2 Add the pressure drop (x) to the corresponding distributor curve and the required pressure drop of the heating circuits (y).
- 3 Adjusting the pump using the pump graph
 - without zone control: constant pressure (CI-III) or proportional pressure (P1-3)
 - with zone control: proportional pressure (P1-3) or activeADAPT

SPECIFICATION TEXT

See www.taconova.com

TECHNICAL DATA

General

- Max. operating pressure $P_{0\max}$: 3 bar
- Max. operating temperature $T_{0\max}$: 70 °C
- Dimensions: W 874 mm × H 772 – 892 mm × D 110 mm
- Weight (empty): approx. 25 kg

Materials

- Galvanized or varnished sheet steel housing according to model
- Pipes: DN 20 stainless steel 1.4404
- Pumps: cast iron
- Valve housing: brass seals: AFM34 (flat sealing)

Performance data

See design diagram

Electrical connection data

Actuator

- Protection type: IP 40
- Electrical protection class II
- Rated voltage (AC or DC): 24 V or 230 V
- Permitted ambient temperature: ±10 %
- Operating efficiency: 1.8 W
- Inrush current:
 - 24 V: 0.2 A for max. 1 min
 - 230 V: 0.6 A for max. 100 ms
- Recommended fuse: 0.35A slow-acting, as per DIN 41662
- Connecting cable length: 1 m

Flow media

- Heating water (VDI 2035; SWKI BT 102-01; ÖNORM H 5195-1)
- Cold water as per DIN 1988-200 and DIN EN 806-5

Fittings dependent on model

- Underfloor heating circuit manifold TacoSys 2-12 heating circuits
- Electro-thermal actuators
- NovaMaster connector module
- Electronic controller with display
- PICV valve

TYPE OVERVIEW

TacoSys Piko | Heating module with 10 heating circuits (2-pipe system)

Order no.	DN	Rp	Heating circuit connections	Measuring range Supply TopMeter
276.0002.139	20	1" OT	¾" OT	0 – 5l/min

DIMENSIONAL DRAWING

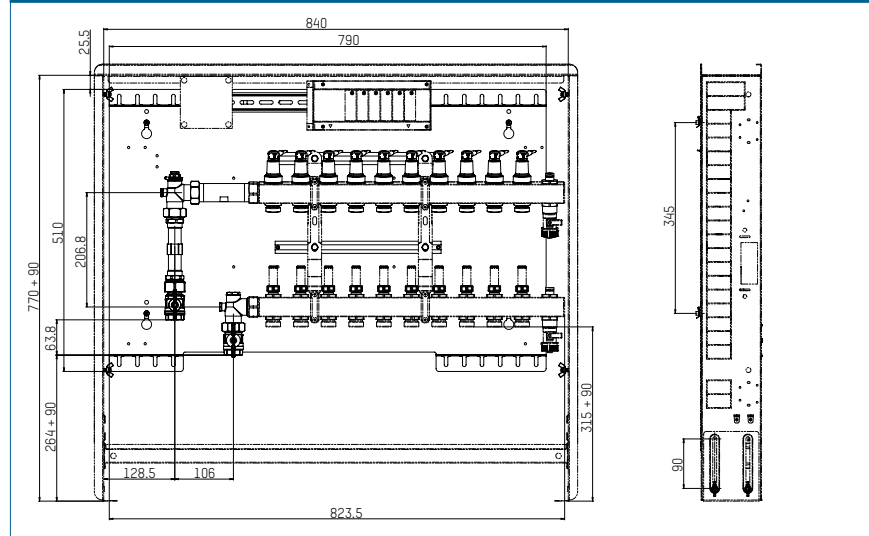

PRESSURE LOSS-DIAGRAMM

For TacoSys HighEnd heating circuit manifold with TopMeter Supply (0 – 5l/min; $k_{vs} = 0.97$)

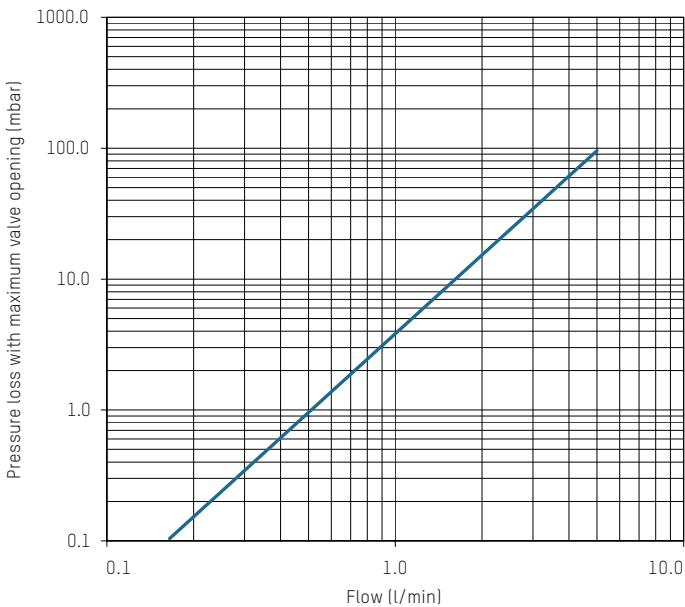

TACOTHERM FRESH/DUAL NANO

GAS BOILER REPLACEMENT AND HEAT INTERFACE UNIT



ADVANTAGES

- Slimline design
- Large number of variants
- Preconfigured for simple installation
- On-demand, hygienic, decentralised DHW heating
- Reduction of stored DHW volume to a minimum
- Demand-driven calculation of energy costs
- Use as a gas boiler replacement unit (TacoTherm Fresh Nano)

Preconfigured heat interface unit in slimline design for preparation of potable hot water and apartment heating.

DESCRIPTION

This heat interface unit in the Nano series suits practically any installation situation thanks to its slimline design and versatile constructions. The unit is available as an individual fresh hot water module as well as with integrated panel heating manifold.

Various selectable hydraulic components ensure on-demand preparation of potable hot water, distribution of heat energy as well as demand-driven calculation of energy costs.

INSTALLATION

The TacoTherm Dual Nano heat interface unit is installed as the base station on a base plate. Models are available for flush or surface mounting.

The TacoTherm Fresh Nano fresh hot water station is available in the surface-mounted model with a high-quality device enclosure. This station is designed for replacement of gas boilers in addition to other applications.

OPERATION

The heat interface unit in the Nano series is designed for preparation of potable hot water and distribution of heat energy in multistory residential buildings. The primary energy supply is by means of a centralized storage tank, while the drinking water is heated on demand in the fresh hot water module in accordance with the continuous flow principle. In the case of the combination station, radiators or underfloor heating systems in the apartments are connected to the integrated connections. The combination station meets the heat requirement for the apartment in this way.

The heating flow temperature is regulated on a fixed-value or weather-controlled basis. Adjusting pieces are provided in the modules for on-site installation of heat meters and cold water meters.

BUILDING CATEGORIES

- Apartment blocks
- Hotels and residential homes
- Industrial buildings

SYSTEM/BASIC DIAGRAM

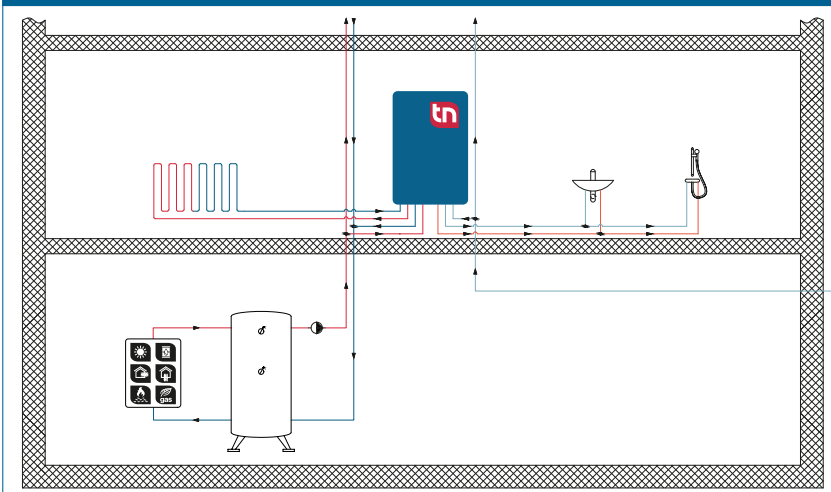

SPECIFICATION TEXT

See www.taconova.com

TECHNICAL DATA FOR FRESH HOT WATER MODULE

General

- Max. operating temperature $T_{0\ max}$: 95 °C
- Max. operating pressure $P_{0\ max}$:
 - Primary: 3 bar
 - Secondary: 6 bar
- Dimensions on base plate:
 - Variant 1: W 435 mm × H 634 mm × D 132 mm
* D 150 mm with differential pressure controller
 - Variant 2: W 490 mm × H 634 mm × D 132 mm
* D 150 mm with differential pressure controller
 - Variant for gas boiler replacement and device enclosure: B 450 mm × H 635 mm × D 156 mm
- Weight (empty): 35 kg

Materials

- Plate heat exchanger (plates and connector pieces): copper soldered / nickel soldered
- Galvanized or varnished sheet steel housing according to model
- Pipes: DN 20 Stainless steel 1.4404
- Valve housing: Brass
- Seals: AFM34 (flat sealing)

Performance data

See design diagram

Flow media

- Heating water (VDI 2035; SWKI BT 102-01; ÖNORM H 5195-1)
- Cold water according to DIN 1988-200 and DIN EN 806-5

APPROVALS / CERTIFICATES

- Components in contact with potable water comply with UBA Evaluation Criteria 26/03/2018 and Directive (EU) 2015/1535

TYPE OVERVIEW

TacoTherm Fresh Nano | Fresh Hot Water Station * 1)

Order no.	DN	Rp	Dispensing range * 2)	Heat exchanger
276.1258.000	20	1" OT	up to 20 l/min (39KW)	Copper-soldered 24 plates

* 1) Any matching accessories required can be individually selected

* 2) Performance data for primary = flow 60 °C / Secondary = hot water 45 °C; $\Delta p \geq 300$ mbar

DIMENSIONAL DRAWING

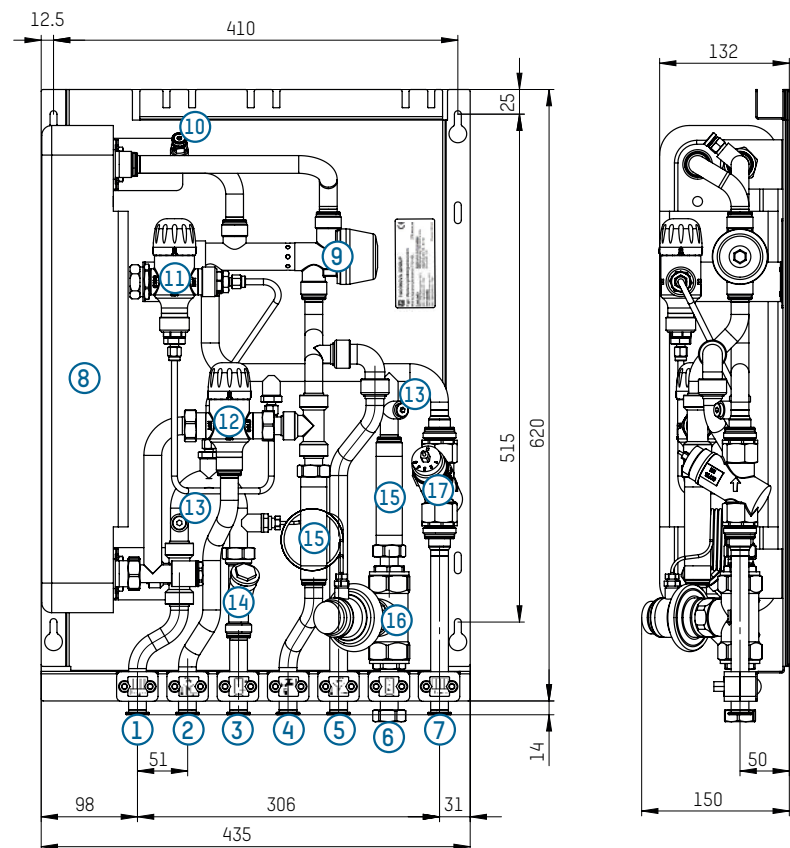

- | | |
|-------------------------------------------------------|----------------------------------------------------------------------------------------|
| 1 Connection for heat distribution on supply side | 8 Heat exchanger |
| 2 Connection for drinking water distribution (hot) | 9 Proportional flow controller |
| 3 Primary connection for heat supply on supply side* | 10 Venting |
| 4 Connection for main supply line for drinking water* | 11 Standby module (optional) |
| 5 Connection for drinking water distribution (cold) | 12 NovaMix Value thermal mixing valve as anti-scald protection (optional, recommended) |
| 6 Primary connection for heat supply on return side* | 13 Sensor seats |
| 7 Connection for heat distribution on return side | 14 Dirt filter |
| | 15 Meter adjusting pieces |
| | 16 Dynamic differential pressure controller (optional) |
| | 17 Dynamic mass flow controller or TacoSetter Inline (optional) |

* top connection available optionally, see hydraulic diagram

ACCESSORIES

CONNECTION RAIL WITH BALL VALVES FOR TACOTHERM FRESH NANO

Order no.	DN	Rp	Number of ball valves
296.3004.000	20	¾" IT × 1" OT	7

FLOW DIAGRAM

Fresh water module (connections at bottom)

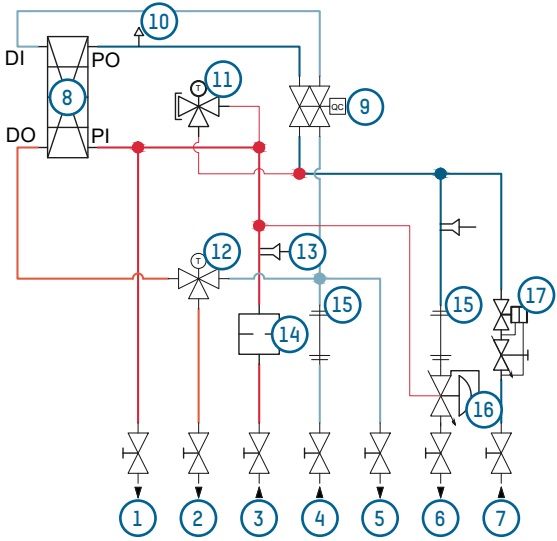

Key

- 1 Connection for heat distribution on supply side
- 2 Connection for drinking water distribution (hot)
- 3 Primary connection for heat supply on supply side
- 4 Connection for main supply line for drinking water
- 5 Connection for drinking water distribution (cold)
- 6 Primary connection for heat supply on return side
- 7 Connection for heat distribution on return side
- 8 Heat exchanger
- 9 Proportional flow controller
- 10 Venting
- 11 Standby module (optional)
- 12 Thermal mixing valve NovaMix Value as anti-scald protection (optional, recommended)
- 13 Sensor seats
- 14 Dirt filter
- 15 Meter adjusting pieces
- 16 Dynamic differential pressure controller (optional)
- 17 Dynamic mass flow controller (optional)

Fresh water module (supply connections at top)

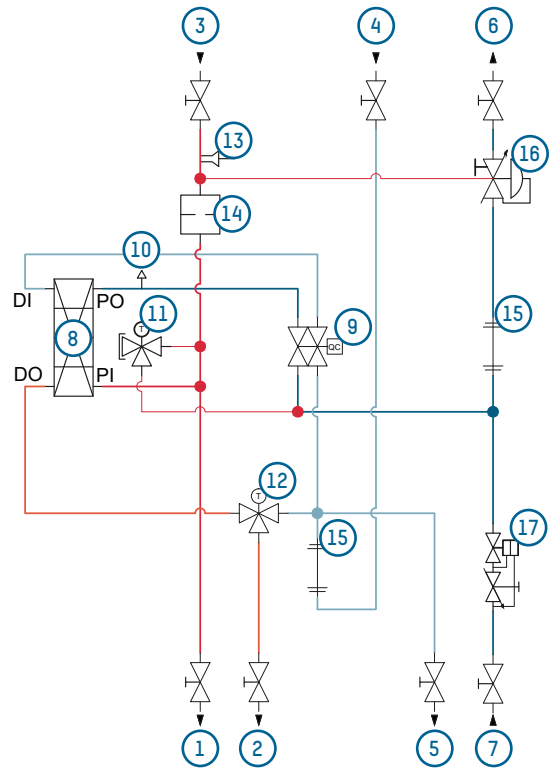

**FLOW AND PRESSURE LOSS DIAGRAMS
PLATE HEAT EXCHANGER WITH 24 PLATES**

Pressure loss on secondary side

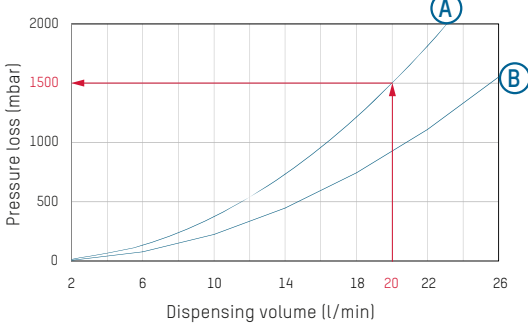

E) Domestic hot water demand / Dispensing volume

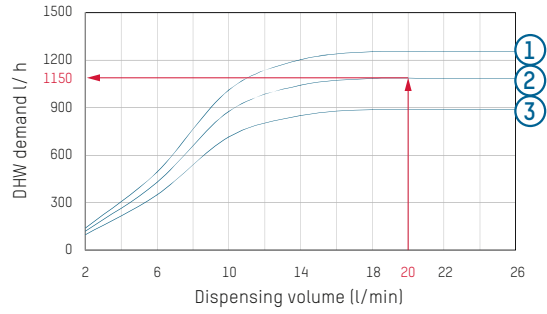

B) Domestic hot water temperature = 70 °C

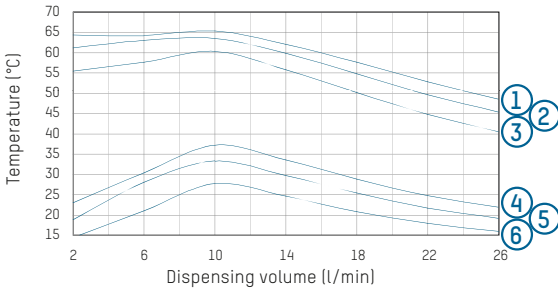

F) Domestic hot water temperature = 65 °C

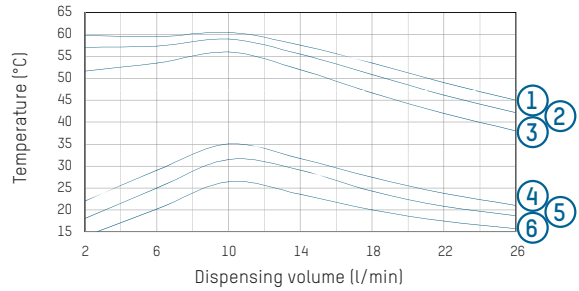

C) Domestic hot water temperature = 60 °C

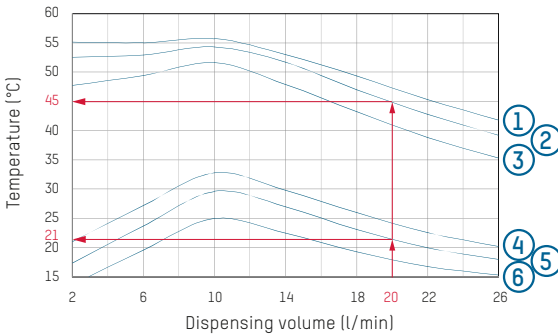

G) Domestic hot water temperature = 55 °C

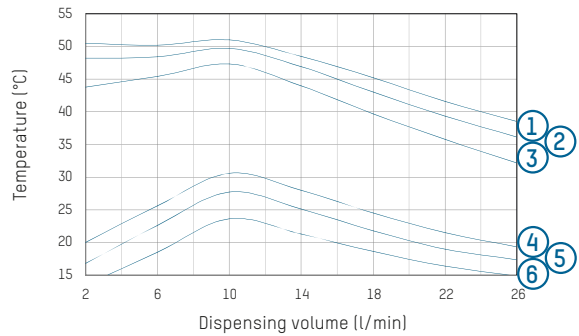

D) Domestic hot water temperature = 50 °C

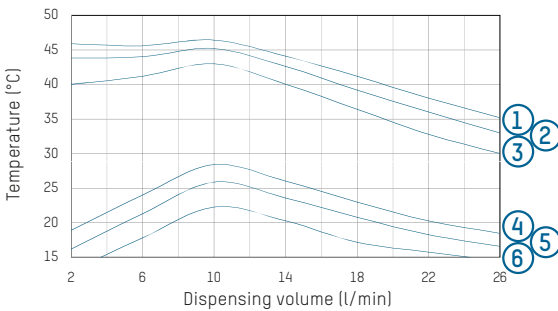

- A k_{vs} Secondary with mixing valve
- B k_{vs} Secondary without mixing valve
- 1 Dispensing temperature [°C] for Δp 400 mbar
- 2 Dispensing temperature [°C] for Δp 300 mbar
- 3 Dispensing temperature [°C] for Δp 200 mbar
- 4 Return temperature [°C] for Δp 400 mbar
- 5 Return temperature [°C] for Δp 300 mbar
- 6 Return temperature [°C] for Δp 200 mbar

EXAMPLE OF INTERPRETING THE FLOW RATE AND PRESSURE LOSS DIAGRAMS

Given

- Hot water dispensing volume: 20 l/min
- Primary heating flow temperature: 60 °C
- Available differential pressure: 300 mbar

Sought

- Domestic hot water demand in l/h

- Pressure loss on secondary side
- Dispensing temperature Primary heating return temperature in °C
- Secondary pressure loss in mbar

Approach

- In Diagram C) the hot water dispensing temperature of 45 °C and the associated return temperature can be read for the given hot water dispensing volume of 20 l/min at the

intersection point with the differential pressure of 300 mbar.

- Diagram A) shows the pressure loss in the system on the secondary side and Diagram E) shows a domestic hot water demand of 1150 l/h at the intersection point between the dispensing temperature and the 300 mbar differential pressure.

**FLOW AND PRESSURE LOSS DIAGRAMS
PLATE HEAT EXCHANGER WITH 40 PLATES**

A) Pressure loss on secondary side

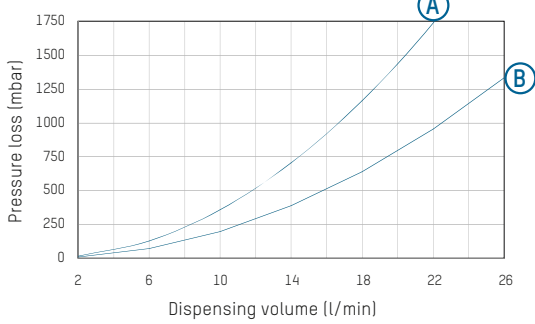

E) Domestic hot water demand / Dispensing volume

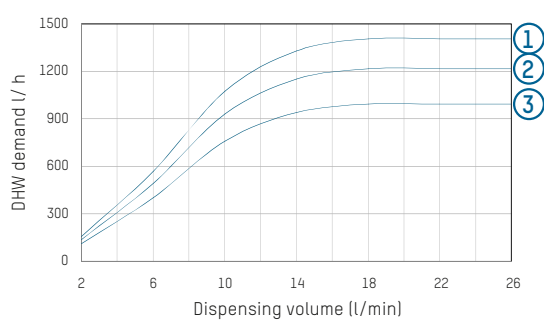

B) Domestic hot water temperature = 70 °C

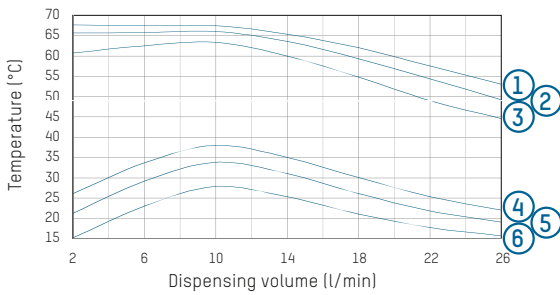

F) Domestic hot water temperature = 65 °C

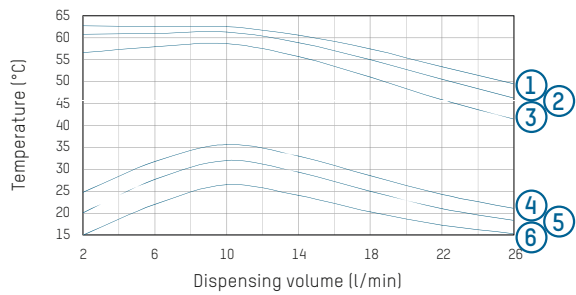

C) Domestic hot water temperature = 60 °C

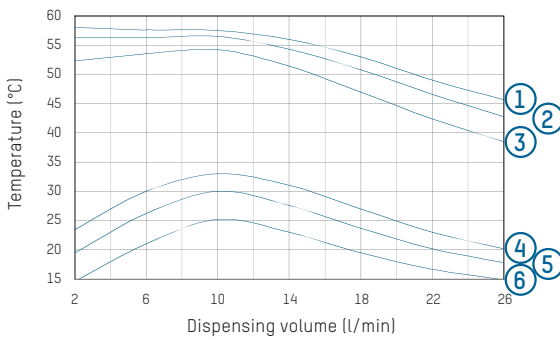

G) Domestic hot water temperature = 55 °C

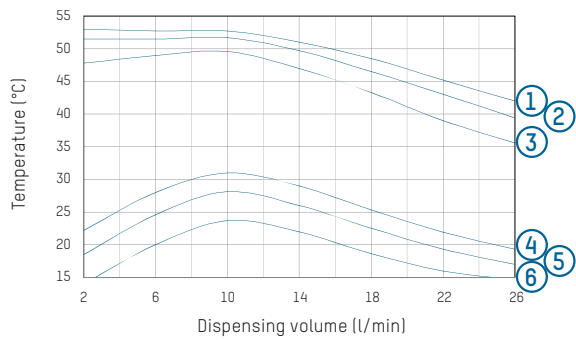

D) Domestic hot water temperature = 50 °C

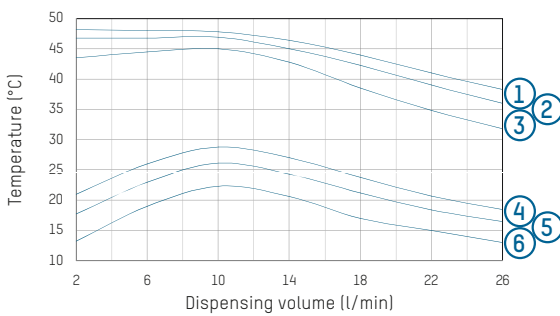

- A** k_{vs} Secondary with mixing valve
- B** k_{vs} Secondary without mixing valve
- 1** Dispensing temperature (°C) for Δp 400 mbar
- 2** Dispensing temperature (°C) for Δp 300 mbar
- 3** Dispensing temperature (°C) for Δp 200 mbar
- 4** Return temperature (°C) for Δp 400 mbar
- 5** Return temperature (°C) for Δp 300 mbar
- 6** Return temperature (°C) for Δp 200 mbar

SPECIFICATION TEXT

See www.taconova.com

TECHNICAL DATA FOR COMBINATION STATION

General

- Max. operating temperature $T_{0\ max}$:
 - Fresh water module: 95 °C
 - Heating manifold: 70 °C
- Max. operating pressure $P_{0\ max}$:
 - Primary: 3 bar
 - Secondary: 6 bar
- Weight (empty): 65 kg
- Dimensions in mounting frame
 - Variant with up to 8 heating circuits:
W 634 × H 1273 (+90) × D 153 mm
 - Variant with up to 10 heating circuits:
W 749 × H 1273 (+90) × D 153 mm

Materials

- Plate heat exchanger (plates and connector pieces): copper soldered / nickel soldered
- Galvanized or varnished sheet steel housing according to model
- Valve housing: Brass
- Pipes: DN 20 Stainless steel 1.4404
- Seals: AFM34 (flat sealing)

Features of heating module

- Circulating pump: Grundfos UPM 3 15-70 Hybrid
- Heating manifold 2 – 8 heating circuits (9 - 10 on request)
- Supply TopMeter
- Thermal actuators (optional)
- Fixed-value or weather-controlled heating module regulation

Performance data

See design diagram

Electrical connection data

- Mains voltage: 230 VAC ± 10 %
- Mains frequency: 50...60 Hz
- Power consumption: max. 4 – 60 W
- Protection type: IP 30

Flow media

- Heating water (VDI 2035; SWKI BT 102-01; ÖNORM H 5195-1)
- Cold water as per DIN 1988-200 and DIN EN 806-5

APPROVALS / CERTIFICATES

- Components in contact with potable water comply with UBA Evaluation Criteria 26/03/2018 and Directive (EU) 2015/1535

TYPE OVERVIEW

TacoTherm Dual Nano | Combination station with 10 heating circuits * 1)

Order no.	DN	Rp	Dispensing range * 2)	Heat exchanger
276.2571.137	20	¾" IT	up to 20 l/min (39KW)	Copper-soldered 24 plates

* 1) Any matching accessories required can be individually selected

* 2) Performance data for primary = flow 60 °C / Secondary = hot water 45 °C; $\Delta p \geq 300$ mbar

DIMENSIONAL DRAWING

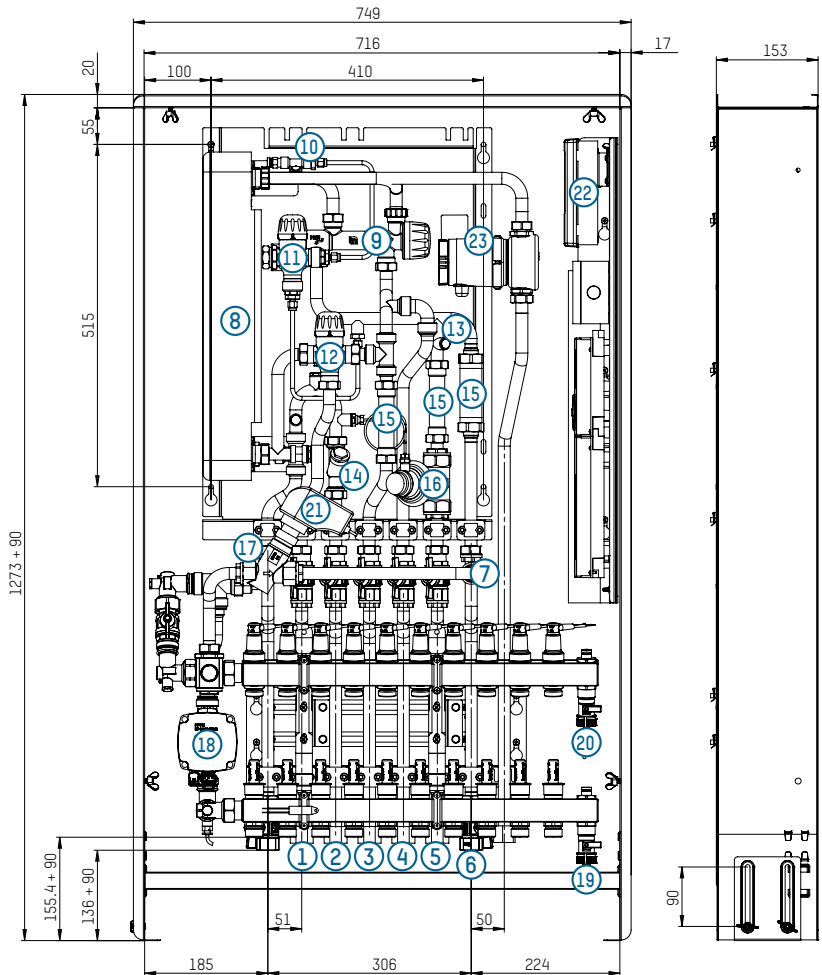

- | | |
|------------------------------------------------------|-----------------------------------------------------------------------------------------------------|
| 1 Connection for heat distribution on supply side | 12 Thermostatic mixing valve NovaMix Value thermal as anti-scald protection (optional, recommended) |
| 2 Connection for drinking water distribution (hot) | 13 Sensor seats |
| 3 Primary connection for heat supply on supply side | 14 Dirt filter |
| 4 Connection for main supply line for drinking water | 15 Meter adjusting pieces |
| 5 Connection for drinking water distribution (cold) | 16 Dynamic differential pressure controller (optional) |
| 6 Primary connection for heat supply on return side | 17 Dynamic mass flow controller (optional) |
| 7 Connection for heat distribution on return side | 18 Circulating pump |
| 8 Heat exchanger | 19 Supply manifold bar with TopMeter |
| 9 Proportional flow controller | 20 Return manifold bar with heating valves and actuators (optional) |
| 10 Venting | 21 Weather-controlled actuator (optionally fixed-value controlled) |
| 11 Standby module (optional) | 22 Controller |
| | 23 Circulating pump |

FLOW DIAGRAM

Heating control:
Fixed-value or weather-controlled
Connection for 2-pipe system

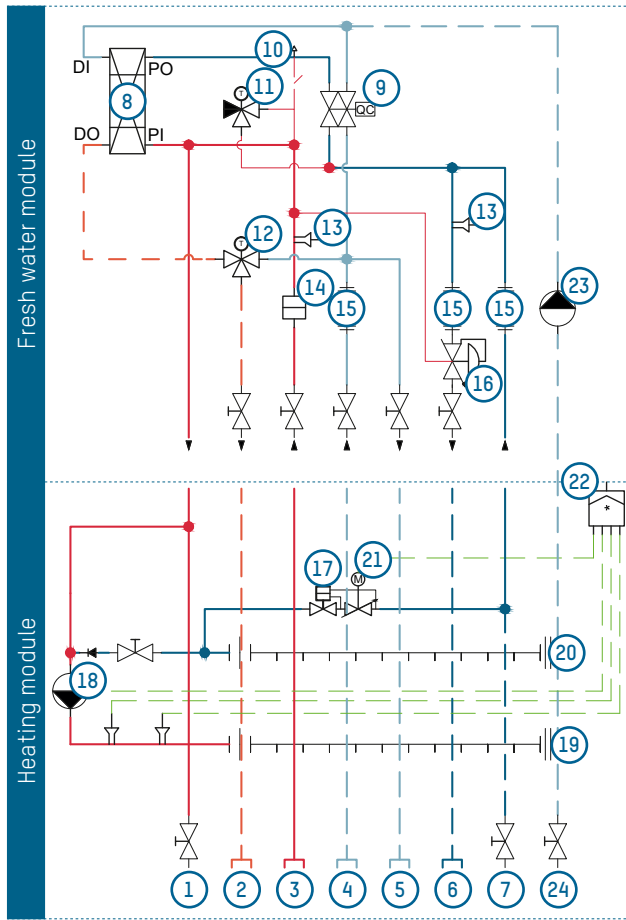

Heating control:
Fixed-value or weather-controlled
Connection for 4-pipe system

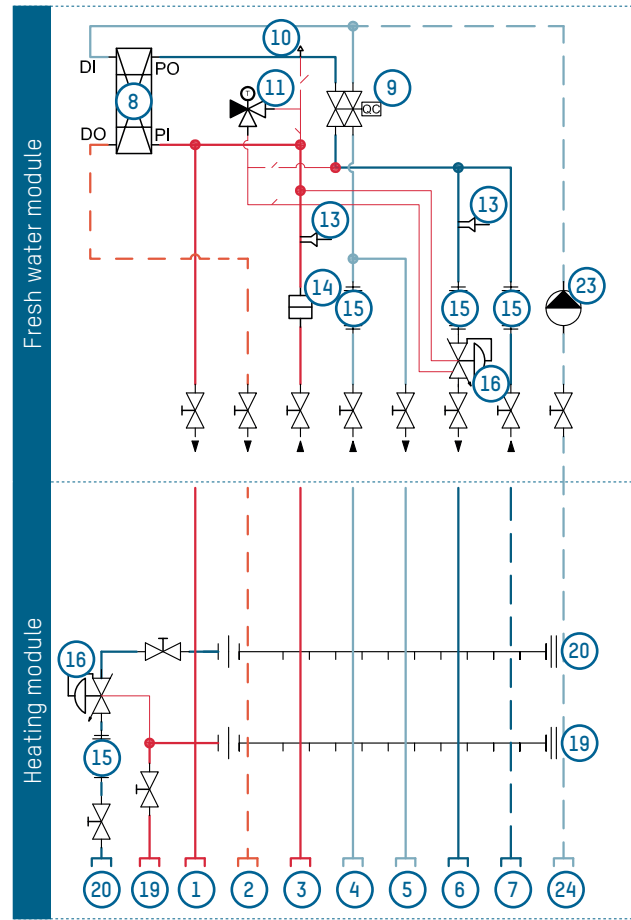

Key

- | | |
|--------------------------------------------------------------------------------------------------------------------------------------------------------------------------------------------------------------------------------------------------------------------------------------------------------------------------------------------------------------------------------------------------------------------------------------------------------------------------------------------------------------------------------------------------------------------------------------------------------------------------------------------------------------------------------------------------------------------------------------|-------------------------------------------------------------------------------------------------------------------------------------------------------------------------------------------------------------------------------------------------------------------------------------------------------------------------------------------------------------------------------------------------------------------------------------------------------------------------------------------------------------------------------------------------------------------------------------------|
| <ul style="list-style-type: none"> 1 Connection for heat distribution on supply side 2 Connection for drinking water distribution (hot) 3 Primary connection for heat supply on supply side 4 Connection for main supply line for drinking water 5 Connection for drinking water distribution (cold) 6 Connection for heat distribution on return side 7 Primary connection for heat supply on return side 8 Heat exchanger 9 Proportional flow controller 10 Venting 11 Standby module (optional) 12 NovaMix Value thermal mixing valve as anti-scald protection (optional, recommended) 13 Sensor seats | <ul style="list-style-type: none"> 14 Dirt filter 15 Meter adjusting pieces 16 Dynamic differential pressure controller (optional) 17 Dynamic mass flow controller (optional) 18 Circulating pump 19 Supply manifold bar with TopMeter 20 Return manifold bar with heating valves and actuators (optional) 21 Weather-controlled actuator (optionally fixed-value controlled) 22 Controller weather-controlled regulation 23 Circulating pump 24 Connection for circulating pump |
|--------------------------------------------------------------------------------------------------------------------------------------------------------------------------------------------------------------------------------------------------------------------------------------------------------------------------------------------------------------------------------------------------------------------------------------------------------------------------------------------------------------------------------------------------------------------------------------------------------------------------------------------------------------------------------------------------------------------------------------|-------------------------------------------------------------------------------------------------------------------------------------------------------------------------------------------------------------------------------------------------------------------------------------------------------------------------------------------------------------------------------------------------------------------------------------------------------------------------------------------------------------------------------------------------------------------------------------------|

FLOW, TEMPERATURE AND PRESSURE LOSS DIAGRAMS

See diagrams for TacoTherm Fresh Nano on Page 5 + 6

FLOW AND PRESSURE LOSS DIAGRAMS

Proportional pressure controlled pump

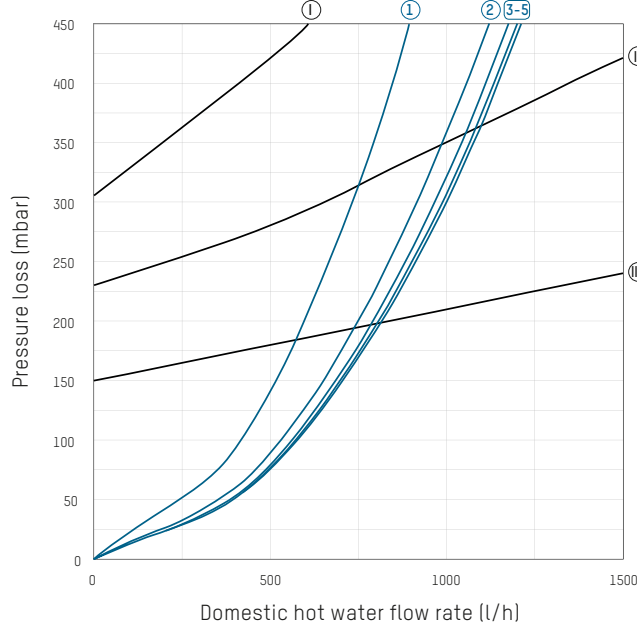

Number of heating circuits

- 1 2
- 2 4
- 3 6
- 4 8
- 5 10

Pump characteristic Grundfos UPM

- I 1
- II 2
- III 3

Constant pressure controlled pump

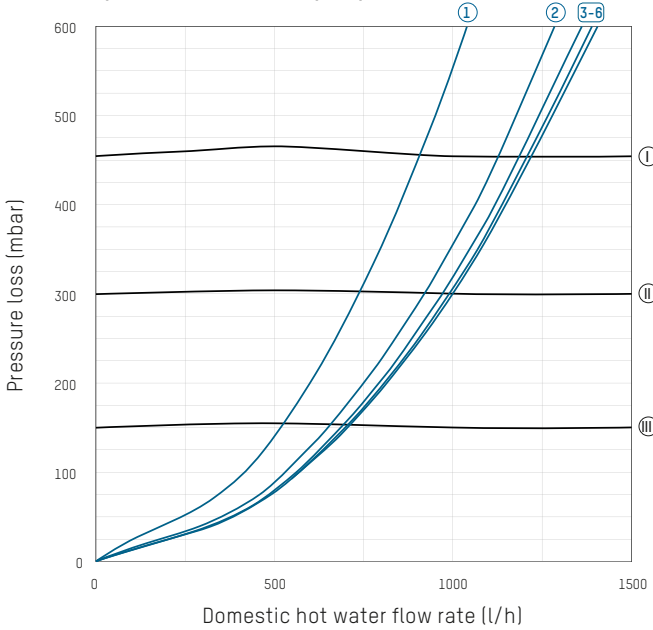

Number of heating circuits

- 1 2
- 2 4
- 3 6
- 4 8
- 5 10
- 6 12

Pump characteristic Grundfos UPM

- I 1
- II 2
- III 3

EXAMPLE OF CALCULATING THE AVAILABLE PUMP HEAD FOR DESIGNING THE CONNECTED HEATING SURFACES

Given

- Required domestic hot water flow rate: 1000 l/h
- Panel heating manifold: 6 heating circuits

Sought

- Available pump head (a) of pump for heating surfaces to be connected
- Secondary pressure loss in mbar

Approach

- Characteristic 3 and a DHW flow rate of 1000 l/h gives rise to a manifold pressure loss of 150 mbar.
- Pump Position 7 and proportional pressure control gives rise to a max. pump pressure of 425 mbar

Result

- The available pump head (a) of 275 mbar is derived from the difference between the max. pump pressure (425 mbar) and the manifold pressure loss (150 mbar)

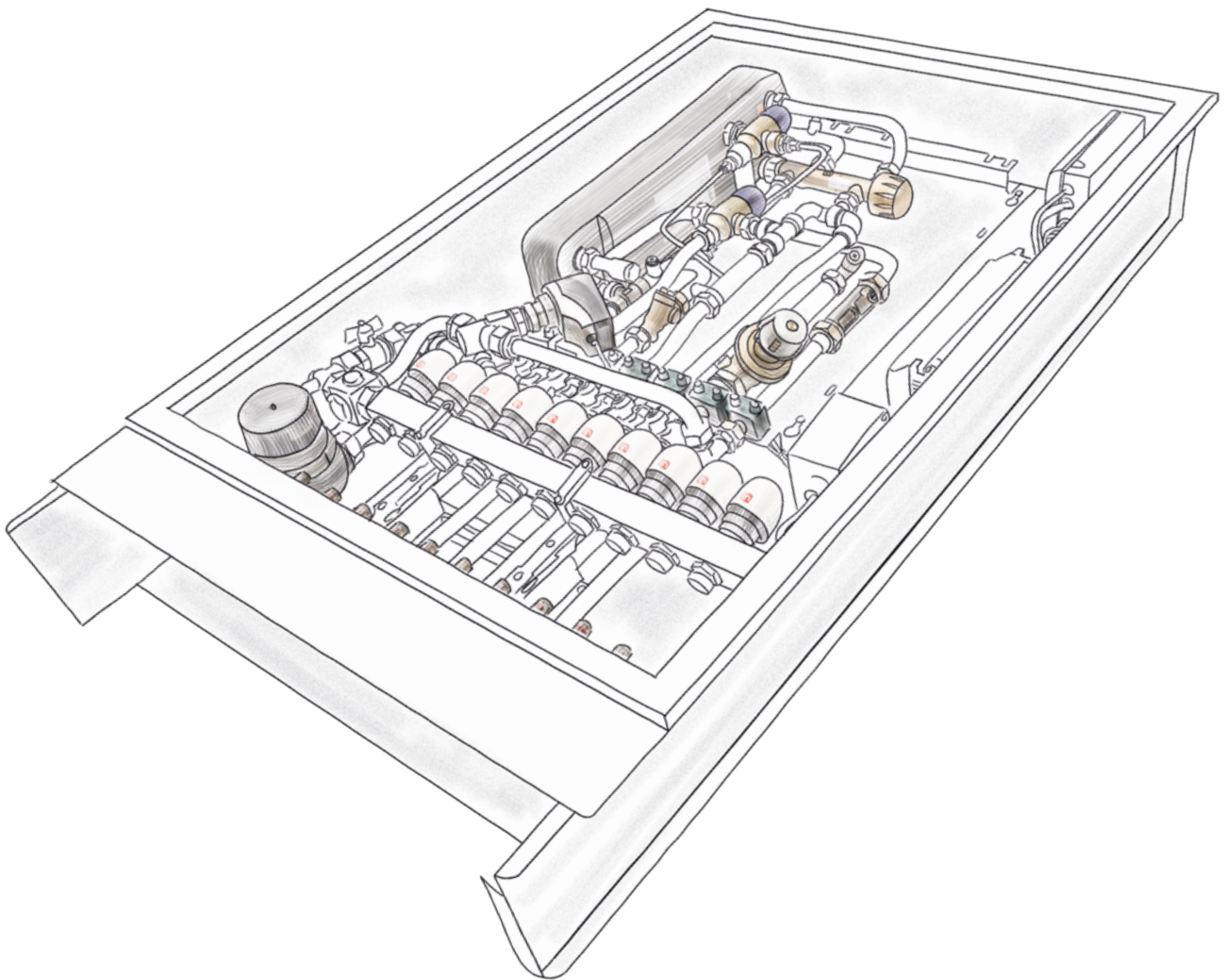

HOT WATER AS AND WHEN YOU NEED IT

Centralized and decentralized preparation of domestic hot water in accordance with the continuous flow principle offers the advantage of on-demand supply without prior storage of domestic hot water, thus providing effective protection against Legionella bacteria.

HYGIENIC HOT DRINKING WATER

Good quality drinking water is fundamental to our nutritional needs. Legislators have set down principles in this regard in a variety of ordinances and directives. Replacing drinking water storage units with fresh water stations ensures the needs-based heating of drinking water and the associated hygienic requirements. In addition, such systems provide reliable protection against scalding and ensure the best possible use of the available energy source.

HEATING DRINKING WATER WITH FRESH WATER STATIONS

A larger quantity of heated drinking water is stored for supply in domestic hot water storage tanks. Such volumes must be stored at a constant temperature of >60°C to avoid the risk of germ formation. Should technical problems arise in the system, however, this leads to an increased hygiene risk owing to the large volume. Fresh hot water stations only heat the drinking water immediately on demand and thus avoid the hygiene problems that come with storage. The thermal energy required is drawn directly from a storage tank or stratified storage unit and the process water contained within. The user is protected against scalding at the same time thanks to the electronic regulation of the outlet temperature.

CAN BE COMBINED WITH ANY ENERGY SYSTEM

The use of thermal energy from a storage tank means that the decentralized heating of drinking water does not depend on the way in which heat is generated: The storage tank can be loaded by means of solar energy, gas or oil-fueled burners, pellet or wood-burning boilers or heat pumps.

The TacoTherm Fresh Mega3 and Peta2 station variants also offer the option of integrating the station with the building control system via an interface.

DECENTRALIZED HEATING OF DRINKING WATER FOR RESIDENTIAL CONSTRUCTION

Using the fresh hot water and home station means that there is no need for large central drinking water storage systems and thus minimizes the technical measures needed to protect against Legionella.

In order to cater for the hot water requirements of individual residential units, TacoNova has added the TacoTherm Dual Piko and Nano transfer stations to its range, enabling the decentralized supply of hot water in residential buildings.

HIGH HOT WATER OUTPUT IN COMMERCIAL PROPERTIES

In commercial buildings, such as sports halls, high simultaneous drawing of domestic hot water is to be expected. For these applications, the TacoTherm Fresh Mega3 and Peta2 product versions can be installed in a cascade. The number of units in this case also ensures excellent fail-safe reliability for heating drinking water. The solar heat stored in the storage tank is thus also available to support the heating process, enhancing efficiency.

OPTIMUM USE OF SPACE

The compact design of the fresh water station outside the solar storage unit and storage tank means that there is no need for a hot drinking water storage tank and the additional space available can be used to add more or bigger storage tanks.

THE LINK BETWEEN THE STORAGE TANK AND THE DISPENSING POINT

Fresh water stations heat up drinking water as and when needed using any storage tank.

BENEFITS AT THE PLANNING STAGE

- Simplified planning of low-temperature heating systems while at the same time ensuring the quality of the domestic hot water
- Modules and materials approved for drinking water
- Efficient planning thanks to hydraulic design and station configuration by the manufacturer



BENEFITS AT THE INSTALLATION STAGE

- Less time required to install, commission and maintain the system
- Service and guarantee from a single source
- Reliable operation thanks to high-quality components
- Easier to provide proof of hot water quality

TacoTherm Fresh fresh hot water stations

Connection-ready fresh hot water stations for on-demand preparation of hot water in accordance with the continuous flow principle

- The required primary energy is obtained directly from the heating system storage tank
- No pre-storage of domestic hot water, which means water is not allowed to stagnate and effective protection is provided against Legionella

Product photo	Station / Type	Dispensing rate	Version
	TacoTherm Fresh Mega3	23 l/min*	<ul style="list-style-type: none"> ▪ With and without drinking water circulating pump ▪ With and without dual-zone stratification ▪ With ModBus RTU interface ▪ Cascadable
	TacoTherm Fresh Mega3 X	34 l/min*	
	TacoTherm Fresh Peta2	63 l/min*	
	TacoTherm Fresh Peta2 X	97 l/min*	

* Output levels at 70 °C primary temperature, domestic hot water heating from 10 °C to 60 °C and 100 mbar residual head. You will find information on the previous TacoTherm Fresh Mega, Tera and Exa stations on request.

BROCHURE CENTRAL DOMESTIC HOT WATER TECHNOLOGY (HIU)



TACOTHERM FRESH MEGA3 (C/CL)

FRESH HOT WATER STATION WITH HIGH-EFFICIENCY PUMPS



ADVANTAGES

Compact and versatile

- Models: with and without circulation pump, dual-zone return stratification
- Cascading possible

Secure

- Integration in building control system via optionally available eLink ModBus RTU interface
- Integrated safety subassembly and soft-close valves

Simple

- Valves and components are fully preassembled and ready for connection

Efficient

- Simple and fast commissioning

Fresh hot water station for hygienically heating drinking water in accordance with the continuous flow principle with innovative regulation technology

DESCRIPTION

The TacoTherm Fresh Mega3 (C/CL) fresh water station is used for on-demand preparation of domestic hot water in accordance with the continuous flow principle. It retrieves the heat from the storage tank of an existing or new heating system, which uses solid-fuel boilers, heat pumps, solar systems, etc. as a heat source. The station replaces the storage of hot drinking water and thus provides a high degree of protection against Legionella by avoiding water stagnation.

INSTALLATION POSITION

Vertical wall-mounting in the vicinity of the hot water storage tank or on the tank itself.

OPERATION

Drinking water is heated to the defined dispensing temperature in the TacoTherm Fresh Mega3 (C/CL) in accordance with the continuous flow principle. The integrated heat exchanger is supplied with as little hot water from the storage tank as is required to maintain a constant dispensing temperature.

The latest pump and regulation technology is used. In recording the temperature difference and flow rate data, the electronic regulator simultaneously records and stores the quantity of heat consumed.

In addition to an additional circulation pump that can be installed, the TacoTherm Fresh Mega3 (C/CL) can also be supplied with a switching valve for dual-zone return stratification.

The primary pump, circulation pump as well as load valve are controlled by the integrated regulator in accordance with specifications.

BUILDING CATEGORIES

- Apartment blocks
- Housing estates
- Multiple dwelling units
- Smaller public buildings
- Facilities with partial use – for example barracks, camping sites, etc.

SYSTEM/BASIC DIAGRAM

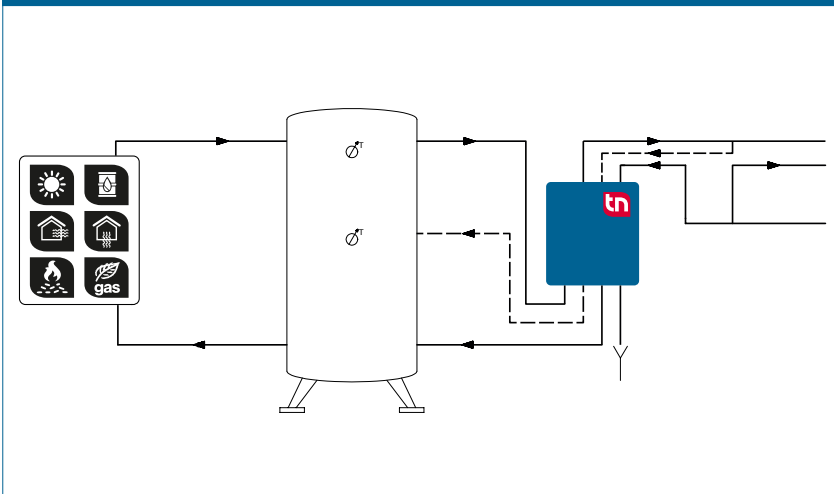

SPECIFICATION TEXT

See www.taconova.com

TECHNICAL DATA

General

- TacoTherm Fresh Mega3 controller
- Weight (empty): 17.5 – 20 kg
- Overall dimensions (incl. hood):
W 470 mm × H 685 mm × D 193 mm

Material

- Base plate: Galvanized sheet steel
- Rear panel and hood: EPP design insulation
- Pumps:
 - Primary: Cast steel
 - Secondary: PPS (plastic, approved for drinking water)
- Valve housing: Brass
- Pipes: DN 20 stainless steel 1.4404
- Plate heat exchanger:
 - Plates and connector pieces: Stainless steel 1.4401
 - Heat exchanger solder: 99.99 % copper (on request: stainless steel solder)
- Seals: AFM flush seal

Primary side

- Operating temperature $T_{0\max}$: 95 °C
- Operating pressure $P_{0\max}$: 6 bar
- Primary pump: TacoFlow3 GenS 15-85/130 C6 DS P

Secondary side

- Operating temperature $T_{0\max}$: 95 °C
- Operating pressure $P_{0\max}$: 10 bar
- Safety valve (intrinsic safety): 10 bar
- Circulation pump: TacoFlow2 Pure C 15-40/130 C6

Electrical connection data

- Mains voltage: 230 VAC ± 10 %
- Mains frequency: 50...60 Hz
- Power consumption: max. 250 W
- 3.5 AT fuse
- eBus interface
- Protection type: IP 40

Flow media

- Heating water (VDI 2035; SWKI BT 102-01; ÖNORM H 5195-1)

APPROVALS / CERTIFICATES

- Components in contact with potable water comply with UBA Evaluation Criteria 26/03/2018 and Directive (EU) 2015/1535
- SVGW: 1808-6783

TYPE OVERVIEW

TacoTherm Fresh Mega3 | Fresh hot water station

Order no.	Rp ¾"	Rp 1"	Version	Version
272.2026.000	⑤ ⑥	① ②		Without circulating pump, without dual-zone return stratification
273.2226.000	⑤ ⑥	① ③ ④	C	With circulating pump, without dual-zone return stratification
273.2229.000	⑤ ⑥	①-④	CL	With circulating pump and dual-zone return stratification

DIMENSIONAL DRAWING

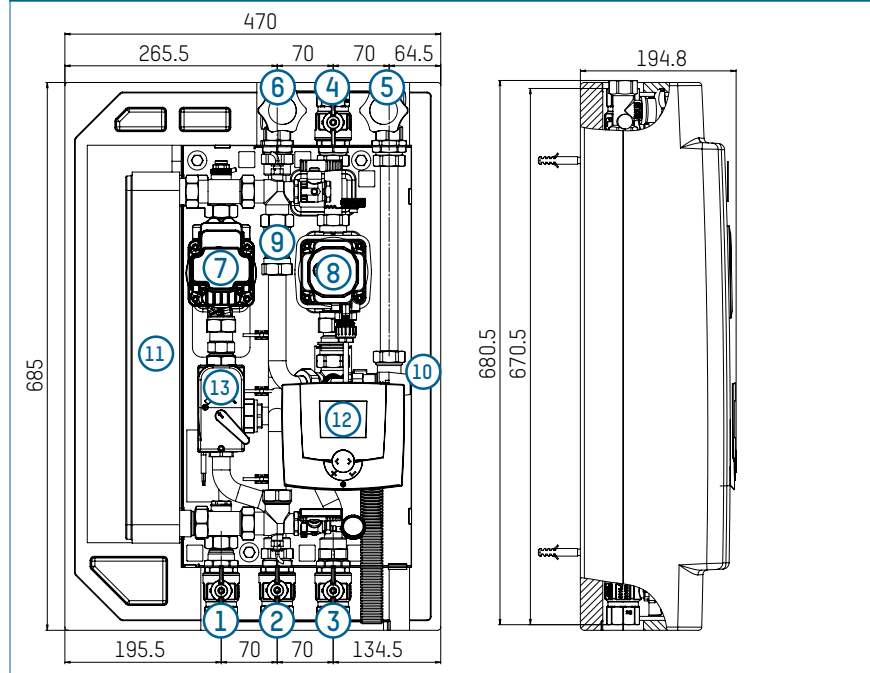

PRODUCT DIAGRAM

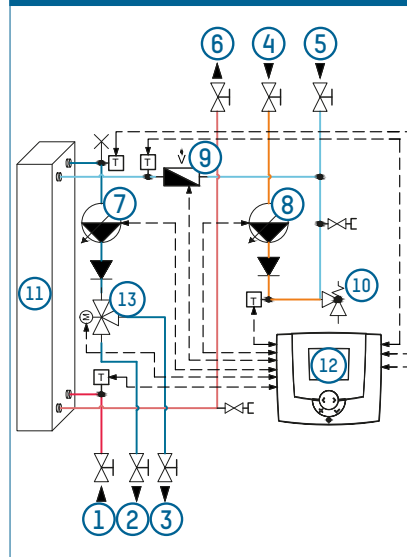

- 1 Primary hot water flow
- 2 Primary hot water return 1 (integration of storage tank in center in CL models)
- 3 Primary hot water return 2 (integration of storage tank below)
- 4 Circulation (C/CL version)
- 5 Cold water connection (¾")
- 6 Hot water connection
- 7 Primary pump
- 8 Circulation pump (C/CL version)
- 9 Flow rate sensor
- 10 Safety valve
- 11 Heat exchanger
- 12 Regulator
- 13 Switching valve (CL version)

**FLOW AND PRESSURE LOSS DIAGRAMS
COLD WATER HEATING AT 50K (10 ... 60 °C)**

D) Secondary pressure loss

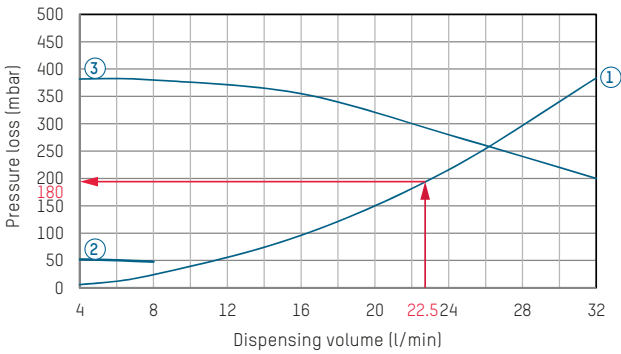

- 1 Pressure loss for cold water and circulation (secondary)
- 2 Circulation pump min
- 3 Circulation pump max
- 4 Primary pressure loss
- 5 Pump characteristic primary side

C) Return temperatures

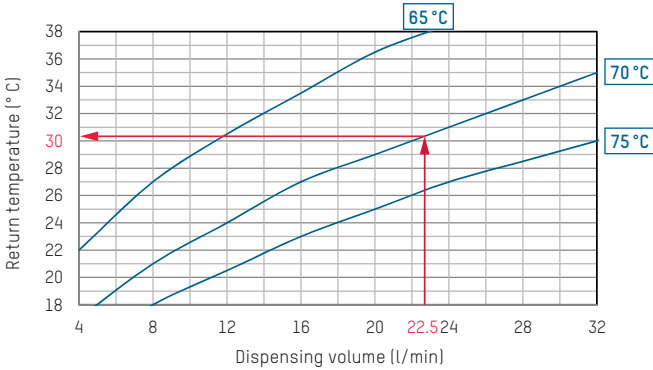

A) Cold water heating at 50K

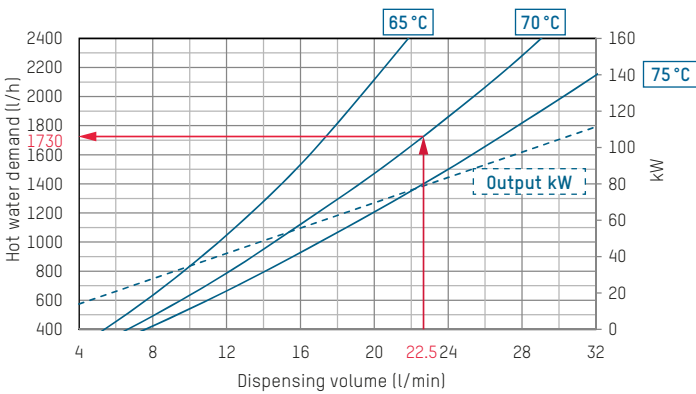

B) Residual head | Primary pressure loss

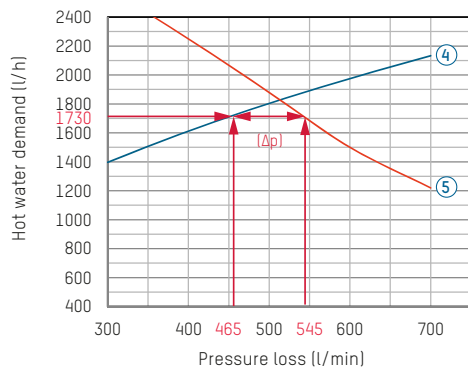

EXAMPLE FOR INTERPRETING THE FLOW RATE AND PRESSURE LOSS DIAGRAMS

Given

- Hot water dispensing volume: 22.5 l/min
- Primary heating flow temperature: 70 °C

Sought

- Hot water demand (l/h)
- Primary heating return temperature in °C
- Secondary pressure loss in mbar
- Primary pressure loss in mbar

Approach

- In Diagram A) the hot water demand at the intersection point of the dispensing volume of 22.5 l/min and primary flow temperature of 70 °C is 1730 l/h.
- In Diagram B) the primary pressure loss for a hot water demand of 1730 l/h is 465 mbar. The pump delivery head is 545 mbar, discounting the pressure loss this gives rise to a residual pump head of 80 mbar (Δp).

- In Diagram C) the primary return temperature for a given dispensing volume of 22.5 l/min and the selected flow temperature of 70 °C is 30 °C.
- In Diagram D) the secondary pressure loss for the given data is 190 mbar

**FLOW AND PRESSURE LOSS DIAGRAMS
COLD WATER HEATING AT 35K (10 ... 45 °C)**

D) Secondary pressure loss

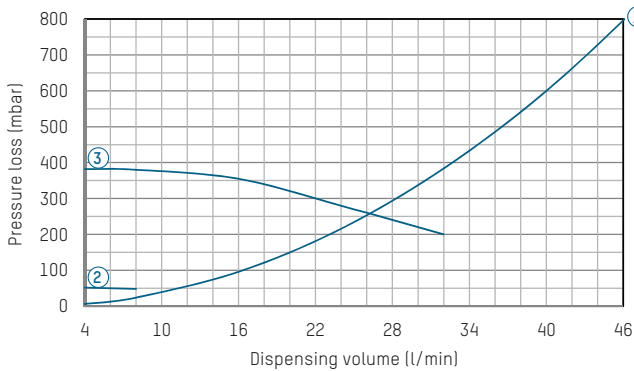

- 1 Pressure loss for cold water and circulation (secondary)
- 2 Circulation pump min
- 3 Circulation pump max
- 4 Primary pressure loss
- 5 Pump characteristic primary side

C) Return temperatures

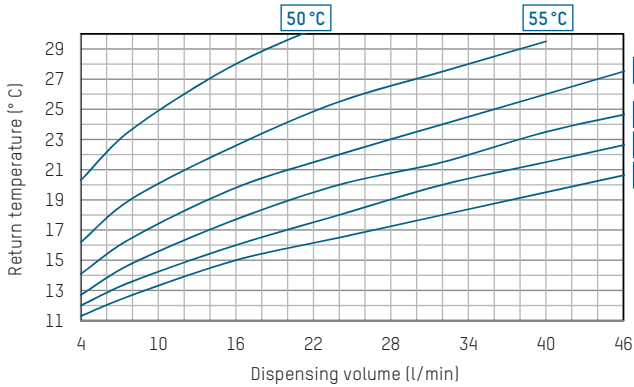

A) Cold water heating at 35K

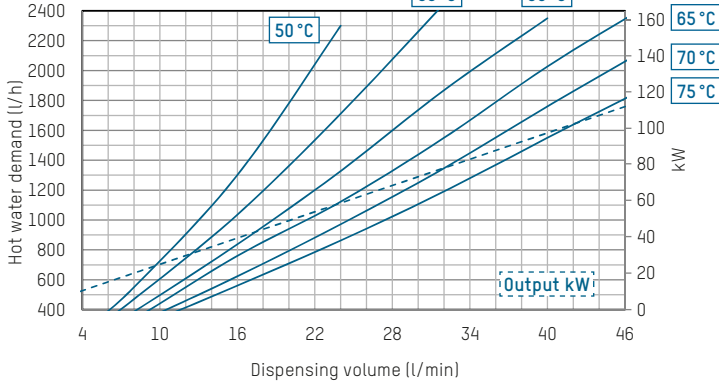

B) Residual head

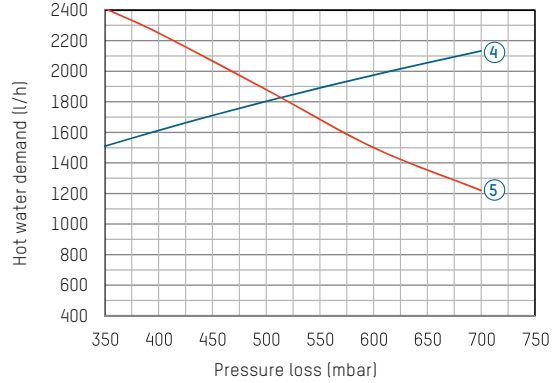

NOTE

REQUIREMENTS FOR FLOW MEDIA

The stations heat interface units use a copper-soldered stainless steel plate heat exchanger as standard. It must be checked prior to use in the framework of system planning whether the issues of corrosion protection and scale formation have been sufficiently taken into account in accordance with DIN 1988200 and current drinking water analyses according to DIN EN 8065.

See datasheet „Plate Heat Exchanger Requirements - Limit Values for Drinking Water Quality“.

ACCESSORIES



COMPONENTS FOR REMOTE ACCESS

Order no.	Rp	Description
296.7027.000		eLink ModBus RTU interface
296.7028.000		eLink RC7020 interface

ACCESSORIES FOR CASCADES

Order no.	Rp	Description
295.0300.000		Basic construction kit
295.0301.000		Extension kit
296.7024.000	1 ¼"	External storage restratification
296.7025.000	2"	External storage restratification
296.0502.000		External circulation

SAMPLE ORDER



CASCADE MODULE WITHOUT SEQUENCE CHANGEOVER

Cascade circuit with integrated circulation and storage stratification

Order no.	2-way cascade	3-way cascade	4-way cascade	5-way cascade
272.2026.000	1	2	3	4
273.2229.000	1	1	1	1
295.0300.000	1	1	1*	1*
295.0301.000	0	1	2*	3*



CASCADE MODULE WITH SEQUENCE CHANGEOVER

Cascade circuit with external circulation and external storage stratification

Order no.	2-way cascade	3-way cascade	4-way cascade	5-way cascade
272.2026.000	2	3	4	5
295.0300.000	1	1	1*	1*
295.0301.000	0	1	2*	3*
296.7024.000	1*	0	0	0
296.7025.000	0	1	1	1
296.0502.000	1	1	1	1
296.7036.000	1	1	1	1

* Attention: Note pressure losses in the cascade pipe sets and diverting valves.

TACOTHERM FRESH MEGA3 X (C/CL)

FRESH HOT WATER STATION WITH HIGH-EFFICIENCY PUMPS



ADVANTAGES

Compact and versatile

- Models: with and without circulation pump, dual-zone return stratification
- Cascading possible

Secure

- Integration in building control system via optionally available eLink ModBus RTU interface
- Integrated safety subassembly and soft-close valves

Simple

- Valves and components are fully preassembled and ready for connection

Efficient

- Simple and fast commissioning

Fresh hot water station for hygienically heating drinking water in accordance with the continuous flow principle with innovative regulation technology

DESCRIPTION

The TacoTherm Fresh Mega3 X (C/CL) fresh water station is used for on-demand preparation of domestic hot water in accordance with the continuous flow principle. It retrieves the heat from the storage tank of an existing or new heating system, which uses solid-fuel boilers, heat pumps, solar systems, etc. as a heat source. The station replaces the storage of hot drinking water and thus provides a high degree of protection against Legionella by avoiding water stagnation.

INSTALLATION POSITION

Vertical wall-mounting in the vicinity of the hot water storage tank or on the tank itself.

OPERATION

Drinking water is heated to the defined dispensing temperature in the TacoTherm Fresh Mega3 X (C/CL) in accordance with the continuous flow principle. The integrated heat exchanger is supplied with as little hot water from the storage tank as is required to maintain a constant dispensing temperature.

The latest pump and regulation technology is used. In recording the temperature difference and flow rate data, the electronic regulator simultaneously records and stores the quantity of heat consumed. In addition to an additional circulation pump that can be installed, the TacoTherm Fresh Mega3 X (C/CL) can also be supplied with a switching valve for dual-zone return stratification. The primary pump, circulation pump as well as load valve are controlled by the integrated regulator in accordance with specifications.

BUILDING CATEGORIES

- Apartment blocks
- Housing estates
- Multiple dwelling units
- Smaller public buildings
- Facilities with partial use – for example barracks, camping sites, etc.

SYSTEM/BASIC DIAGRAM

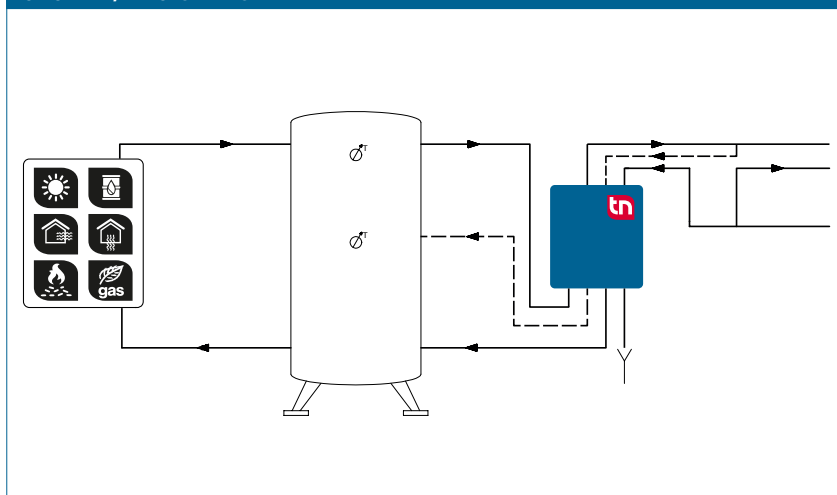

SPECIFICATION TEXT

See www.taconova.com

TECHNICAL DATA

General

- TacoTherm Fresh Mega3 X controller
- Weight (empty): 19.5 – 22 kg
- Overall dimensions (incl. hood):
W 470 mm × H 685 mm × D 193 mm

Material

- Base plate: Galvanized sheet steel
- Rear panel and hood: EPP design insulation
- Pumps:
 - Primary: Cast steel
 - Secondary: PPS (plastic, approved for drinking water)
- Valve housing: Brass
- Pipes: DN 20 stainless steel 1.4404
- Plate heat exchanger:
 - Plates and connector pieces: Stainless steel 1.4401
 - Heat exchanger solder: 99.99 % copper (on request: stainless steel solder)
- Seals: AFM flush seal

Primary side

- Operating temperature $T_{0\ max}$: 95 °C
- Operating pressure $P_{0\ max}$: 10 bar
- Primary pump: Wilo ParaG 25-130/9-87/PWM1

Secondary side

- Operating temperature $T_{0\ max}$: 85 °C
- Operating pressure $P_{0\ max}$: 10 bar
- Safety valve (intrinsic safety): 10 bar
- Circulation pump: TacoFlow2 Pure C 15-40/130 C6

Electrical connection data

- Mains voltage: 230 VAC ± 10 %
- Mains frequency: 50...60 Hz
- Power consumption: max. 250 W
- 3.5 AT fuse
- eBus interface
- Protection type: IP 40

Flow media

- Heating water (VDI 2035; SWKI BT 102-01; ÖNORM H 5195-1)
- Cold water

APPROVALS / CERTIFICATES

- Components in contact with potable water comply with UBA Evaluation Criteria 26/03/2018 and Directive (EU) 2015/1535
- SVGW: 1808-6783

TYPE OVERVIEW

TacoTherm Fresh Mega3 X | Fresh hot water station

Order no.	Rp ¾"	Rp 1"	Version	Version
272.5076.000	⑤ ⑥	① ②	X	Without circulating pump, without dual-zone return stratification
273.5276.000	⑤ ⑥	① ③ ④	XC	With circulating pump, without dual-zone return stratification
273.5279.000	⑤ ⑥	①-④	XCL	With circulating pump and dual-zone return stratification

DIMENSIONAL DRAWING

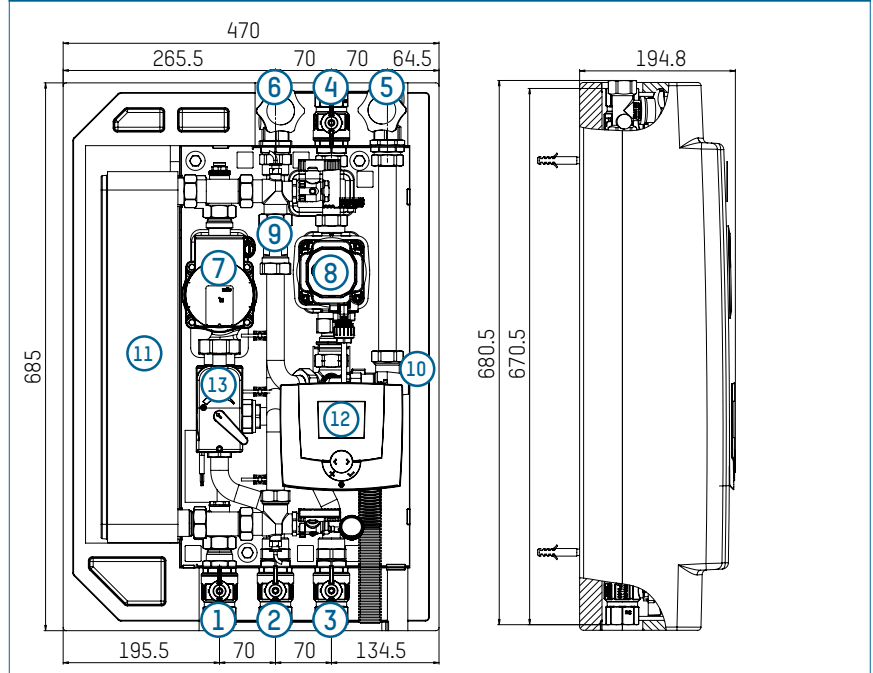

PRODUCT DIAGRAM

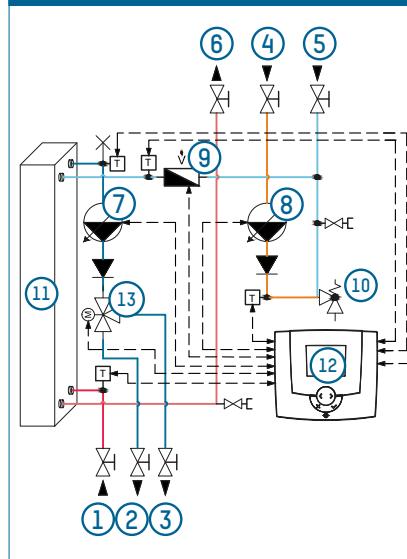

- 1 Primary hot water flow
- 2 Primary hot water return 1 (integration of storage tank in center in CL models)
- 3 Primary hot water return 2 (integration of storage tank below)
- 4 Circulation (C/CL version)
- 5 Cold water connection (¾")
- 6 Hot water connection
- 7 Primary pump
- 8 Circulation pump (C/CL version)
- 9 Flow rate sensor
- 10 Safety valve
- 11 Heat exchanger
- 12 Regulator
- 13 Switching valve (CL version)

**FLOW AND PRESSURE LOSS DIAGRAMS
COLD WATER HEATING AT 50K (10 ... 60 °C)**

D) Secondary pressure loss

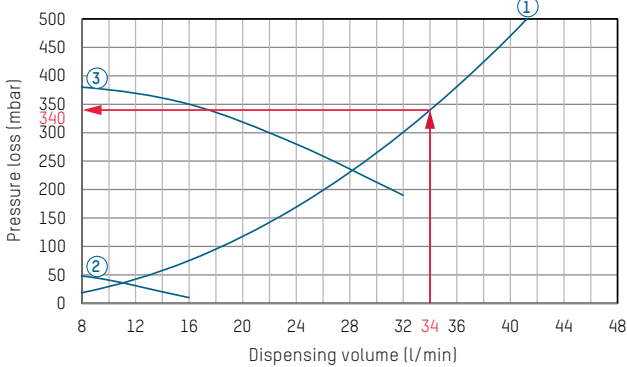

- 1 Pressure loss for cold water and circulation (secondary)
- 2 Circulation pump min
- 3 Circulation pump max
- 4 Primary pressure loss
- 5 Pump characteristic primary side

C) Return temperatures

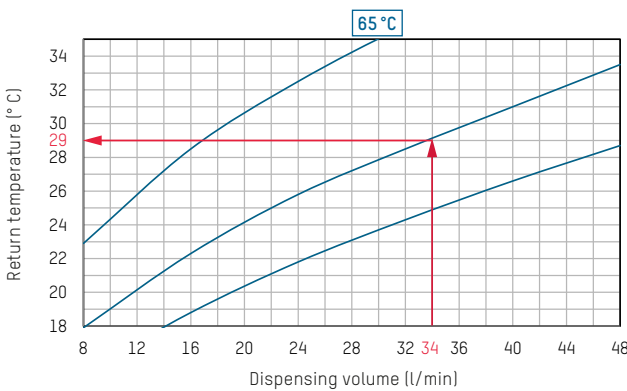

A) Cold water heating at 50K

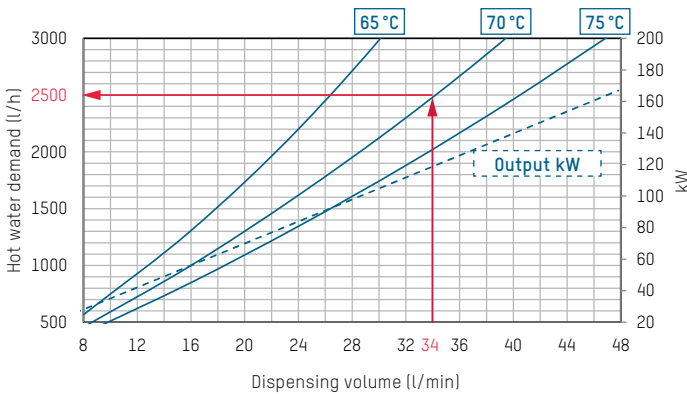

B) Residual head

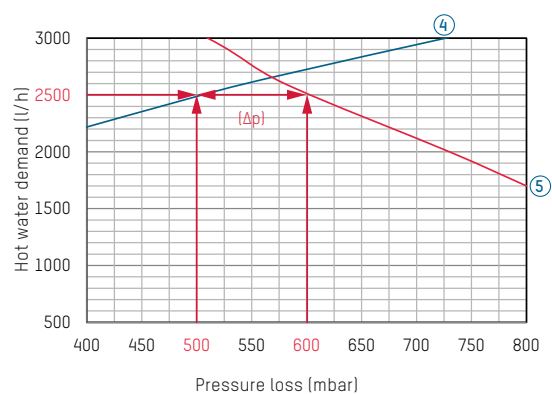

EXAMPLE FOR INTERPRETING THE FLOW RATE AND PRESSURE LOSS DIAGRAMS

Given

- Hot water dispensing volume: 34 l/min
- Primary heating flow temperature: 70 °C

Sought

- Hot water demand (l/h)
- Primary heating return temperature in °C
- Secondary pressure loss in mbar
- Primary pressure loss in mbar

Approach

- In Diagram A) the hot water demand at the intersection point of the dispensing volume of 34 l/min and primary flow temperature of 70 °C is 2500 l/h.
- In Diagram B) the primary pressure loss for a hot water demand of 2500 l/h is 500 mbar. The pump delivery head is 600 mbar, discounting the pressure loss this gives rise to a residual pump head of 100 mbar (Δp).

- In Diagram C) the primary return temperature for a given dispensing volume of 34 l/min and the selected flow temperature of 70 °C is 29 °C.
- In Diagram D) the secondary pressure loss for the given data is 340 mbar.

FLOW AND PRESSURE LOSS DIAGRAMS
COLD WATER HEATING AT 35K (10 ... 45 °C)

D) Secondary pressure loss

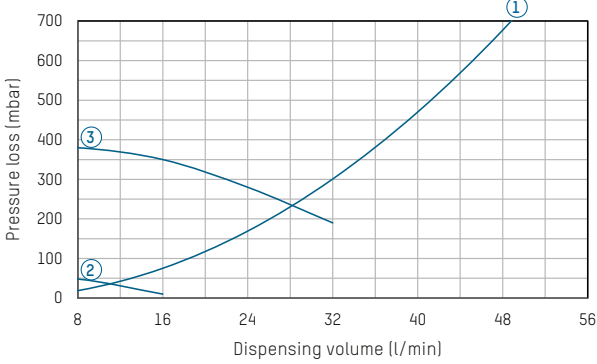

- 1 Pressure loss for cold water and circulation (secondary)
- 2 Circulation pump min
- 3 Circulation pump max
- 4 Primary pressure loss
- 5 Pump characteristic primary side

C) Return temperatures

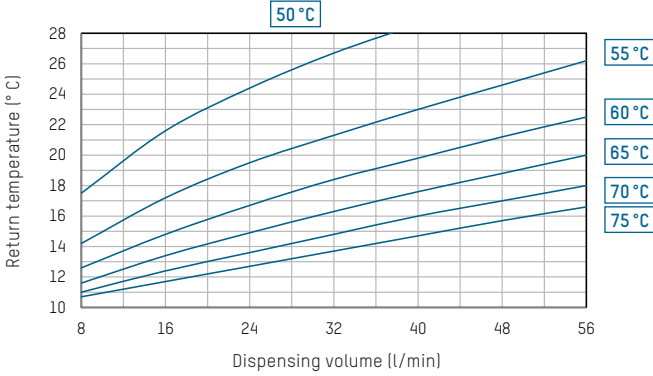

A) Cold water heating at 35K

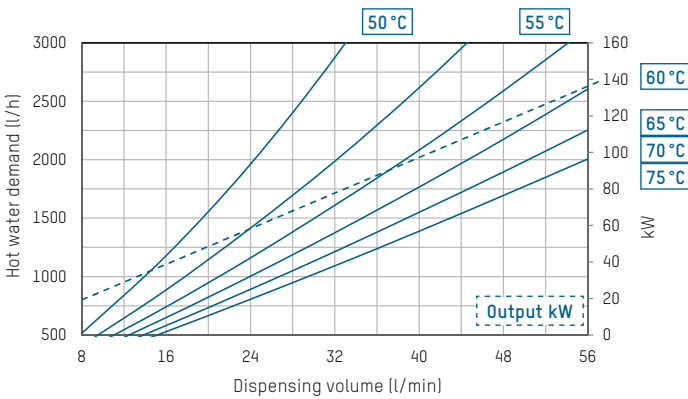

B) Residual head | Primary pressure loss

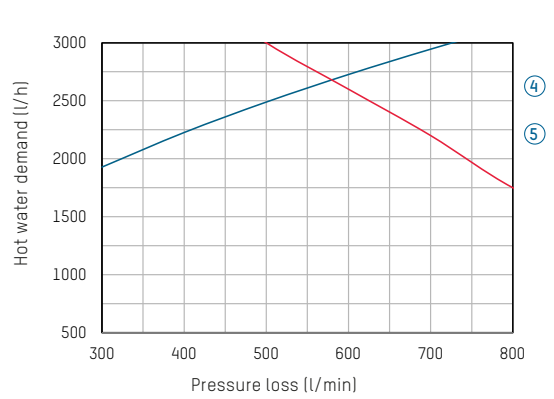

NOTE

REQUIREMENTS FOR FLOW MEDIA

The stations heat interface units use a copper-soldered stainless steel plate heat exchanger as standard. It must be checked prior to use in the framework of system planning whether the issues of corrosion protection and scale formation have been sufficiently taken into account in accordance with DIN 1988200 and current drinking water analyses according to DIN EN 8065.

See datasheet „Plate Heat Exchanger Requirements - Limit Values for Drinking Water Quality“.

ACCESSORIES



COMPONENTS FOR REMOTE ACCESS

Order no.	Rp	Description
296.7027.000		eLink ModBus RTU interface
296.7028.000		eLink RC7020 interface

ACCESSORIES FOR CASCADES

Order no.	Rp	Description
295.0300.000		Basic construction kit
295.0301.000		Extension kit
296.7024.000	1 ¼"	External storage restratification
296.7025.000	2"	External storage restratification
296.0502.000		External circulation

SAMPLE ORDER



CASCADE MODULE WITHOUT SEQUENCE CHANGEOVER

Cascade circuit with integrated circulation and storage stratification

Order no.	2-way cascade	3-way cascade	4-way cascade	5-way cascade
272.5076.000	1	2	3	4
273.5279.000	1	1	1	1
295.0300.000	1	1	1*	1*
295.0301.000	0	1	2*	3*



CASCADE MODULE WITH SEQUENCE CHANGEOVER

Cascade circuit with external circulation and external storage stratification

Order no.	2-way cascade	3-way cascade	4-way cascade	5-way cascade
272.5076.000	2	3	4	5
295.0300.000	1	1	1*	1*
295.0301.000	0	1	2*	3*
296.7024.000	1*	0	0	0
296.7025.000	0	1	1	1
296.0502.000	1	1	1	1
296.7036.000	1	1	1	1

* Attention: Note pressure losses in the cascade pipe sets and diverting valves.

TACOTHERM FRESH PETA2 (C/CL)

FRESH HOT WATER STATION WITH HIGH-EFFICIENCY PUMPS



Fresh hot water station for hygienically heating drinking water in accordance with the continuous flow principle with and without dual-zone return stratification of the storage tank.

DESCRIPTION

The TacoTherm Fresh Peta2 (C/CL) fresh water station is used for on-demand preparation of domestic hot water in accordance with the continuous flow principle. It retrieves the heat from the storage tank of an existing or new heating system, which uses solid-fuel boilers, heat pumps, solar systems, etc. as a heat source. The station replaces the storage of hot drinking water and thus provides a high degree of protection against Legionella by avoiding water stagnation.

INSTALLATION POSITION

Vertical wall-mounting in the vicinity of the hot water storage tank or on the tank itself.

OPERATION

Drinking water is heated to the defined dispensing temperature in the TacoTherm Fresh Peta2 (C/CL) in accordance with the continuous flow principle. The integrated heat exchanger is supplied with as little hot water from the storage tank as is required to maintain a constant dispensing temperature.

ADVANTAGES

Compact and versatile

- Models: with and without circulation pump, dual-zone return stratification
- Cascading possible

Secure

- Integration in building control system via optionally available eLink ModBus RTU interface
- Integrated safety subassembly and soft-close valves

Simple

- Valves and components are fully preassembled and ready for connection

Efficient

- High transmission performance and low pressure loss thanks to microplate plate heat exchanger

A low return temperature of the heating water to the storage tank can be expected owing to the special design of the heat exchanger. In recording the temperature difference and flow rate data, the electronic regulator simultaneously records and stores the quantity of heat consumed. In addition to an additional circulation pump that can be installed, the TacoTherm Fresh Peta2 (C/CL) can also be supplied with a switching valve for dual-zone return stratification.

The primary pump, circulation pump as well as load valve are controlled by the integrated regulator in accordance with specifications.

SYSTEM/BASIC DIAGRAM

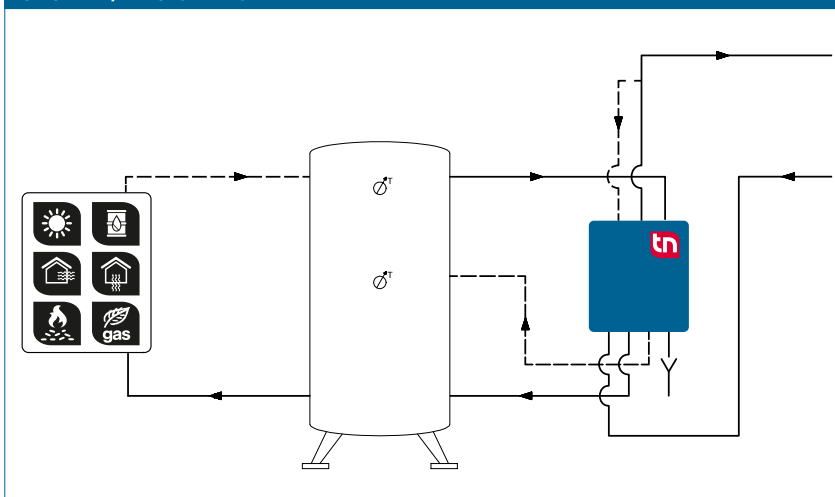

BUILDING CATEGORIES

- Apartment blocks
- Housing estates
- Multiple dwelling units
- Residential care facilities and hospitals
- Administration and service buildings
- Hotels and restaurants, industrial kitchens
- School buildings and sports facilities
- Commercial and industrial buildings, industrial facilities
- Facilities with partial use – for example barracks, camping sites, etc.

SPECIFICATION TEXT

See www.taconova.com

TECHNICAL DATA

General

- TacoTherm Fresh Peta2 controller with display
- Weight (empty): 39.5 – 43 kg
- Overall dimensions (incl. hood): W 530 mm × H 854 mm × D 194 mm

Material

- Base plate: Galvanized sheet steel
- Hood: stylish EPP insulation
- Pumps:
 - Primary: Cast iron
 - Secondary: PPS (plastic, approved for drinking water)
- Valve housing: Brass
- Pipes:
 - Primary/secondary DN 32, stainless steel 1.4404
 - Circulation DN 25, stainless steel 1.4404
- Microplate plate heat exchanger:
 - Plates and connector pieces: Stainless steel 1.4401
 - Heat exchanger solder: 99.99 % copper (on request: stainless steel solder)
- Seals: AFM flush seal

Primary side

- Operating temperature $T_{0\max}$: 95 °C
- Operating pressure $P_{0\max}$: 10 bar
- Primary pump: Wilo-Para G 25-130/PWM1

Secondary side

- Operating temperature $T_{0\max}$: 85 °C
- Operating pressure $P_{0\max}$: 10 bar
- Safety valve (intrinsic safety): 10 bar
- Circulation pump: TacoFlow2 Pure 15-40/130 C6

Electrical connection data

- Mains voltage: 230 VAC ± 10 %
- Mains frequency: 50...60 Hz
- Power consumption: max. 250 W
- 3.5 AT fuse
- eBus interface
- Protection type: IP 40

Flow media

- Heating water (VDI 2035; SWKI BT 102-01; ÖNORM H 5195-1)
- Cold water

APPROVALS / CERTIFICATES

- Components in contact with potable water comply with UBA Evaluation Criteria 26/03/2018 and Directive (EU) 2015/1535
- SVGW: 1808-6782

TYPE OVERVIEW

TacoTherm Fresh Peta2 | Fresh hot water station

Order no.	Rp 1"	Rp 1¼"	Version	Version
272.5066.000		① ② ⑤ ⑥		Without circulating pump, without dual-zone return stratification
273.5266.000	④	① ② ⑤ ⑥	C	With circulating pump, without dual-zone return stratification
273.5269.000	④	① ② ③ ⑤ ⑥	CL	With circulating pump and dual-zone return stratification

DIMENSIONAL DRAWING

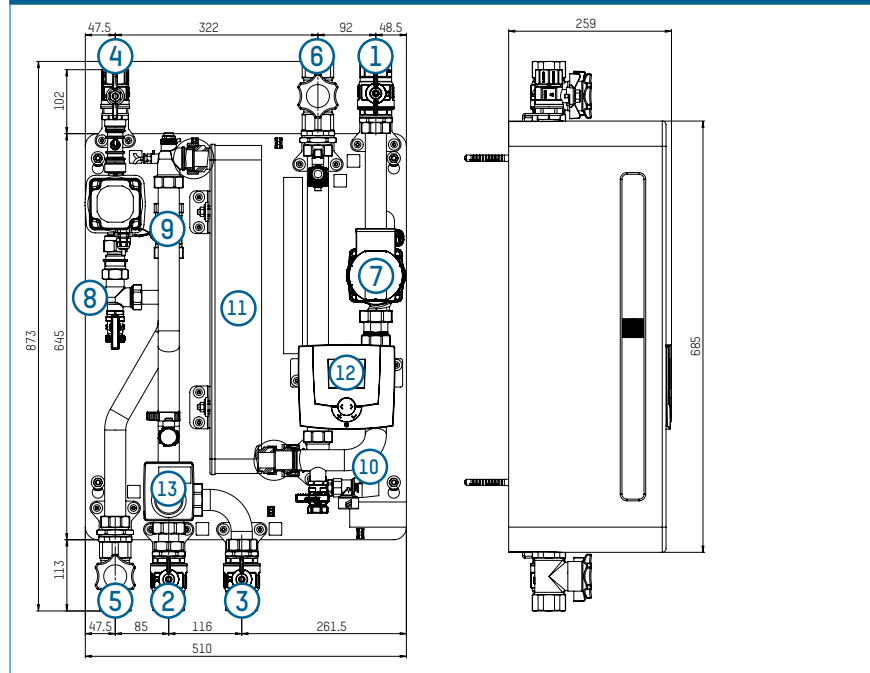

PRODUCT DIAGRAM

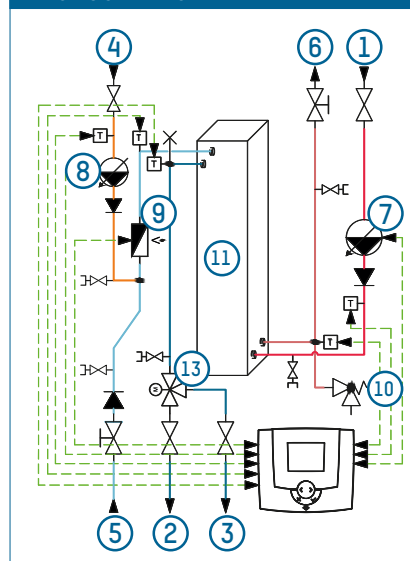

- 1 Primary hot water flow
- 2 Primary hot water return 1 (integration of storage tank below)
- 3 Primary hot water return 2 (integration of storage tank in center in CL models)
- 4 Circulation (C/CL version) (1")
- 5 Cold water connection
- 6 Hot water connection
- 7 Primary pump
- 8 Circulation pump (C/CL version)
- 9 Flow rate sensor
- 10 Safety valve
- 11 Heat exchanger
- 12 Regulator
- 13 Switching valve (CL version)

**FLOW AND PRESSURE LOSS DIAGRAMS
COLD WATER HEATING AT 50K (10 ... 60 °C)**

D) Secondary pressure loss

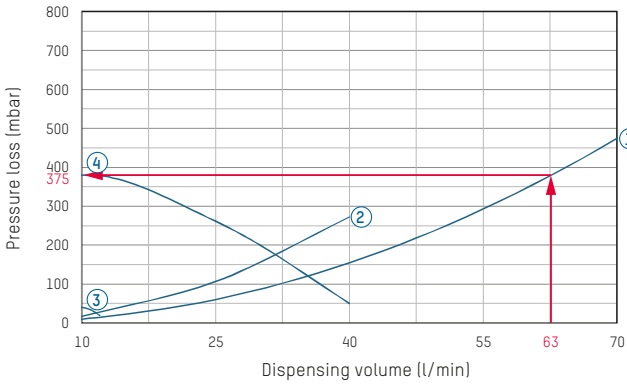

- 1 Secondary pressure loss
- 2 Secondary pressure loss in circulation
- 3 Circulation pump min
- 4 Circulation pump max
- 5 Primary pressure loss
- 6 Pump characteristic primary side

C) Return temperatures

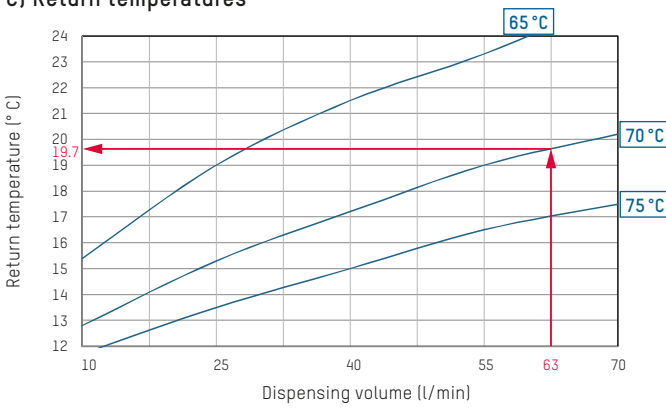

A) Cold water heating at 50K

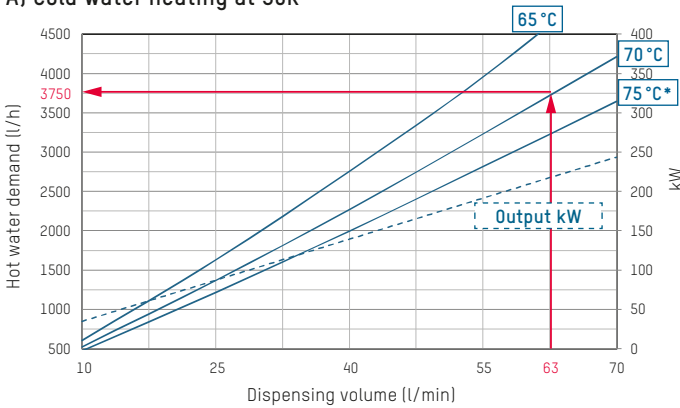

B) Residual head | Primary pressure loss

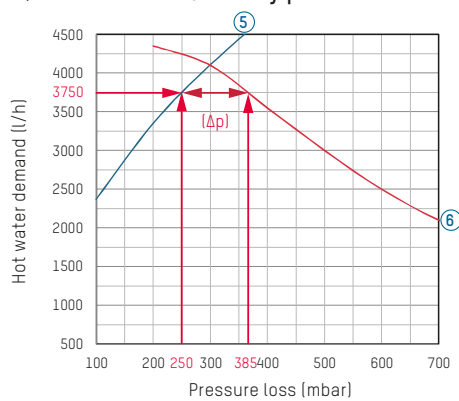

EXAMPLE FOR INTERPRETING THE FLOW RATE AND PRESSURE LOSS DIAGRAMS

Given

- Hot water dispensing volume: 63 l/min
- Primary heating flow temperature: 70 °C

Sought

- Hot water demand (l/h)
- Primary heating return temperature in °C
- Secondary pressure loss in mbar
- Primary pressure loss in mbar

Approach

- In Diagram A) the hot water demand at the intersection point of the dispensing volume of 63 l/min and primary flow temperature of 70 °C is 3750 l/h.
- In Diagram B) the primary pressure loss for a hot water demand of 3750 l/h is 250 mbar. The pump delivery head is 370 mbar, discounting the pressure loss this gives rise to a residual pump head of 120 mbar (Δp).

- In Diagram C) the primary return temperature for a given dispensing volume of 63 l/min and the selected flow temperature of 70 °C is 19.7 °C.
- In Diagram D) the secondary pressure loss for the given data is 385 mbar

FLOW AND PRESSURE LOSS DIAGRAMS
COLD WATER HEATING AT 35K (10 ... 45 °C)

D) Secondary pressure loss

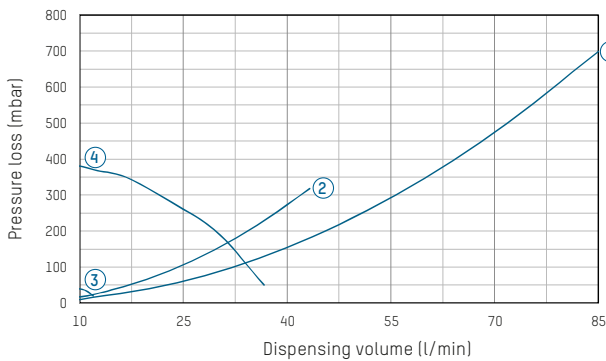

- 1 Secondary pressure loss
- 2 Secondary pressure loss in circulation
- 3 Circulation pump min
- 4 Circulation pump max
- 5 Primary pressure loss
- 6 Pump characteristic primary side

C) Return temperatures

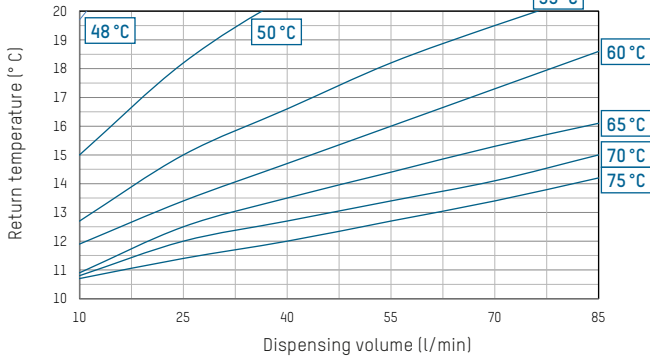

A) Cold water heating at 35K

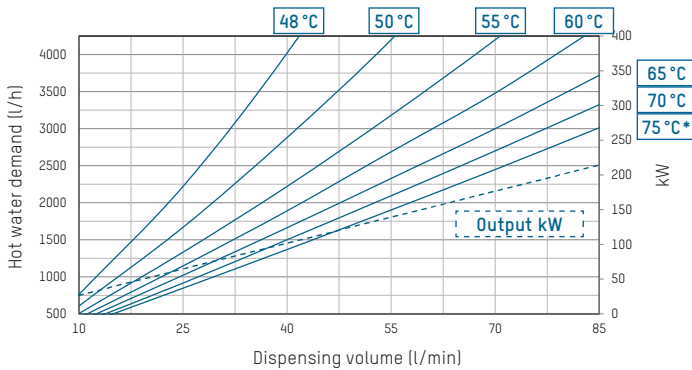

B) Residual head | Primary pressure loss

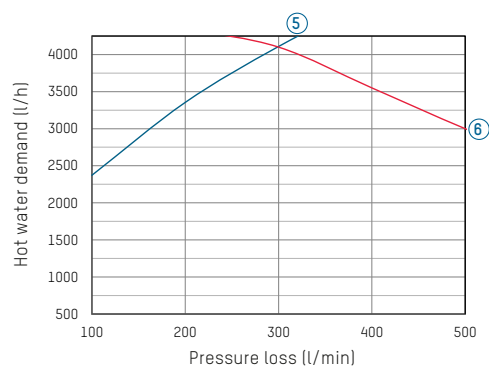

NOTE

REQUIREMENTS FOR FLOW MEDIA

The stations heat interface units use a copper-soldered stainless steel plate heat exchanger as standard. It must be checked prior to use in the framework of system planning whether the issues of corrosion protection and scale formation have been sufficiently taken into account in accordance with DIN 1988200 and current drinking water analyses according to DIN EN 8065.

See datasheet „Plate Heat Exchanger Requirements - Limit Values for Drinking Water Quality“.

ACCESSORIES



COMPONENTS FOR REMOTE ACCESS

Order no.	Rp	Description
296.7027.000		eLink ModBus RTU interface
296.7028.000		eLink RC7020 interface

ACCESSORIES FOR CASCADES

Order no.	Rp	Description
295.0100.000		Basic construction kit
295.0101.000		Extension kit
296.7026.000		Second zone valve for basic construction kit (sequence switching operation)
296.7024.000	1 1/4"	External storage restratification
296.7025.000	2"	External storage restratification
296.0502.000		External circulation

SAMPLE ORDER



CASCADE MODULE WITHOUT SEQUENCE CHANGEOVER

Cascade circuit with integrated circulation and storage stratification

Order no.	2-way cascade	3-way cascade	4-way cascade	5-way cascade
272.5066.000	1	2	3	4
273.5269.000	1	1	1	1
295.0100.000	1	1	1*	1*
295.0101.000	0	1	2*	3*



CASCADE MODULE WITH SEQUENCE CHANGEOVER

Cascade circuit with external circulation and external storage stratification

Order no.	2-way cascade	3-way cascade	4-way cascade	5-way cascade
272.5066.000	2	3	4	5
295.0100.000	1	1	1*	1*
295.0101.000	0	1	2*	3*
296.7026.000	1	1	1	1
296.7024.000	1*	0	0	0
296.7025.000	0	1	1	1
296.0502.000	1	1	1	1
296.7026.000	1	1	1	1

* Attention: Note pressure losses in the cascade pipe sets and diverting valves.

TACOTHERM FRESH PETA2 X (C/CL)

FRESH HOT WATER STATION WITH HIGH-EFFICIENCY PUMPS



Fresh hot water station for hygienically heating drinking water in accordance with the continuous flow principle with and without dual-zone return stratification of the storage tank.

DESCRIPTION

The TacoTherm Fresh Peta2 X (C/CL) fresh water station is used for on-demand preparation of domestic hot water in accordance with the continuous flow principle. It retrieves the heat from the storage tank of an existing or new heating system, which uses solid-fuel boilers, heat pumps, solar systems, etc. as a heat source. The station replaces the storage of hot drinking water and thus provides a high degree of protection against Legionella by avoiding water stagnation.

INSTALLATION POSITION

Vertical wall-mounting in the vicinity of the hot water storage tank or on the tank itself.

OPERATION

Drinking water is heated to the defined dispensing temperature in the TacoTherm Fresh Peta2 X (C/CL) in accordance with the continuous flow principle. The integrated heat exchanger is supplied with as little hot water from the storage tank as is required to maintain a constant dispensing temperature.

ADVANTAGES

Compact and versatile

- Models: with and without circulation pump, dual-zone return stratification
- Cascading possible

Secure

- Integration in building control system via optionally available eLink ModBus RTU interface
- Integrated safety subassembly and soft-close valves

Simple

- Valves and components are fully preassembled and ready for connection

Efficient

- High transmission performance and low pressure loss thanks to microplate plate heat exchanger

A low return temperature of the heating water to the storage tank can be expected owing to the special design of the heat exchanger. In recording the temperature difference and flow rate data, the electronic regulator simultaneously records and stores the quantity of heat consumed. In addition to an additional circulation pump that can be installed, the TacoTherm Fresh Peta2 X (C/CL) can also be supplied with a switching valve for dual-zone return stratification.

The primary pump, circulation pump as well as load valve are controlled by the integrated regulator in accordance with specifications.

SYSTEM/BASIC DIAGRAM

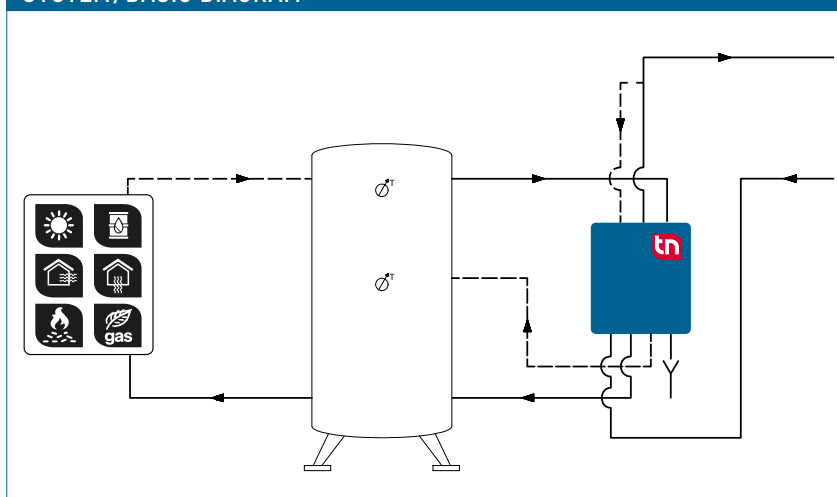

BUILDING CATEGORIES

- Apartment blocks
- Housing estates
- Multiple dwelling units
- Residential care facilities and hospitals
- Administration and service buildings
- Hotels and restaurants, industrial kitchens
- School buildings and sports facilities
- Commercial and industrial buildings, industrial facilities
- Facilities with partial use – for example barracks, camping sites, etc.

SPECIFICATION TEXT

See www.taconova.com

TECHNICAL DATA

General

- TacoTherm Fresh Peta2 controller with display
- Weight (empty): 42 – 46 kg
- Overall dimensions (incl. hood): W 530 mm × H 854 mm × D 194 mm

Material

- Base plate: Galvanized sheet steel
- Hood: stylish EPP insulation
- Pumps:
 - Primary: Cast iron
 - Secondary: PPS (plastic, approved for drinking water)
- Valve housing: Brass
- Pipes:
 - Primary/secondary DN 32, stainless steel 1.4404
 - Circulation DN 25, stainless steel 1.4404
- Microplate plate heat exchanger:
 - Plates and connector pieces: Stainless steel 1.4401
 - Heat exchanger solder: 99.99 % copper (on request: stainless steel solder)
- Seals: AFM flush seal

Primary side

- Operating temperature $T_{0\ max}$: 95 °C
- Operating pressure $P_{0\ max}$: 10 bar
- Primary pump: TacoFlow3 MAX 25-100/180 C6

Secondary side

- Operating temperature $T_{0\ max}$: 85 °C
- Operating pressure $P_{0\ max}$: 10 bar
- Safety valve (intrinsic safety): 10 bar
- Circulation pump: Wilo Yonos PARA-Z 15/7.0

Electrical connection data

- Mains voltage: 230 VAC ± 10 %
- Mains frequency: 50...60 Hz
- Power consumption: max. 250 W
- 3.5 AT fuse
- eBus interface
- Protection type: IP 40

Flow media

- Heating water (VDI 2035; SWKI BT 102-01; ÖNORM H 5195-1)
- Cold water

APPROVALS / CERTIFICATES

- Components in contact with potable water comply with UBA Evaluation Criteria 26/03/2018 and Directive (EU) 2015/1535
- SVGW: 1808-6782

TYPE OVERVIEW

TacoTherm Fresh Peta2 X | Fresh hot water station

Order no.	Rp 1"	Rp 1¼"	Version	Version
272.2056.000		① ② ⑤ ⑥	X	Without circulating pump, without dual-zone return stratification
273.2556.000	④	① ② ⑤ ⑥	X C	With circulating pump, without dual-zone return stratification
273.2259.000	④	① ② ③ ⑤ ⑥	X CL	With circulating pump and dual-zone return stratification

DIMENSIONAL DRAWING

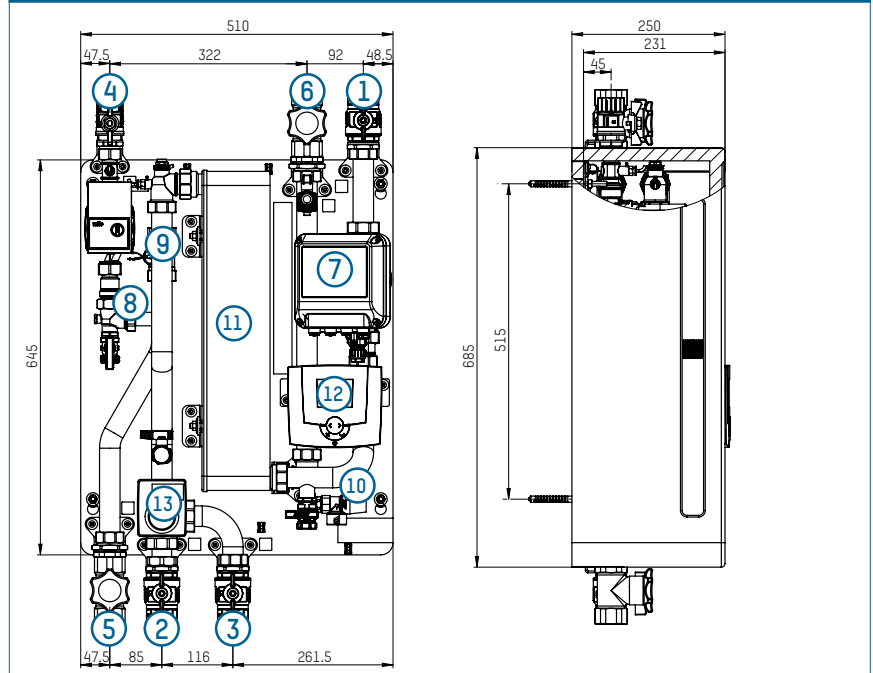

PRODUCT DIAGRAM

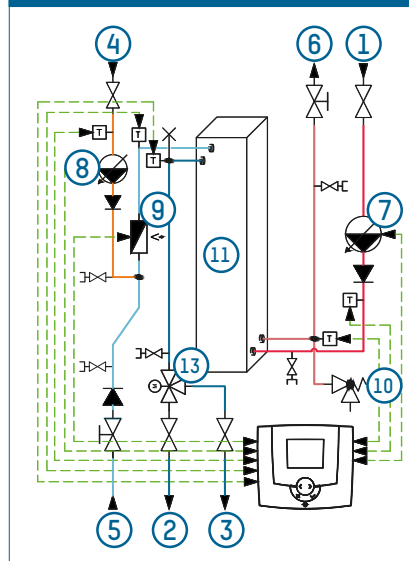

- 1 Primary hot water flow
- 2 Primary hot water return 1 (integration of storage tank below)
- 3 Primary hot water return 2 (integration of storage tank in center in CL models)
- 4 Circulation (C/CL version) (1*)
- 5 Cold water connection
- 6 Hot water connection
- 7 Primary pump
- 8 Circulation pump (C/CL version)
- 9 Flow rate sensor
- 10 Safety valve
- 11 Heat exchanger
- 12 Regulator
- 13 Switching valve (CL version)

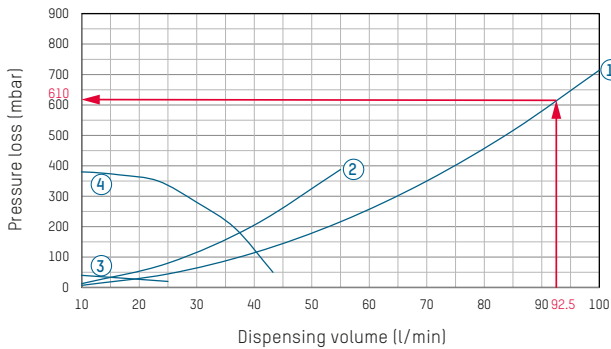
**FLOW AND PRESSURE LOSS DIAGRAMS
COLD WATER HEATING AT 50K (10 ... 60 °C)**
D) Secondary pressure loss

- 1 Secondary pressure loss
- 2 Secondary pressure loss in circulation
- 3 Circulation pump min
- 4 Circulation pump max
- 5 Primary pressure loss
- 6 Pump characteristic primary side

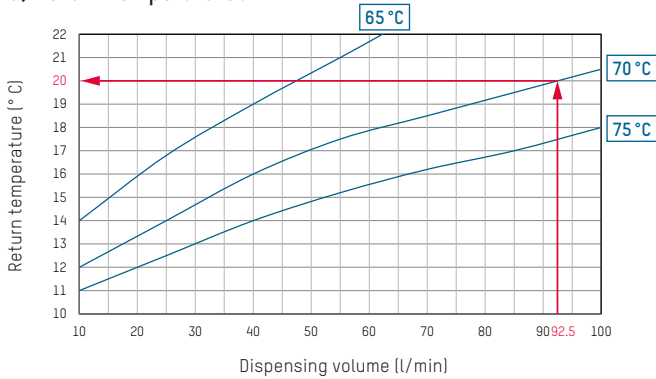
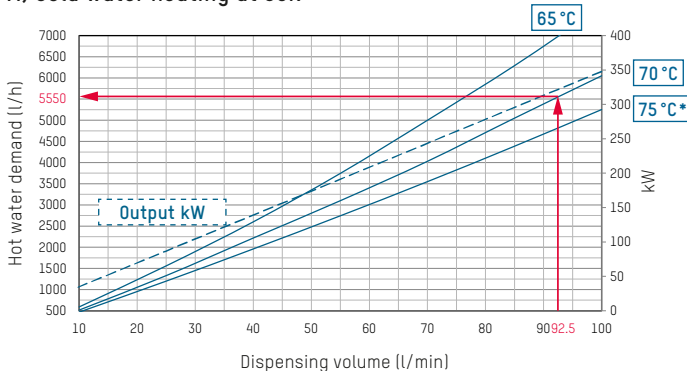
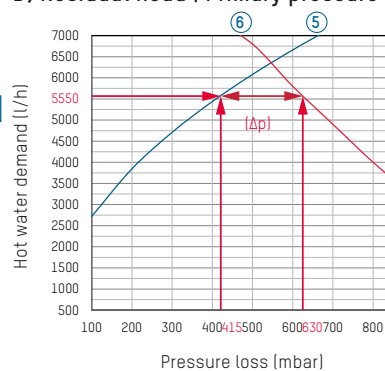
C) Return temperatures

A) Cold water heating at 50K

B) Residual head | Primary pressure loss

EXAMPLE FOR INTERPRETING THE FLOW RATE AND PRESSURE LOSS DIAGRAMS
Given

- Hot water dispensing volume: 92.5 l/min
- Primary heating flow temperature: 70 °C

Sought

- Hot water demand (l/h)
- Primary heating return temperature in °C
- Secondary pressure loss in mbar
- Primary pressure loss in mbar

Approach

- In Diagram A) the hot water demand at the intersection point of the dispensing volume of 92.5 l/min and primary flow temperature of 70 °C is 5550 l/h.
- In Diagram B) the primary pressure loss for a hot water demand of 5550 l/h is 415 mbar. The pump delivery head is 630 mbar, discounting the pressure loss this gives rise to a residual pump head of 215 mbar (Δp).

- In Diagram C) the primary return temperature for a given dispensing volume of 92.5 l/min and the selected flow temperature of 70 °C is 20 °C.
- In Diagram D) the secondary pressure loss for the given data is 610 mbar

FLOW AND PRESSURE LOSS DIAGRAMS
COLD WATER HEATING AT 35K (10 ... 45 °C)

D) Secondary pressure loss

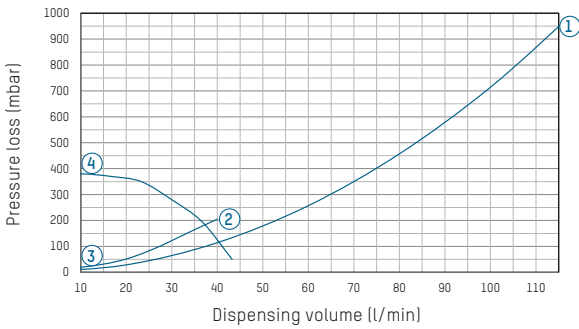

- 1 Secondary pressure loss
- 2 Secondary pressure loss in circulation
- 3 Circulation pump min
- 4 Circulation pump max
- 5 Primary pressure loss
- 6 Pump characteristic primary side

C) Return temperatures

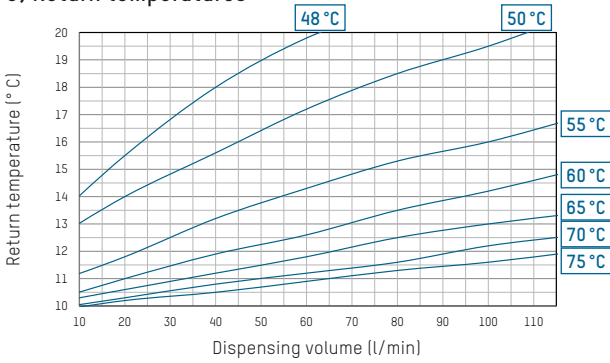

A) Cold water heating at 35K

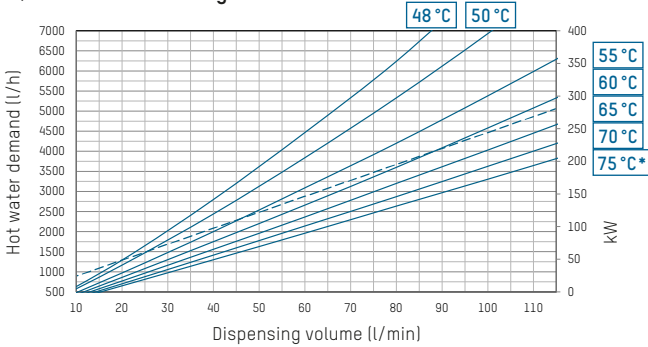

B) Residual head | Primary pressure loss

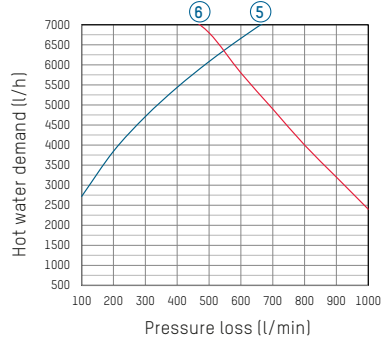

NOTE

REQUIREMENTS FOR FLOW MEDIA

The stations heat interface units use a copper-soldered stainless steel plate heat exchanger as standard. It must be checked prior to use in the framework of system planning whether the issues of corrosion protection and scale formation have been sufficiently taken into account in accordance with DIN 1988200 and current drinking water analyses according to DIN EN 8065. See datasheet „Plate Heat Exchanger Requirements - Limit Values for Drinking Water Quality“.

ACCESSORIES



COMPONENTS FOR REMOTE ACCESS

Order no.	Rp	Description
296.7027.000		eLink ModBus RTU interface
296.7028.000		eLink RC7020 interface

ACCESSORIES FOR CASCADES

Order no.	Rp	Description
295.0100.000		Basic construction kit
295.0101.000		Extension kit
296.7026.000		Second zone valve for basic construction kit (sequence switching operation)
296.7025.000	2"	External storage restratification
296.0502.000		External circulation

SAMPLE ORDER



CASCADE MODULE WITHOUT SEQUENCE CHANGEOVER

Cascade circuit with integrated circulation and storage stratification

Order no.	2-way cascade	3-way cascade	4-way cascade	5-way cascade
272.2056.000	1	2	3	4
273.2259.000	1	1	1	1
295.0100.000	1	1	1*	1*
295.0101.000	0	1	2*	3*



CASCADE MODULE WITH SEQUENCE CHANGEOVER

Cascade circuit with external circulation and external storage stratification

Order no.	2-way cascade	3-way cascade	4-way cascade	5-way cascade
272.2056.000	2	3	4	5
295.0100.000	1	1	1*	1*
295.0101.000	0	1	2*	3*
296.7026.000	1	1	1	1
296.7025.000	1	1	1	1
296.0502.000	1	1	1	1
296.7026.000	1	1	1	1

* Attention: Note pressure losses in the cascade pipe sets and diverting valves.

PLATE HEAT EXCHANGER – LIMIT VALUES FOR DRINKING WATER QUALITY

Corrosion resistance of soldered plate heat exchangers to water-borne substances – the soldered plate heat exchanger consists of stamped stainless steel plates 1.4401/1.4404 or SA240 316/SA240 316L

The plate heat exchangers in Tacovina fresh hot water stations are produced as standard as copper soldered stainless steel plate heat exchangers. Before these heat exchangers can be used, building services engineers and installation companies have to check in the framework of system planning whether the issues of corrosion protection and scale formation have been sufficiently taken into account in accordance with DIN 1988-200

and DIN EN 806-5 as well as current drinking water analyses.

This includes the following points:

- Selection of materials
- Consideration of corrosion-related changes to the drinking water quality
- Performance of installation
- Consideration of anticipated operating conditions

Signs of corrosion may occur in copper materials with high electrical conductivity of the drinking water of

more than 500 $\mu\text{S}/\text{cm}$, which could cause damage to the copper solder in the heat exchanger. For electrical conductivities of $> 500 \mu\text{S}/\text{cm}$, we therefore recommend the use of our nickel- or stainless-steel-soldered plate heat exchangers. The following values for water-borne substances and characteristic values should be observed (1.4401/1.4404 / SA240 316/SA240 316L):

Water-borne substances and characteristic values	Unit	Plate heat exchanger		
		Copper-soldered	Nickel-soldered	Stainless-steel-soldered
pH value		7 – 9 (considering the SI index)	6 – 10	6 – 10
Saturation index SI (delta pH value)		-0,2 < 0 < +0,2	Not specified	
Total hardness	°dH	6 – 15	6 – 15	6 – 15
Conductivity	$\mu\text{S}/\text{cm}$	10 ... 500	10-1000	Not specified
Substances that can be filtered out	mg/l	< 30	< 30	< 30
Chloride*	mg/l	No chloride permitted above 100° C		
Free chlorine free	mg/l	< 0,5	< 0,5	< 0,5
Hydrogen sulfide (H ₂ S)	mg/l	< 0,05	Not specified	
Ammonia (NH ₃ /NH ₄ ⁺)	mg/l	< 2	< 2	Not specified
Sulfate	mg/l	< 100	< 300	< 400
Hydrogen carbonate	mg/l	< 300	Not specified	
Hydrogen carbonate / sulfate	mg/l	> 1,0	Not specified	
Sulfide	mg/l	< 1	< 5	< 7
Nitrate	mg/l	< 100	Not specified	
Nitrite	mg/l	< 0,1	Not specified	
Iron (dissolved)	mg/l	< 0,2	Not specified	
Manganese	mg/l	< 0,1	Not specified	
Free (aggressive) carbonic acid	mg/l	< 20	Not specified	

* At 20 °C max. 600 mg/l | At 25 °C max. 500 mg/l | At 50 °C max. 200 mg/l | At 75 °C max. 75 mg/l | ≥ 100 °C max. 0 mg/l
The specified values are guide values, which may deviate under certain operating conditions

MAXIMUM ENERGY USE BY THE COLLECTOR

Storage loading stations transfer the solar heat from the collector to the right storage tank zone.

OPTIMAL USE OF THE SOLAR COLLECTOR

The TacoSol Load storage loading stations increase the usage heat from solar systems by loading different zones of the storage tank depending on the available temperature from the solar circuit. In order to achieve optimum discharge of the solar collector, the temperature difference of the flow and return of the solar thermal energy system is significant.

Low return temperatures ensure a high level of thermal transfer in the storage tank and the optimum discharge of the collector.

SECURE AND EFFICIENT USE OF SOLAR ENERGY AND REGENERATIVE ENERGIES

When using heat generators that are powered by renewable energies or that operated according to the principle of power-heat coupling, the heat produced is stored in a storage tank. Examples of this are solar heating systems, heat pumps, block heating stations or wood pellet and wood burning boilers. The storage tank means that long burner/aggregate running times can be achieved and free solar energy can be used efficiently.

STRATIFIED STORAGE UNIT LOADING WITH EXTERNAL LOADING STATIONS

The loading of storage tanks has a major influence over how efficiently the thermal energy generated by a solar energy or heating system can be used. It is important to avoid disrupting currents in the storage tank in order to support stratification. Eddies that impact on stratification mainly occur due to the difference in temperature between the contents of the storage tank and the heated water that flows in. The storage is generally loaded with the same temperature level as in the solar circuit. This means that although solar heat is pumped into the storage unit, mixing necessarily occurs if there is a difference in temperature. Stratified storage unit loading stations increase the amount of thermal energy that can be used when different storage tank zones are loaded, depending on the available temperature level.

STRATIFIED LOADING WITH TEMPERATURE BALANCING

Storage tank loading stations bring together the functions of the solar station and module in a pre-assembled module.

Loading stations are used to load storage tanks with solar heat by means of powerful plate heat exchangers. A temperature-based storage tank loading means that the relevant storage tank zones are loaded in accordance with the temperature level available in the solar thermal energy system.

CONTROLLER COMPARES THE COLLECTOR AND STORAGE UNIT TEMPERATURE

The electronic controller ensures that the solar-heated hot water is delivered to the storage tank at precisely the temperature available at one of two storage unit inputs. The controller evaluates the temperature differences of the primary and secondary side for this purpose.

The temperature values at the flow connections of the storage tank and in the collector determine which of the two buffer inputs is controlled.

The temperature data influences the pump speed in such a way that the hot water in the plate heat exchanger is heated to the temperature of the storage tank zone nearer to the collector temperature.

STABLE LOADING IN THE STORAGE TANK

The storage unit loading stations were developed for high energy yield in the collector and to establish stable stratification in the storage tanks without an internal heat exchanger. The electronically regulated loading station considers both the solar heat available from the collector circuit and the temperature in the storage tank.

Depending on their configuration, some storage unit loading stations for large solar energy systems allow large solar collector areas to be connected, achieving a high energy yield.

STRATIFIED STORAGE UNIT LOADING FOR TWO STORAGE TANK ZONES

The storage unit loading stations achieve a high energy yield from the collector and stable stratification in the storage unit.

BENEFITS AT THE PLANNING STAGE

- Certainty during planning and dimensioning thanks to the compact installation-ready design
- Efficient planning thanks to hydraulic design and station configuration by the manufacturer
- Can be combined with a wide variety of heat generator and storage systems
- The compact design makes planning easier
- Costs can be kept under control during planning thanks to a clear, pre-configured component specification
- Enables the planner to position himself as an innovator

BENEFITS AT THE INSTALLATION STAGE

- Less time required to install, commission and maintain the system
- Increased sales
- Service and guarantee from a single source
- Reliable operation thanks to high quality components
- Compact design means that less space is required for installation
- Easy to provide evidence of energy yield
- Satisfied customers
- Enables the fitter to position himself as an innovator

TacoSol Load storage loading station

Solar station and loading module (system separation) in one:

- Connection-ready storage loading stations with integrated system separation for loading one or two storage tank or domestic water storage heating units by means of a solar thermal energy system
- Maximum solar yield and efficient operation thanks to sensor technology
- Ideally complements the TacoTherm Fresh fresh hot water stations

Product photo	Series	Heat output * ¹⁾	Collector surface * ²⁾	Comments
	Mega	12.5 kW	Approx. 25 m ²	<ul style="list-style-type: none"> ▪ Solar station with permanent automatic venting ▪ External heat exchanger for loading a storage tank at one or two levels

*¹⁾ according to VDI 6002

*²⁾ depends on overall pressure loss of solar circuit including collector

TACOSOL LOAD MEGA

STORAGE LOADING STATION



ADVANTAGES

- Maximum solar yield from the roof to the storage tanks owing to high-quality stainless steel plate heat exchanger
- Zone-based loading of one storage tank or loading of two storage tanks
- Speed control of the primary and also secondary pump for optimal temperature differentiation
- Stable stratified loading in the storage tank
- TacoControl Tronic for recording the primary return temperature and the primary flow rate
- Maximum energy efficiency, for example for generating fresh hot water with the TacoTherm Fresh fresh water stations

Connection-ready storage loading station with high-efficiency pumps for efficient thermal transfer of solar energy to one or two storage tanks

DESCRIPTION

The TacoSol Load Mega storage loading station performs the zone-based loading of one storage tank or loading of two storage tanks via a thermal solar installation according to the available flow temperature.

INSTALLATION

The station is fully preassembled, connection-ready and can be fitted directly to the storage tank or to the wall. Only the storage and collector sensors as well as the ventilating safety unit have to be assembled.

OPERATION

The TacoSol Load Mega is a compact loading station equipped with EPP design insulation for loading one or two storage tanks by means of a solar system.

The solar energy recovered is transferred via a high-efficiency stainless steel plate heat exchanger to the storage tank(s). By controlling the speed of the primary and also the secondary pump, the integrated controller ensures the optimal conditions are in place for achieving the best possible solar yield.

The parameters required for this purpose for the TacoSol Load Mega L with switching valve are determined, for example, by means of TacoControl Tronic. The controller regulates the three-way switching valve to operate either storage inflow 1 or 2. This ensure optimal loading of one or more storage tanks.

BUILDING CATEGORIES

- Single family homes, multiple dwelling units
- Hotels and restaurants
- School buildings and sports facilities
- Industrial buildings and systems

EXPANSION OPTION

The TacoTherm Fresh Mega and TacoTherm Fresh Tera fresh water stations ideally complement the innovative TacoSol Load Mega zone-based storage loading system. They are used for hygienic fresh water preparation.

SYSTEM/BASIC DIAGRAM

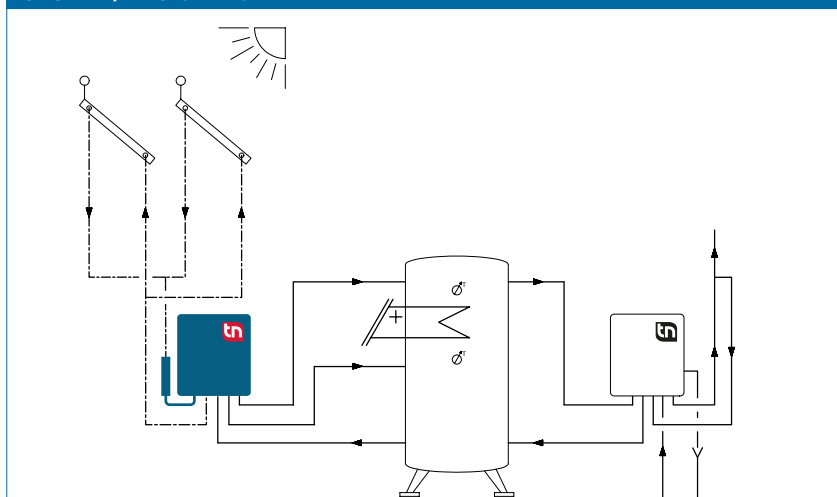

SPECIFICATION TEXT

See www.taconova.com

TECHNICAL DATA

General

- Controller with display
- Weight (empty): approx. 12 kg
- Overall dimensions (incl. hood):
W 698.5 mm × H 636 mm × D 181 mm

Material

- Designer hood made from EPP
- Pumps: Cast iron
- Valve housing: Brass
- Pipes: Stainless steel 1.4404
- Plate heat exchanger:
Stainless steel
- Plates and connector pieces:
Stainless steel 1.4401
- Solder: 99.99 % copper
- Seals: AFM34 (flat sealing)

Primary side

- Operating temperature $T_{0 \text{ max}}$:
 - Flow: 110 °C, briefly (2h): 140 °C
 - Return: 95 °C
- Max. operating pressure $P_{0 \text{ max}}$: 6 bar
- Primary pump:
WILO Yonos Para ST 15/7.5
- Ventilator group with integrated
shutoff, filling, purging and drainage
facility
- Safety valve 6 bar
- TacoControl Tronic measurement
range: 2 – 40 l/min

Secondary side

- Operating temperature $T_{0 \text{ max}}$: 110 °C
- Max. operating pressure $P_{0 \text{ max}}$: 3 bar
- Secondary pump: WILO Yonos Para
ST 15/7.5
- Zone switching valve

Performance data

- See design diagram

Electrical connection data

- Mains voltage: 230 VAC ± 10 %
- Mains frequency: 50...60 Hz
- Power consumption of station:
max. 130 W
- Power consumption of pump:
solpump: 4-75 W
- Power consumption of pump in
standby mode: 0.8 W
- Fuse 2 AT
- Protection type: IP 40

Flow media

- Heating water
(VDI 2035; SWKI BT 102-01;
ÖNORM H 5195-1)
- Typical glycol mixtures up to 40%

TYPE OVERVIEW

TacoSol Load Mega | Storage loading station

Order no.	Rp	Version	Version
271.5512.000	¾" IG	L	with switching valve
271.5511.000	¾" IG		without switching valve

DIMENSIONAL DRAWING

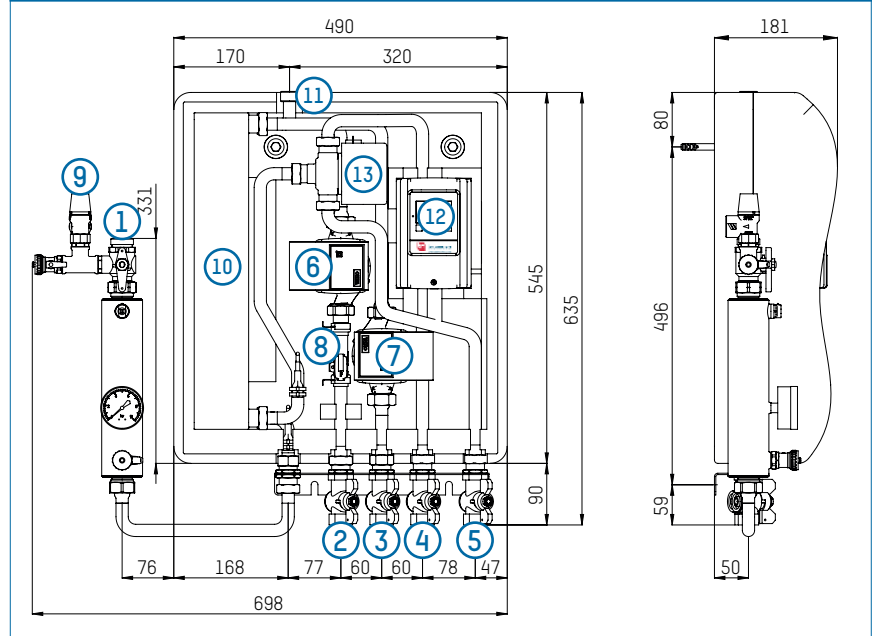

HYDRAULIC DIAGRAM

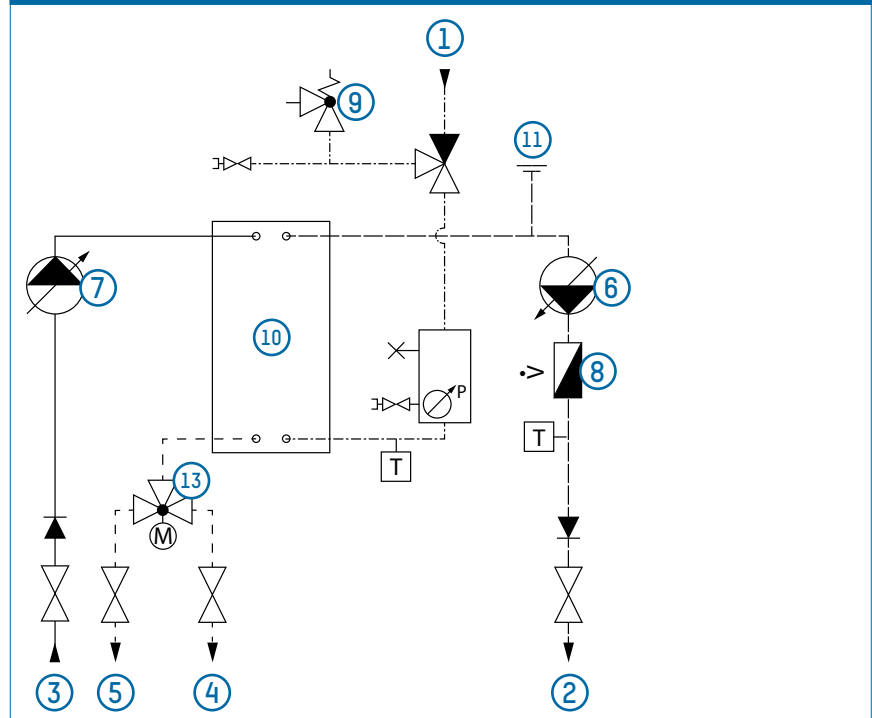

- | | |
|--------------------------------------------------------------|------------------------------------------|
| 1 Primary – solar flow | 7 Secondary storage loading pump |
| 2 Primary – solar return | 8 Flow rate sensor |
| 3 Secondary – storage return | 9 Solar safety valve |
| 4 Secondary – storage flow 1 | 10 Heat exchanger |
| 5 Secondary – storage flow 2
(optional zu Umschaltventil) | 11 Connection of expansion vessel |
| 6 Primary solar pump | 12 Regulator |
| | 13 Switching valve (TacoSol Load Mega L) |

CHARACTERISTIC OF PLATE HEAT EXCHANGER

BASICS

Calculation values 500 [W/m²]

LEGEND / EXPLANATION

ΔT <5K Efficient operation

ΔT 5-7K Reduced yield

ΔT >7K Considerably reduced yield

AVERAGE LOG TEMP DIFFERENCE [LOG DELTA T]

Spec. flow rate
[l/(h*m²)]

Collector surface (m²)

Spec. flow rate [l/(h*m ²)]	Collector surface (m ²)			
	5	10	15	20
10	7.6	8.4	8.5	9.5
25	3.6	4.3	5.5	6.0
35	2.8	4.2	4.5	5.0
50	2.2	3.4	3.7	4.0

FLOW AND PRESSURE LOSS DIAGRAMS

A) Pump characteristic

System characteristic primary side

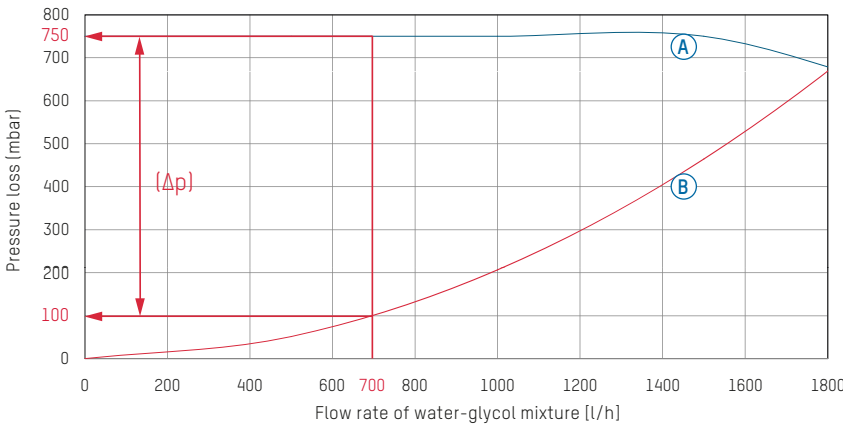

B) Pump characteristic

System characteristic secondary side

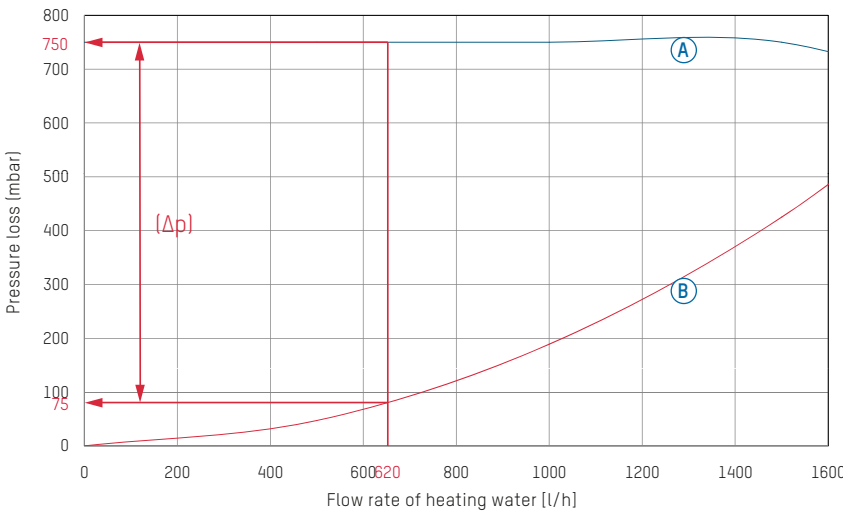

A Pump characteristic | B System characteristic

EXAMPLE OF INTERPRETING THE DIAGRAMS

Given

- Collector surface: 20 m²
- Output: 12.5 kW
- Average log temp difference: 5.0
- Spec. flow rate 35 l/h × m²

Sought

- Residual pump head primary circuit
- Residual pump head secondary circuit

Approach

- The primary flow rate of 700 l/h is calculated based on: Collector surface × Specific flow rate
- In Diagram A) the primary pressure loss at the intersection point of the system characteristic is 100 mbar.
- The residual pump head is 750 mbar. Discounting the pressure loss this gives rise to a residual pump head of 650 mbar (Δp).
- In Diagram B) the primary flow rate is 620 l/h. The difference between the flow rates is based on the different thermal capacities of the heating water on the secondary side and the ethylene-glycol mixture on the primary side.
- The secondary pressure loss at the intersection of the system characteristic is 75 mbar.
- The residual pump head is 750 mbar. Discounting the pressure loss this gives rise to a residual pump head of 670 mbar (Δp).

EFFICIENT AND SAFE USE OF REGENERATIVE ENERGIES

Safety and efficiency are the key criteria when installing and operating solar thermal energy systems.

EFFICIENT OPERATION OF THE SOLAR THERMAL SYSTEM

When used in conjunction with conventional heating systems, regenerative energy systems secure the thermal energy requirements of buildings. Special requirements apply when integrating solar thermal systems. In addition to intrinsically safe operation, the efficient transfer of solar heat from the collector to the thermal storage station is an important criterion.

The efficient operation of the solar thermal system largely depends on the system being correctly ventilated and the performance-specific adjustment of volume flow.

INTRINSIC SAFETY OF SOLAR THERMAL SYSTEMS

Solar stations link the collector circuit to the solar storage tank. The most important functions are pumping, regulating and ventilating in order to ensure safe and efficient operation of the system under all operating conditions. Thus, the function of a solar station is not just to circulate the solar fluid, but also:

Demand-driven volume flow regulation

- to protect against circulatory malfunctions
- to protect the components from overpressure
- to monitor the temperature
- to separate the air

In addition, the solar station makes it easier to perform maintenance tasks when filling and emptying the various circuits by means of the integral multifunctional valves.

PROTECTION AGAINST STEAM AND CAVITATION

One of the design features of the TacoSol Circ solar station is the connection for the solar expansion vessel on the intake side in front of the pump. This prevents a negative operating pressure (underpressure) from building up in front of the pump, thus ensuring that the expansion vessel and circulating pump are protected from cavitation.

AUTOMATIC AIR SEPARATION

It is necessary to ventilate the solar circuit after it is first filled and during ongoing operation. Air pockets impair the operation of the system, reduce solar yield and also cause the solar fluid to age prematurely.

The TacoSol Circ solar station has an integrated ventilating flask with built-in manometer, the innovative design of which ensures automatic air separation both when filling the system and during ongoing operation. This makes it possible to ventilate and check the pressure of the solar circuit directly at the station. This saves time when commissioning and maintaining the solar station.

VALVE AND PUMP GROUP FOR THE INTRINSICALLY SAFE OPERATION OF SOLAR STATIONS

As a compact, preassembled valve group, the TacoSol Circ solar station brings together the most important regulating and safety components, such as circulating pump, safety valve, non-return valve, flow rate control, ventilating flask, manometer and thermometer.

SAFE USE OF SOLAR ENERGY

The pre-assembled, pre-configured components in the solar stations make it easier to plan, install and efficiently operate the solar thermal energy system.

BENEFITS AT THE PLANNING STAGE

- Certainty during planning and dimensioning thanks to pre-assembled main components
- Efficient planning thanks to hydraulic pre-dimensioning and station configuration
- Costs can be kept under control during planning thanks to preconfigured stations and clear component specification
- The compact design makes planning easier
- Enables the planner to position himself as an innovator



BENEFITS AT THE INSTALLATION STAGE

- Less time required to install, commission and maintain the system
- Increased sales
- Service and guarantee from a single source
- Reliable operation thanks to high quality components
- Compact design means that less space is required for installation
- Easy to provide evidence of energy yield
- Satisfied customers
- Enables the fitter to position himself as an innovator

TacoSol Circ Solar stations

Connection-ready, fully assembled pump groups for direct installation in the solar circuit of solar power systems.

- Hydraulic balancing and flow measurement and control can be carried out directly on the solar station in all versions
- Permanent, automatic air separation in the integrated ventilating flask (mounted on intake side upstream of the pump on the expansion vessel connection)

Product photo	Station / Type	Version	Circulating pump type	Comments
	TacoSol Circ ER HE	Single-line	High-efficiency pump	▪ Available with or without safety subassembly
	TacoSol Circ ZR HE	Two-line	High-efficiency pump	▪ Available with cover plate or support for controller

TACOSOL CIRC ER HE

SINGLE LINE SOLAR STATION



Pump assembly with high-efficiency pumps, balancing valve and optional safety subassembly for solar heating energy systems.

DESCRIPTION

Hydraulic balancing and flow measurement can be carried out directly on the station in the case of the TacoSol Circ ER HE solar station. The integrated TacoSetter Inline 130 allows the volume flow in the primary circuit to be precisely and conveniently adjusted and checked. Systems that are correctly balanced hydraulically ensure optimal energy transfer from the collector panel to the heat storage unit and therefore allow economical operation of the solar system.

Using scales that are pre-calibrated for inhibitors, specialists locally can adjust and check the flow values. Training and costly measuring devices are no longer needed.

INSTALLATION POSITION

The solar station must be installed vertically. The installation can be carried out by a single installer.

ADVANTAGES

Compact

- Equipped with all the necessary valves and components

Simple

- Hydraulic balancing and functional checking of the system with TacoSetter Inline 130
- Pump can be changed with ease as it is lockable on the intake and output sides
- Simple filling, draining and servicing of the system owing to multifunctional ball valve

Efficient

- Highly efficient system operation owing to permanent air separation with use of HE pumps

Flexible

- Flexibility thanks to the option of integrating control systems

OPERATION

In combination with a solar controller, the solar station transports the solar liquid heated in the collector to the hot water/drinking water storage tank via a heat exchanger.

The integrated TacoSetter Inline 130 balancing valve enables the volume flow to be adjusted to the performance of the collector or heat exchanger and checked.

The flow measurement of this balancing valve is based on the principle of a float. The regulating screw on the flow meter is used to adjust the flow. The reading position is the lower edge of the float element.

BUILDING CATEGORIES

- Apartments, apartment blocks
- Single family homes, housing estates
- Multiple dwelling units

SYSTEM/BASIC DIAGRAM

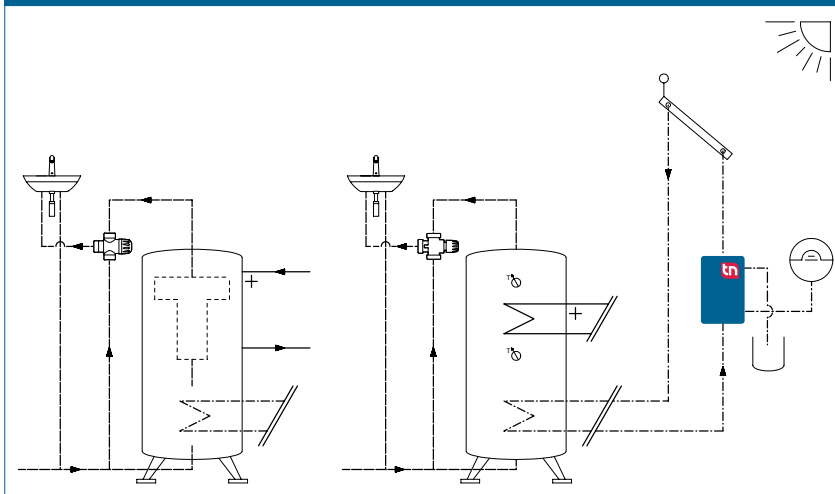

SPECIFICATION TEXT

See www.taconova.com

TECHNICAL DATA

General

- Max. operating temp. $T_{0\ max}$: 110 °C
- Max. operating pressure $P_{0\ max}$: 6 bar
- Safety valve: 6 bar
- k_{VS} value and measurement range according to „Type overview“ table
- Thread according to DIN 2999/ISO 7 and ISO 228
- Measuring accuracy $\pm 10\ %$ of the final value
- Solar circuit pump: TacoFlow3 GenS Solar 15-85/130 C3 AS N

Material

- Valve housing: Brass
- Internal parts: Stainless steel, brass, plastic; borosilicate (sight glass)
- O-ring seals: FKM
- Flat seals: AFM34
- Insulation: EPP

Electric connection data

- TacoFlow3 GenS Solar 15-80/130
 - Mains voltage: 230 VAC $\pm 10\ %$
 - Mains frequency: 50/60 Hz
 - Power consumption:
 - Speed P1 [W] min. 3 // max. 50
 - I1/I [A] min 0.05 max. 0.44
 - Protection class: IPX4D
 - $EEL \leq 0.20$

Fluids

- Water mixtures with typical additives used against corrosion and freezing (display scale for medium viscosity $\nu = 2,3\ mm^2/s$)
- Heating water (VDI 2035; SWKI BT 102-01; ÖNORM H 5195-1)
- Cold water

TYPE OVERVIEW

TacoSol Circ ER HE | Single line design with safety subassembly with high-efficiency circulating pump

Order no.	$k_{VS}^{1)}$	Measuring range ²⁾
270.2006.345	1.5	1,5 – 6,0 l/min
270.2016.345	3.3	4,0 – 16,0 l/min
270.2028.345	3.5	8,0 – 28,0 l/min

¹⁾ k_{VS} [m³/h] at $\nu = 1\ mm^2/s$

²⁾ Reading scale for water-glycol mix with $\nu = 2,3\ mm^2/s$

DIMENSIONAL DRAWING

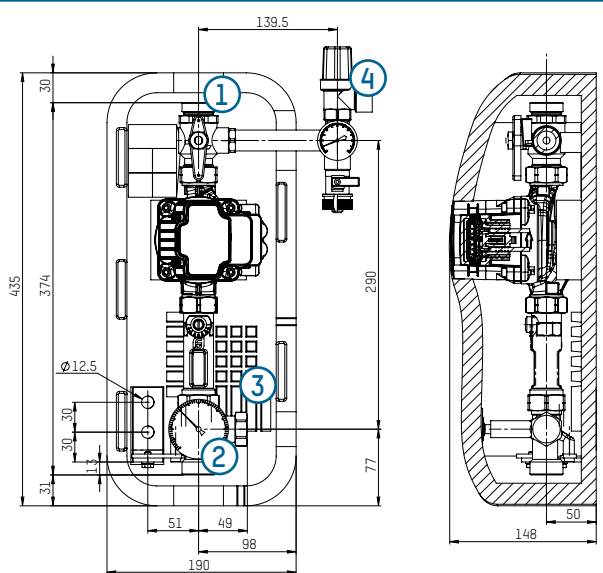

- 1 Connection of collector return (AG ISO 228, G 1" flat sealing and cutting ring)
- 2 Connection of storage return (AG ISO 228, G 1" flat sealing and cutting ring)
- 3 Connection of expansion vessel (AG ISO 228, G 3/4" flat sealing and cutting ring)
- 4 Connection of safety valve drainage line (IG DIN 2999 / ISO 7, Rp 3/4")

PUMP CHARACTERISTIC

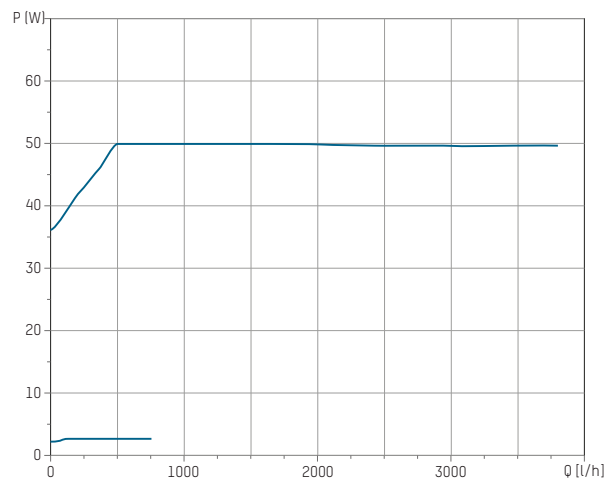
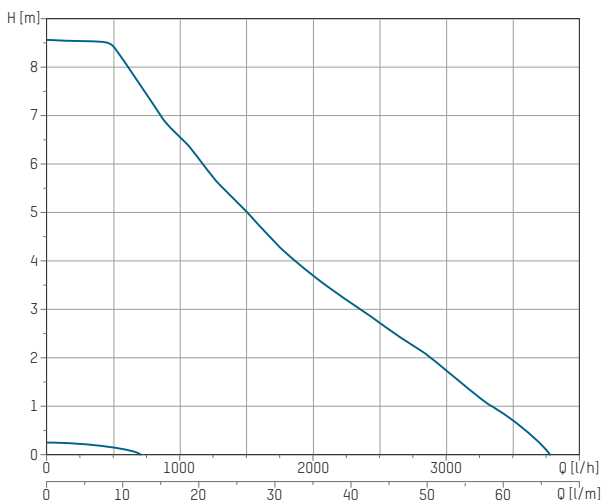

PRESSURE LOSS DIAGRAMS

270.X006.XXX (DN 20 | 1" | 1,5...6 l/min)

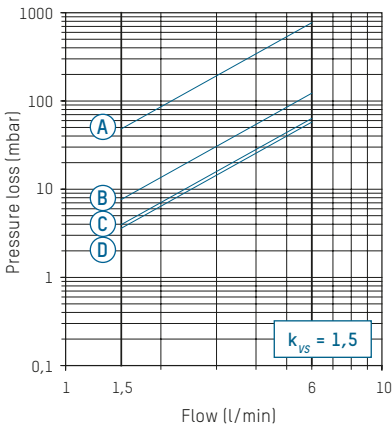

270.X016.XXX (DN 20 | 1" | 4...16 l/min)

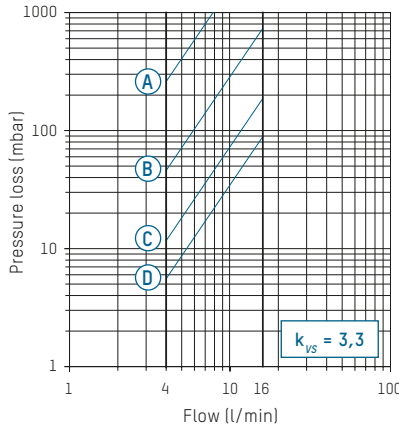

270.X028.XXX (DN 20 | 1" | 8...28 l/min)

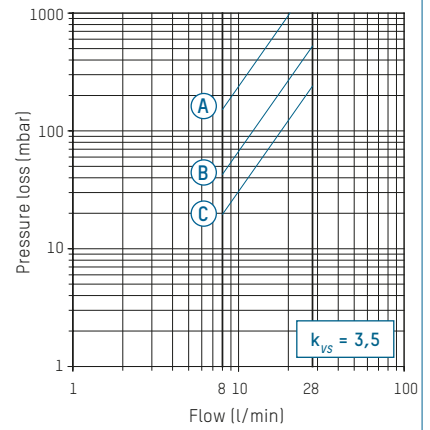

A - D Return characteristics of valve position for TacoSetter Inline 130

ACCESSORIES



SOLDER JOINT PRESSURE FITTING

Flat sealing connector joint, consisting of a soldered connecting nipple, lock nut and flat seal suitable for solar technology

Order no.	G x mm	Version for
210.5331.019	1" x 18 mm	Copper pipe 18 mm
210.5332.019	1" x 22 mm	Copper pipe 22 mm



FILL AND DRAIN COCK 3WAY CONNECTOR

For connection to the expansion vessel connector piece, consisting of a T- joint with fill and drain cock, lock nut with G 3/4" internal thread with flat seal suitable for solar technology, G 3/4" outer thread connector.

Order no.	DN	G
296.7001.354	20	3/4"



EXPANSION VESSEL MOUNTING BRACKET WITH QUICK ACTION COUPLING

For mounting the expansion vessel on the wall with quick-action shut-off coupling 1 x internal thread, 1 x external thread G 3/4".

Order no.	DN	G
296.7002.000	20	3/4"



STAINLESS STEEL TUBE

For connecting the expansion vessel, incl. 3/4" lock nut and flat seals suitable for solar technology.

Order no.	DN	G	Length
296.7003.000	20	3/4"	0,5 m

TACOSOL CIRC ZR HE

TWO-LINE SOLAR STATION



Two-line pump assembly with high-efficiency pumps, balancing valve, ventilation unit and safety subassembly for solar heating energy systems

DESCRIPTION

Hydraulic balancing, flow measurement and ventilation can be carried out directly on the station in the case of the TacoSol Circ ZR HE solar station. The integrated TacoSetter Inline 130 allows the volume flow in the primary circuit to be precisely and conveniently adjusted and checked. Permanent air separation in the integrated ventilating flask allows energy-efficient operation of the system. Systems that are correctly balanced hydraulically and air-free guarantee optimal energy extraction and are thus more cost-effective in the sense of the energy-saving directives laid down by law.

Using scales that are pre-calibrated for inhibitors, specialists locally can adjust and check the flow values. Training and costly measuring devices are no longer needed.

INSTALLATION POSITION

The solar station must be installed vertically to ensure that the ventilation unit functions correctly. Installation and ventilation can be performed by a single installer.

ADVANTAGES

- **Compact:** Equipped with all the necessary valves and components
- **Secure:** Intrinsic safety of the system thanks to an integrated safety subassembly
- **Simple:** Hydraulic balancing and functional checking of the system with TacoSetter Inline 130. Pump can be changed with ease as it lockable on the intake and output sides
- **Efficient:** Highly efficient system operation owing to permanent air separation and use of high-efficiency pumps
- **Flexible:** Flexibility thanks to the option of integrating control systems

OPERATION

In combination with a solar controller, the solar liquid heated in the collector is transported to the hot water/drinking water storage tank via a heat exchanger with the help of the solar station.

The integrated TacoSetter Inline 130 balancing valve enables the volume flow to be adjusted to the performance of the collector or heat exchanger and checked. The flow measurement of this balancing valve is based on the principle of a float. The regulating screw on the flow meter is used to adjust the flow. The reading position is the lower edge of the float element.

The integrated ventilating flask with innovative flow technology design ensures permanent air separation and thereby increases the efficiency of the system.

BUILDING CATEGORIES

- Apartments, apartment blocks
- Single family homes, housing estates
- Multiple dwelling units

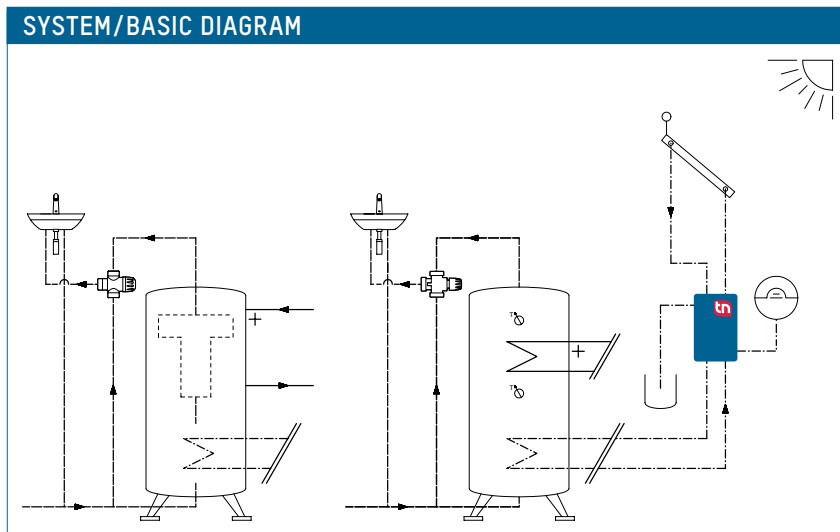

SPECIFICATION TEXT

See www.taconova.com

TECHNICAL DATA

General

- Maximal operating temperatures:
 - Flow line (ventilator side) $T_{0\ max}$: 150 °C
 - Return line (pump side) $T_{0\ max}$: 110 °C
- Max. operating pressure $P_{0\ max}$: 6 bar
- Safety valve: 6 bar
- k_{VS} value and measurement range according to „Type overview“ table
- Thread according to DIN 2999/ISO 7 and ISO 228
- Measuring accuracy $\pm 10\ %$ of the final value

Material

- Vent pipe: Painted steel
- Valve housing parts: Brass
- Internal parts: Stainless steel, brass and plastic, borosilicate (sight glass)
- O-ring seals: FKM
- Flat seals: AFM34
- Insulation: EPP

Electric connection data

- TacoFlow3 GenS Solar 15-85/130 C3 AS N:
 - Mains voltage: 230 VAC $\pm 10\ %$
 - Mains frequency: 50/60 Hz
 - Power consumption:
 - Speed P1 [W] min. 3 // max. 50
 - I1/I [A] min 0.05 max. 70 0.44
 - Protection class: IPX4D
 - EEI ≤ 0.20

Fluids

- Water mixtures with typical additives used against corrosion and freezing (display scale for medium viscosity $\nu = 2,3\ mm^2/s$)
- Heating water (VDI 2035; SWKI BT 102-01; ÖNORM H 5195-1)
- Cold water

TYPE OVERVIEW

TacoSol Circ ZR HE | Two-line design with high-efficiency pump

Version with carrier for controller

Order no.	$k_{VS}^{1)}$	$k_{VS}^{2)}$	Measuring range ³⁾
270.2506.356	1,5	6,0	1,5 – 6,0 l/min
270.2516.356	3,3	6,0	4,0 – 16,0 l/min
270.2528.356	3,5	6,0	8,0 – 28,0 l/min

TacoSol Circ ZR HE | Two-line design with high-efficiency pump

Version with cover plate

Order no.	$k_{VS}^{1)}$	$k_{VS}^{2)}$	Measuring range ³⁾
270.2506.000	1,5	6,0	1,5 – 6,0 l/min
270.2516.000	3,3	6,0	4,0 – 16,0 l/min
270.2528.000	3,5	6,0	8,0 – 28,0 l/min

¹⁾ k_{VS} [m³/h] at $\nu = 1\ mm^2/s$ in the return line (pump side)

²⁾ k_{VS} [m³/h] at $\nu = 1\ mm^2/s$ in the flow line (ventilator side)

³⁾ Reading scale for water-glycol mix with $\nu = 2,3\ mm^2/s$

DIMENSIONAL DRAWING

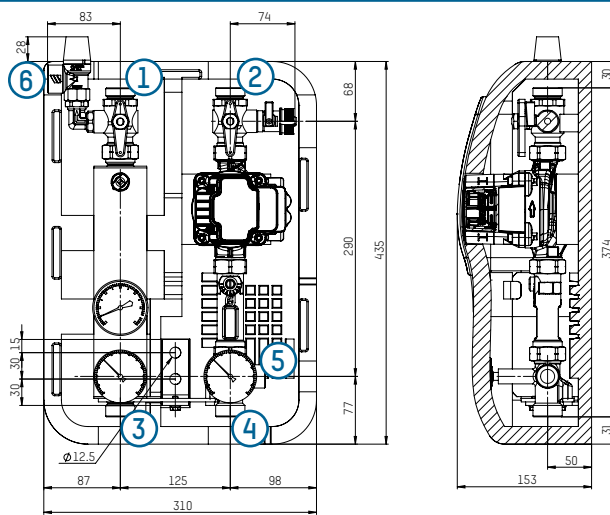

- 1 Connection of collector flow (AG ISO 228, G 1" flat sealing and cutting ring)
- 2 Connection of collector return (AG ISO 228, G 1" flat sealing and cutting ring)
- 3 Connection of storage flow (AG ISO 228, G 1" flat sealing and cutting ring)
- 4 Connection of storage return (AG ISO 228, G 1" flat sealing and cutting ring)
- 5 Connection of expansion vessel (AG ISO 228, G 3/4" flat sealing and cutting ring)
- 6 Connection of safety valve drainage line (IG DIN 2999 / ISO 7, Rp 3/4")

PUMP CHARACTERISTIC

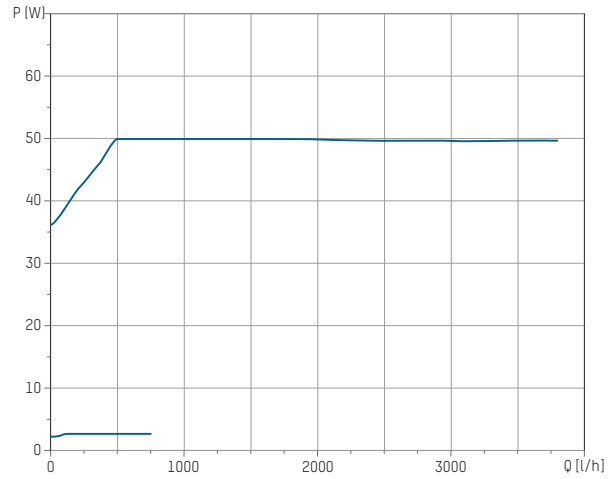
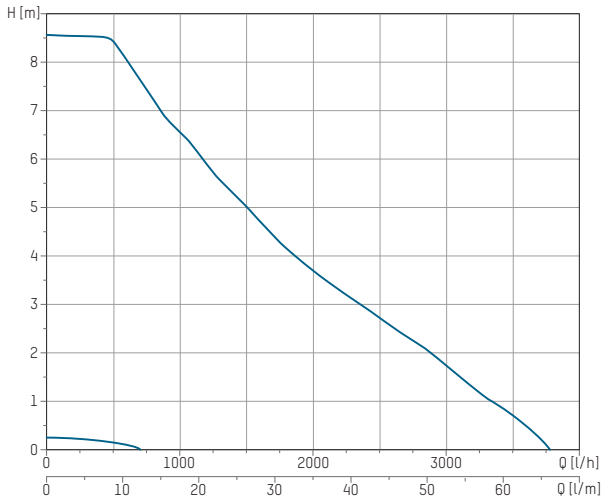

PRESSURE LOSS DIAGRAMS

270.X506.XXX (DN 20 | 1" | 1,5...6 l/min)

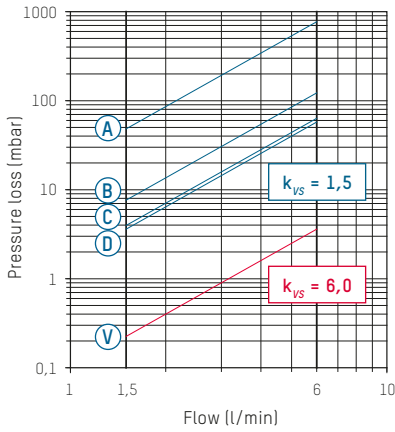

270.X516.XXX (DN 20 | 1" | 4...16 l/min)

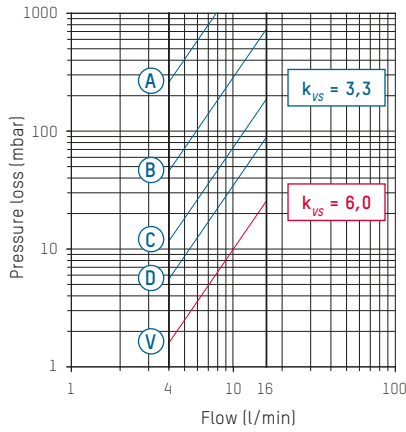

270.X528.XXX (DN 20 | 1" | 8...28 l/min)

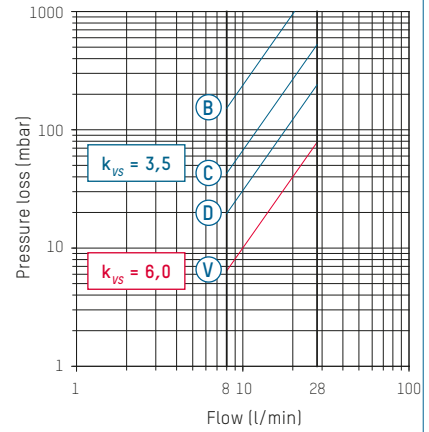

A - D Return characteristics of valve position for TacoSetter Inline 130
 V Flow characteristic (vent line)

COMPONENTS

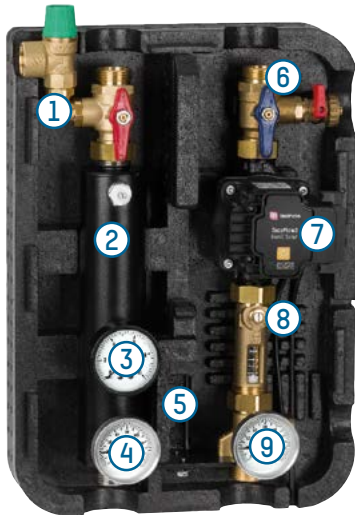

1 Shutoff ball valve with safety valve and integrated backflow preventer

- Integrated backflow preventer and check valve
- Option of lead sealing to protect against incorrect operation by the handle
- Safety valve function in each ball valve position guaranteed in accordance with safety standards

2 Ventilating flask with ventilating valve

- Permanent air separation
- Air collection volume 2.5 dl
- Integrated manual air vent for ventilating and checking the leak tightness

3 Manometer

- Display range 0-10 bar

4 Thermometer

- Display range 0-160 °C
- Dipping sensors installed in the safety pipe

5 Wall mounting

6 Shutoff ball valve with integrated backflow preventer as well as filling and draining valve

- Multifunctional valve for filling, draining and shutting off the collector circuit
- Hose connection outer thread G 3/4"
- Option of lead sealing to protect against incorrect operation by the handle

7 Circulation pump solar version

- TacoFlow3 GenS Solar 15-85/130 C3 AS N

8 TacoSetter Inline 130 balancing valve

- Sight glass with scale for medium viscosity of = 2.3 mm²/s
- Setting ranges in accordance with design
- 1.5-6 l/min | 4-16 l/min | 8-28 l/min
- Integrated shut-off function
- Hydraulic balancing of pump group without correction curves and measuring devices
- Functional checking of system at sight glass

9 Thermometer

- Display range 0-160 °C
- Dipping sensors installed in the safety pipe

Insulation and mounting accessories

- 2 hexagon wood screws 8 x 50 mm
- 2 washers
- 2 mounting pins 10 x 50 mm
- Installation instructions
- Operating and safety instructions

ACCESSORIES

**SOLDER JOINT PRESSURE FITTING**

Flat sealing connector joint, consisting of a soldered connecting nipple, lock nut and flat seal suitable for solar technology.

Order no.	G x mm	Version for
210.5331.019	1" x 18 mm	Copper pipe 18 mm
210.5332.019	1" x 22 mm	Copper pipe 22 mm

**FILL AND DRAIN COCK 3WAY CONNECTOR**

For connection to the expansion vessel connector piece, consisting of a T-joint with fill and drain cock, lock nut with G 3/4" inner thread with flat seal suitable for solar technology and G 3/4" outer thread connector.

Order no.	DN	G
296.7001.354	20	3/4"

**EXPANSION VESSEL MOUNTING BRACKET WITH QUICK ACTION COUPLING**

For mounting the expansion vessel on the wall with quick-action shut-off coupling. 1 x inner thread, 1 x outer thread G 3/4".

Order no.	DN	G
296.7002.000	20	3/4"

**STAINLESS STEEL TUBE**

For connecting the expansion vessel, incl. 3/4" lock nut and flat seals suitable for solar technology.

Order no.	DN	G	Length
296.7003.000	20	3/4"	0,5 m

**SOLAR CONTROLLER SOREL**

Order no.	Type	Application
296.7016.000	TDC 4	Version with high-efficiency pumps

**CARRIER FOR CONTROLLER**

Order no.	Application
296.7020.000	TacoSol Circ ZR HE

**COVER PLATE**

Order no.	Application
296.7021.000	TacoSol Circ ZR HE



IDEAL INTERACTION BETWEEN HEAT GENERATOR AND HEAT CONSUMER

Heating circuit pump assemblies form a unit consisting of several components, making them quick and easy to install in the heating circuit.

SPACE SAVING SUPPLY THAT ALWAYS PROVIDES THE RIGHT TEMPERATURE

The TacoHeat Mix heating circuit pump assembly can be installed on a buffer cylinder, for example, without taking up much space. In combination with a TacoSol Circ solar loading station and a TacoTherm Fresh domestic hot water station, it supplies the underfloor heating circuit manifold or radiators with the right temperature.

Products developed by Taconova are ideally matched and therefore operate perfectly with each other.

The TacoHeat Mix is also suitable for use as a link between heat generator and heat consumer, and ensures trouble-free interaction between these units.

HEATING CIRCUIT PUMP ASSEMBLIES FOR ALL HEAT GENERATOR TYPES

Pre-assembled and pre-configured components in the heating circuit pump assembly simplify the design, installation and energy efficient operation of the heating system.

BENEFITS AT THE PLANNING STAGE

- Peace of mind at the design and sizing stage due to pre-assembly of the main components
- Efficient design thanks to compact build
- Simplified room design due to compact build
- Positioning as an innovative designer

BENEFITS AT THE INSTALLATION STAGE

- Save time when installing, commissioning and servicing the system
- Service and warranty from a single provider
- Reliable operation due to high quality components
- Compact build requires little space for installation

TacoHeat heating circuit pump assemblies

Connection-ready pump assemblies for direct installation in the heating circuit of heating systems.

- Shutting off the suction and pressure sides allows easy pump replacement
- Use of a high efficiency pump

Product photo	Heating circuit pump assembly	Circulating pump type	Comments
	TacoHeat Mix	High-efficiency pump	<ul style="list-style-type: none"> ▪ Fully assembled with mixer motor and circulation pump

TACOHEAT MIX

HEATING CIRCUIT PUMP ASSEMBLY



Pump assembly with mixer, actuator, high efficiency pump and shut-off ball valves with thermometer for heating circuits

DESCRIPTION

The TacoHeat Mix pre-assembled pump assembly is suitable for heating circuits. It consists of a three-way mixer with actuator, high efficiency pump, two shut-off ball valves with integral thermometers and a non-return valve integrated into the return.

INSTALLATION POSITION

The heating circuit pump assembly must be installed vertically so that correct ventilation can be ensured. It can be installed by one person.

OPERATING PRINCIPLE

The integral three-way mixer with actuator regulates the required flow temperature to the selected set value in conjunction with the flow sensor and the consumer heating controller. The mixer has an internal bypass which ensures circulation of the return.

BENEFITS

- **Compact:** All necessary valves, accessories and components are fitted
- **Simple:** Suction and pressure sides can be shut off for simple pump replacement
- **Efficient:** High efficiency pump used with $EEL \leq 0.20$
- **Flexible:** Can be used with any heat generator

It reduces the high flow temperature from the heat generator down to the required level, which also results in an increase in the flow rate, as required for underfloor heating circuits.

This allows the actuator to operate across the entire setting range. The high efficiency circulation pump has various operating modes which can be adjusted to suit the relevant heating circuit.

The non-return valve integrated into the return prevents incorrect circulation or heat backflow.

BUILDING CATEGORIES

- Apartments, apartment buildings
- Detached houses, estates of detached houses
- Multi family homes

SYSTEM/SCHEMATIC DIAGRAM

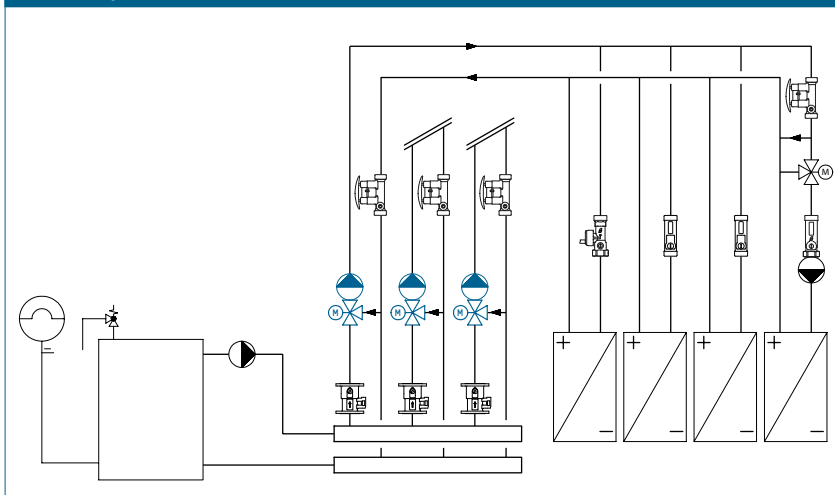

TENDER DOCUMENTATION

See www.taconova.com

SPECIFICATION

General

- Operating temperature $T_{B\ max}$: 110 °C
- Operating pressure $P_{B\ max}$: 10 bar
- k_{vs} value of mixing valve: 4 m³/h
- Flow rate: max. 1200 l/h
- Thread to DIN 2999/ISO 7 and ISO 228
- Recommended application area:
 - Radiator heating system: 2000 l/h x 15 K = 35 kW
 - Underfloor heating system: 2000 l/h x 7 K = 16 kW (11.6 kW at 5 K)

Material

- Base plate: zinc-plated sheet steel
- Back panel and cover: stylish EPP insulation
- Flow:
 - Ball valve: hot-pressed brass nickel-plated
 - Circulation pump: cast iron
 - Three-way mixer: brass
 - Servomotor housing: plastic
- Return:
 - Ball valve: hot-pressed brass nickel-plated
 - Connection pipe: plastic
 - Tee for three-way mixer: brass
 - Non-return valve: plastic
- Gaskets/seals: EPDM, PTFE

Electrical connection information

- TacoFlow2 ADAPT 15-60/130
 - Rated voltage: AC 230 V
 - Permissible voltage deviation: +10%
 - Rated frequency: 50/60 Hz
 - Power consumption: Speed P1 [W] min. 3, max. 42
I_l/I [A] min. 0.03, max. 0.33
 - Protection rating: IP 44
 - EEI ≤ 0.20
- UNI 3P rotary drive
 - Rated voltage: AC 230 V
 - Permissible voltage deviation: ± 10 %
 - Rated voltage: AC 230 V ± 10 %
 - Rated frequency: 50 Hz
 - Actuating signal: 3-point floating SPDT
 - Power consumption: 6 VA
 - Runtime: 147 s/90°
 - Torque: 15 Nm
 - Protection rating: IP 44

SPECIFICATION (CONTINUED)

Flow media

- Water mixtures with standard corrosion and antifreeze additives (indicator scale for viscosity of medium $\nu = 2.3\ \text{mm}^2/\text{s}$)
- Heating water (VDI 2035; SWKI BT 102-01; ÖNORM H 5195-1)
- Cold water

TYPE OVERVIEW

TacoHeat Mix | Heating circuit pump assembly

Part no.	Connection	Equipment level
277.2200.000	G 1" / Rp ¾"	Mixing valve, actuator and high efficiency pump

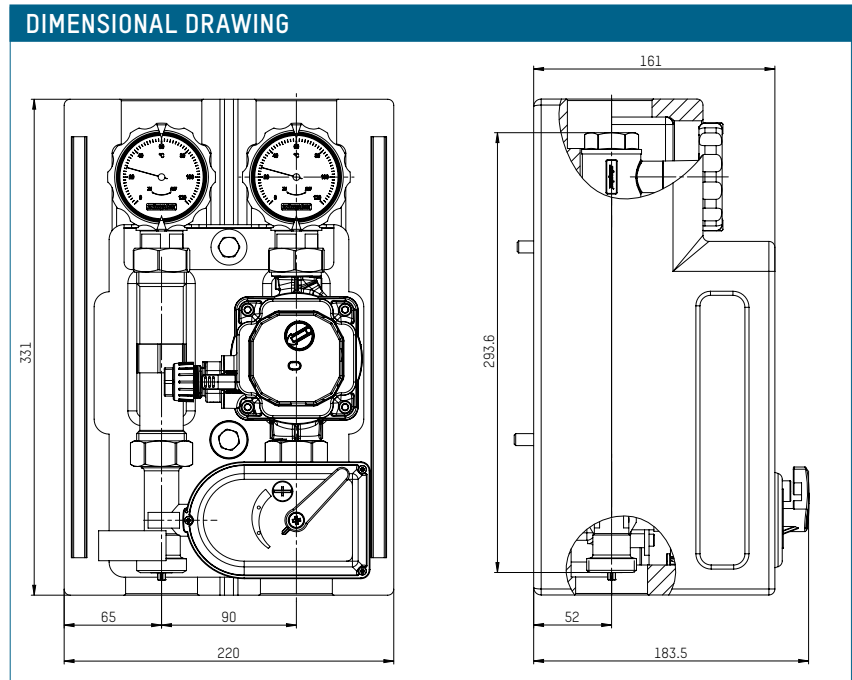

PRESSURE DROP CHART

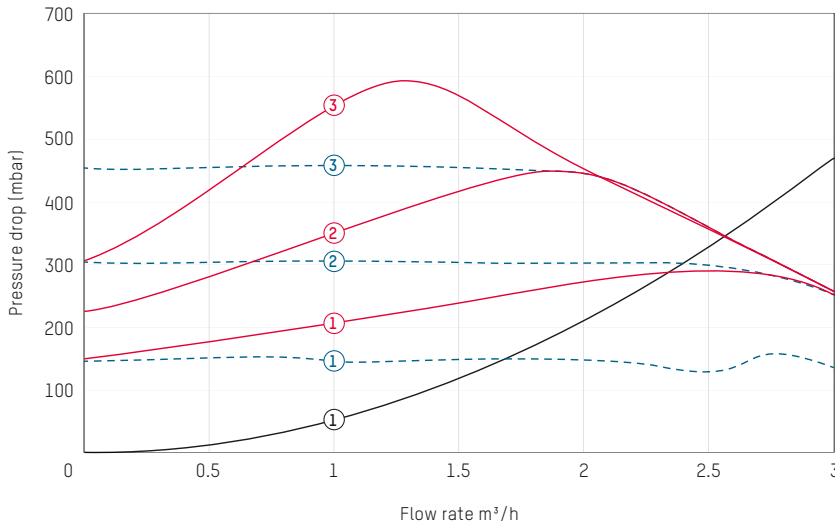

Key

- 1 Constant pressure CP1
- 2 Constant pressure CP2
- 3 Constant pressure CP3
- 1 Proportional pressure pp1
- 2 Proportional pressure pp2
- 3 Proportional pressure pp3
- 1 Pressure drop with non-return valve

COMPONENTS

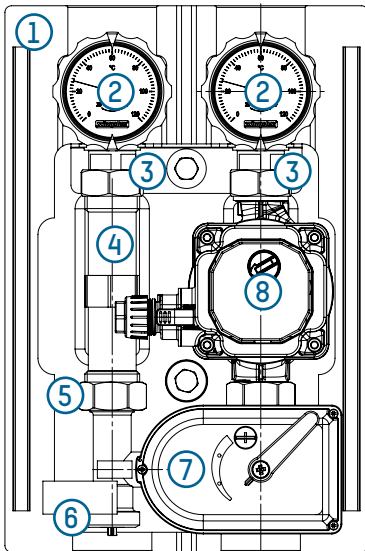

1 Wall mounting

2 Ball valve with fem. connection

- 3/4" (fem. thread), DN 20 with round thermometer bezel (red for flow; blue for return)
- Thermometer Ø: 63 mm
- Indicator range: 0 – 120 °C

3 Adaptor fittings

- 3/4" (male thread) – union nut G 1"

4 Connection pipe

- 1" (male thr. - male thr.), L = 130 mm

5 Three-way mixer

- DN 20 with integral tee

6 Non-return valve

- DN 20 Neoperl

7 Rotary drive

- FIRST UNI 3P 230 V

8 High efficiency circulation pump

- TacoFlow2 ADAPT 15-60/130, L = 130 mm

Insulation and installation accessories

- EPDM rubber seal
- Flat gasket
- 2x M12 insulating sleeves
- Washers
- 2x M8x40 hexagon bolts
- Installation instructions
- EPP insulation for pump assembly

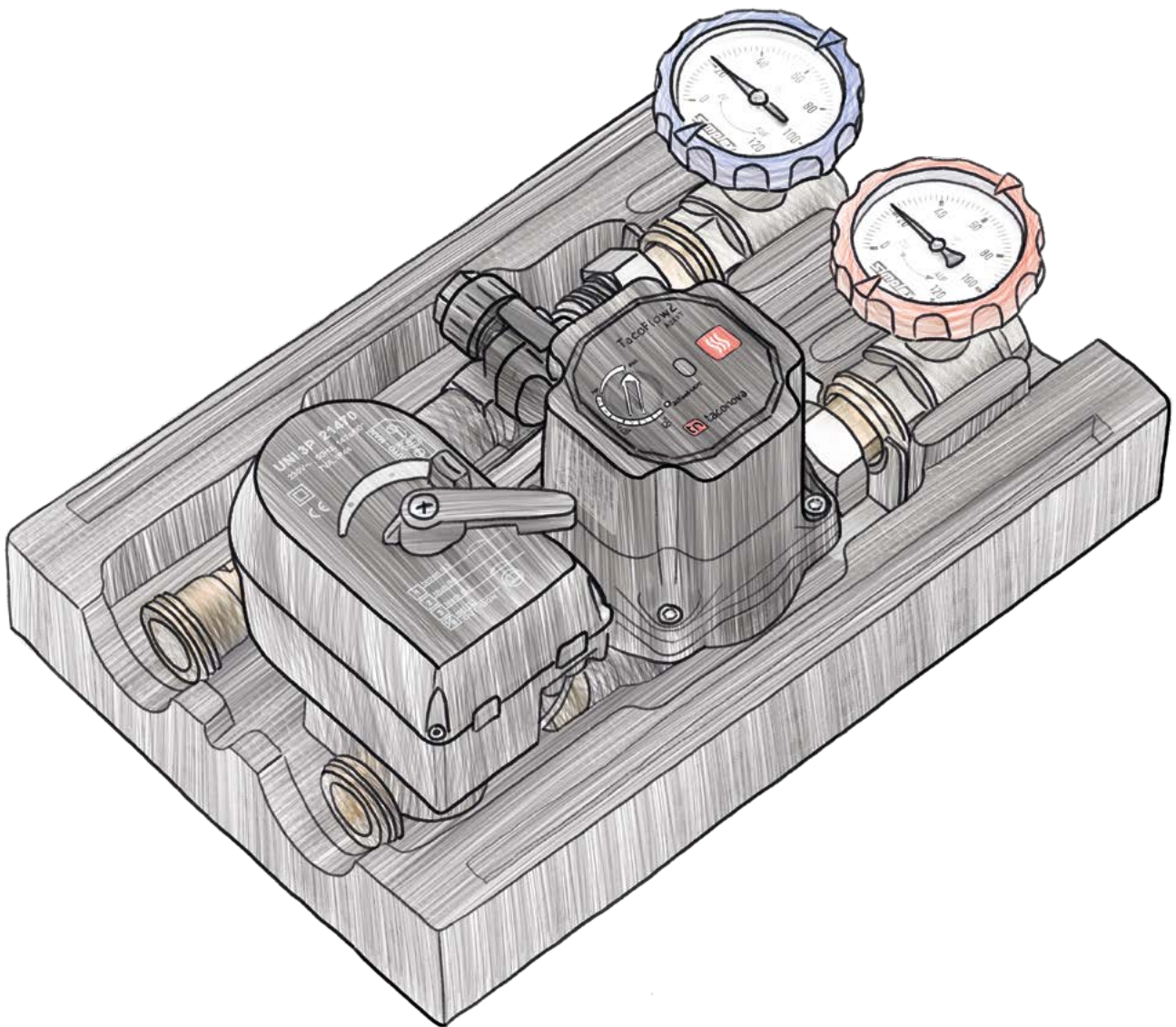

VALVES AND ACCESSORIES

A smoothly running heating or cooling system requires a large number of compact supporters. Thermal mixing valves from Taconova reduce the high domestic hot water temperatures to a constant, non-scalding temperature at the outlet. The electric zone valves NovaZone Ball and NovaZone Valve regulate the volume flows in HVAC systems. The Taconova valves and accessories vent heating systems automatically since only continuously vented and cleaned heating systems work with the greatest efficiency. Multifunctional valves and accessories for monitoring the pressure in heating systems provide additional safety.

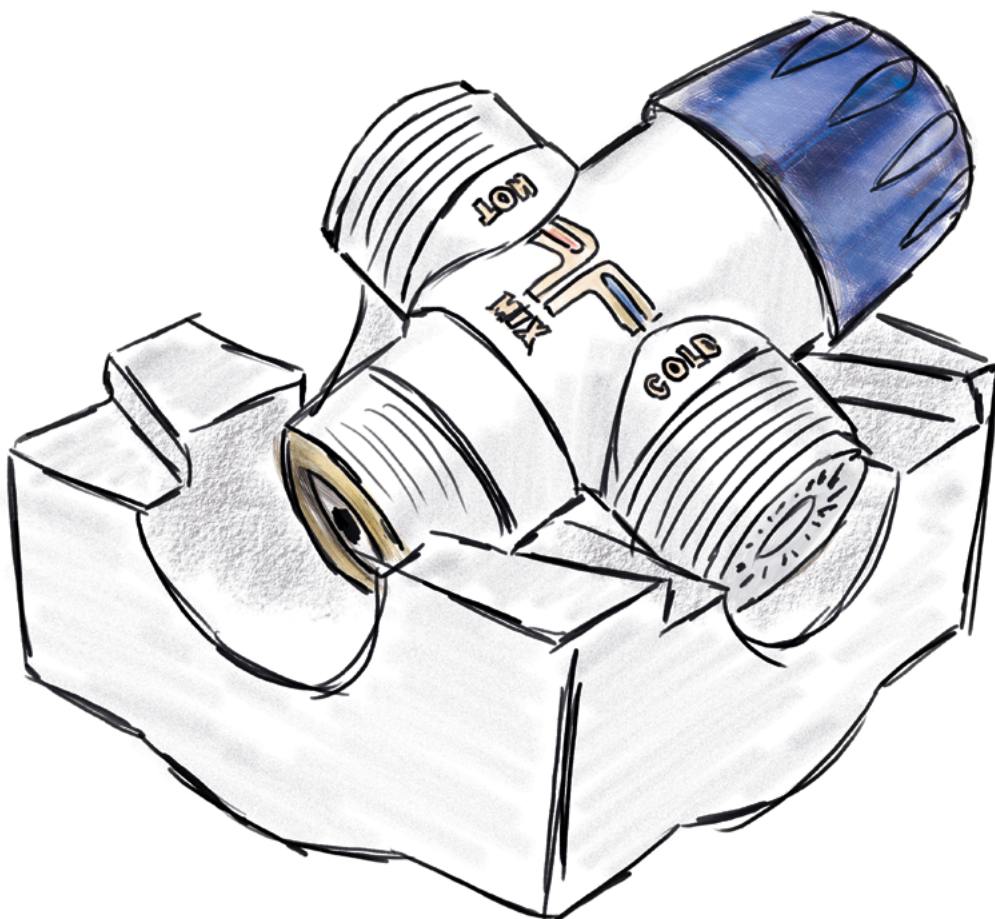

FOR THE GREATEST SAFETY IN BUILDING SERVICES

Professionally installed measuring and control valves and accessories are essential elements in the protection of people and equipment against damage. Taconova offers a wide range of top-quality products.

OVERVIEW OF PRODUCT GROUPS



THE INDEPENDENT UNIT

The thermal mixing valves from Taconova work independently and completely without auxiliary energy. The high-quality NovaMix valves are used in the solar, sanitary and heating areas – i.e., everywhere where reliably constant mixing temperatures are needed.



MEASURED FLOW

Volume flows in hydraulic heating, solar energy, sanitary and cooling systems must be controlled and regulated. The easiest way to do this is to use the electric zone valves NovaZone Ball (motor-driven ball valve) and NovaZone Valve (motor-driven valve) from Taconova. Whether the valve has a 2-way or 3-way design, Taconova has the right valve for your application.



MULTIFUNCTIONAL

The TriBloc is a compact safety group for heating systems. It combines different functions in a single valve: bleeding, ventilation, pressure indication and pressure reduction by blowing. Expansion vessels or fill/drain valves can be directly connected to the TriBloc.



THE AIR VENT

The proven automatic TacoVent air vents reliably remove unwanted air particles from heating systems. They increase efficiency and therefore reduce energy consumption and operating costs. Regardless of whether radiators or system venting, Taconova provides the ideal solution.

RELIABLE LIMITATION OF HOT WATER OUTLET TEMPERATURE

A convenient supply of hot water is closely linked with the need to have hygienic drinking water and to save energy. Measures to prevent scalding are essential in both private sanitary systems and in private homes.

PROTECTION AGAINST SCALDING IN ALL SITUATIONS

Mixing valves from Taconova cover a wide range of application areas, from single wash hand basin to central temperature limiting for large throughput volumes:

At the wash stand connection:

The NovaMix Compact mixing valve limits the hot water temperature directly at the wash hand basin connection, thereby providing effective protection against scalding in both public and private sanitary systems. This means that the hot water temperature can have high temperatures applied until directly before the dispensing point.

At the outlet of the hot water storage unit or continuous water heaters:

This type of installation offers the necessary protection against scalding in small hot water supply systems, such as detached, single family homes. The mixing valve ensures a constant and precise mixing temperature.

In large hot water supply systems:

With large throughput volumes of up to 100 l/min, the NovaMix High Capacity regulates the set temperature.

In panel heating systems:

For mixing the required flow temperature.

In renewable energy systems:

For ensuring correct loading of the storage tank when using solid fuels.

SAFE TEMPERATURE CONTROL

A fast-response thermal element in the NovaMix mixing valve ensures effective protection against scalding, precise temperature regulation and constant hot water temperatures at the dispensing point. Should the cold water feed fail, the regulating unit automatically stops the hot water feed.

Those parts of the NovaMix mixing valves that come in contact with the medium are approved for use in drinking water installations.

The internal parts have a protective layer to prevent calcification.

THERMAL DISINFECTION

For manual thermal disinfection the setting can simply be changed to maximum temperature and then back again.

MAINTAINING A CONSTANT TEMPERATURE IN HOT WATER CIRCULATION SYSTEMS

In addition to the main function for limiting the temperature, the NovaMix mixing valves can also be used to reduce energy consumption in circulation systems. For this the thermostatic mixing valve is used as a bypass between the circulation and hot water line before the water re-enters the hot water storage station. If no hot water is dispensed, the set temperature is maintained in the circulating circuit without unnecessarily pumping the water through the storage unit.

MIXING VALVE FOR TEMPERATURE ISOLATION

One possible application for cooling systems and air-conditioning systems is to use the NovaMix as a diverting valve. The valve is supplied with water from the mixing water connection and separates the medium into two temperature zones.

SAFE USE OF THE HOT WATER AT A CONSTANT TEMPERATURE

The thermostatic mixing valves from Taconova provide reliable temperature controls, meeting the requirements to prevent scalding. The automatic function of the mixing valves requires no auxiliary energy and therefore removes the need for additional regulatory components.

BENEFITS AT THE PLANNING STAGE

- Compliance with drinking water regulations
- Compliance with the Energy Conservation Act (EnEV) as no auxiliary energy is required for regulating the mixer
- Can be used for maintaining the temperature in hot drinking water systems; surface heating systems; load valves for wood-burning boilers
- Can be used as a diverting valve when water needs to be separated into two temperature zones
- Compliance with applicable design regulations for:
 - Constant hot water temperatures
 - Cold water feed failure
 - Protection against scalding

BENEFITS AT THE INSTALLATION STAGE

- Variable installation position
- Possibility to lock the set point adjustment (tamper proofing)
- Low-maintenance thanks to internal parts with non-stick coating to prevent calcification
- Backflow preventer can be integrated as an accessory
- Replaceable thermostat element
- High temperature regulation range for thermal disinfection
- Constant hot water temperatures without additional installation of sensors and regulators

Mixing valves

The reliable NovaMix mixing valves ensure constant mixing temperatures at the outlet and prevent scalding. Used in the sanitation, heating and solar thermal areas where quality and safety are required.

- NovaMix Value
- NovaMix Standard
- NovaMix High Capacity
- NovaMix Compact

APPLICATIONS

Valves and accessories from Taconova can be used in various ways in heating, air conditioning, ventilation and sanitary systems:

Heating and cooling energy generation	Heating and cooling energy distribution (Indoor temperature control)	Sanitary systems
<ul style="list-style-type: none"> ▪ Solar thermal energy ▪ Oil, gas, electricity, biomass ▪ District heating 	<ul style="list-style-type: none"> ▪ Underfloor heating ▪ Radiators ▪ Chilled and heated ceilings 	<ul style="list-style-type: none"> ▪ Fresh water

SCHEMATIC OVERVIEW OF VARIOUS APPLICATIONS

DRINKING WATER AND PANEL HEATING

DRINKING WATER AT A CENTRAL LOCATION

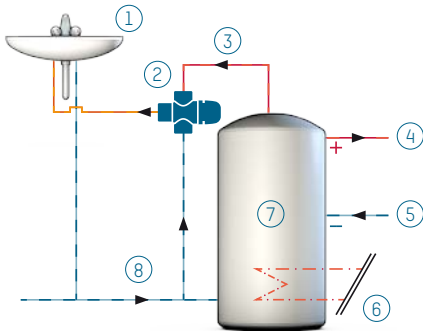

- 1 > Wash basin
- 2 > Mixing valve (Standard, Value, Compact)
- 3 > Fresh hot water output
- 4 > Heating flow
- 5 > Heating return
- 6 > Heat exchanger primary circuit
- 7 > Storage
- 8 > Cold water inlet

DRINKING WATER AT A CENTRAL LOCATION WITH SOLAR ASSISTANCE

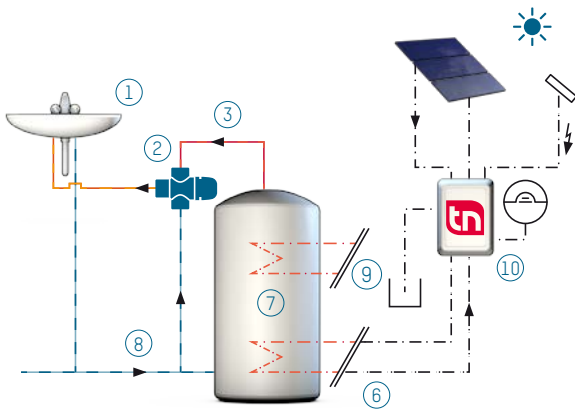

- 9 > Alternative heat source
- 10 > TacoSol Circ solar station

DRINKING WATER AT THE OUTLET

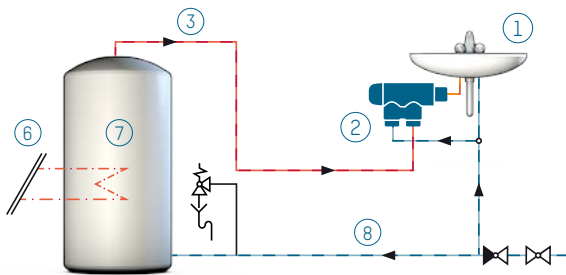

PANEL HEATING SYSTEM

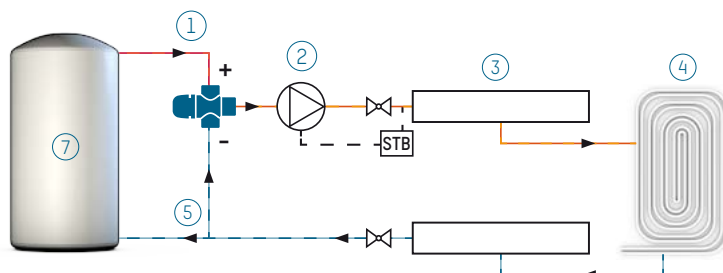

- 1 > Heating flow
- 2 > Pump
- 3 > Distributor
- 4 > Panel heating system
- 5 > Heating return

A safety temperature limiter (STB) must be installed.

STORAGE TANK LOADING WITH SOLID FUELS

FUNCTION: MIXING

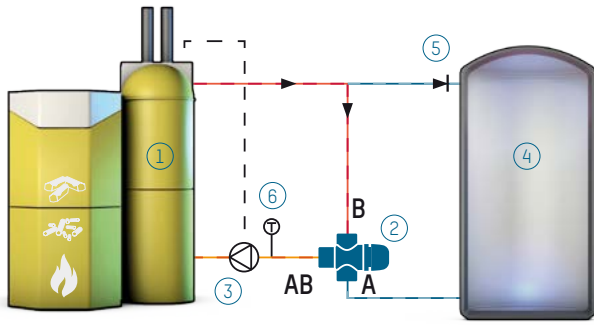

- 1 > Solid-fuel boiler
- 2 > Mixing valve
- 3 > Pump
- 4 > Storage
- 5 > Check valve
- 6 > Thermometer

FUNCTION: MIXING, STORAGE LOADING CIRCUIT

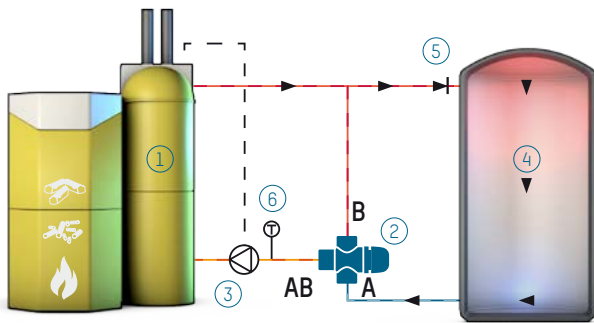

FUNCTION: DISTRIBUTING, BOILER CIRCUIT

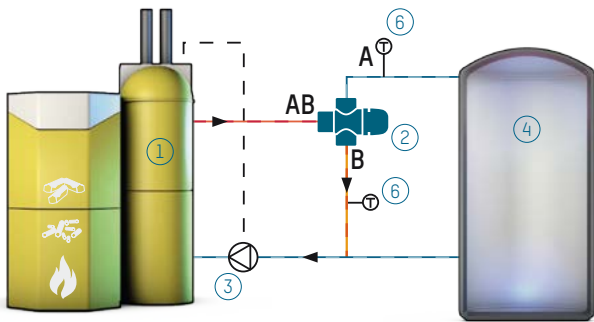

FUNCTION: DISTRIBUTING, STORAGE LOADING CIRCUIT

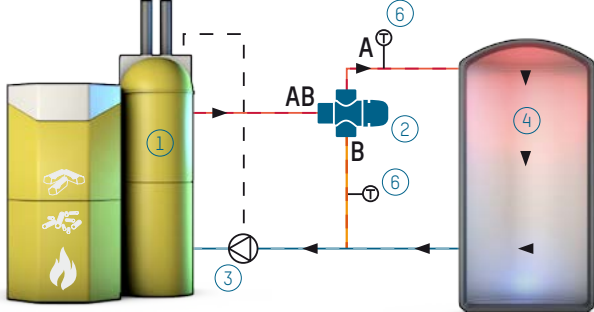

NOVAMIX RANGE OF MIXING VALVES

INFLOW	TEMPERATURE RANGE & PRODUCT	ARTICLE-NUMBER	 DRINKING WATER AT CENTRAL LOCATION		 DRINKING WATER AT CENTRAL LOCATION WITH SOLAR ASSISTANCE		 DRINKING WATER AT THE OUTLET		 PANEL HEATING SYSTEM (FLOOR, CEILING, WALL, THERMAL ACTIVATION OF BUILDING STRUCTURE)		 STORAGE LOADING (SOLID FUELS)		
			$k_{vs} < 2$	$k_{vs} > 2$	$k_{vs} < 2$	$k_{vs} > 2$	$k_{vs} < 2$	$k_{vs} > 2$	$k_{vs} < 2$	$k_{vs} > 2$	$k_{vs} < 2$	$k_{vs} > 2$	
	20 – 40 °C Standard (MT52)	252.6023.104	■				■						
		252.6024.104		■									
		252.6023.107							■				
		252.6024.107								■			
	20 – 70 °C High Capacity (MT52)	252.6034.107		■		■			■		■		
	20 – 50 °C Value	253.3002.000					■		■				
		253.3003.000						■		■			
		253.3004.000							■		■		
		253.3102.000*						■			■		
		253.3103.000*							■			■	
		253.3104.000*								■			■
	45 – 65 °C Value (MT53)	253.1002.000	■				■						
		253.1003.000		■								■	
		253.1004.000											■
		253.1102.000*		■				■					
		253.1103.000*			■								
		253.1104.000*				■							
	35 – 70 °C Value (MT53)	253.2002.000	■				■		■				
		253.2003.000		■						■		■	
		253.2004.000											■
		253.2102.000*		■				■					
		253.2103.000*			■								
		253.2104.000*				■							
	30 – 70 °C Standard (MT52)	252.6003.104	■										
		252.6003.107		■					■				
		252.6003.330*											
		252.6043.104						■					
		252.6004.104			■								
		252.6004.107				■					■		■
	30 – 50 °C Compact 50 TMV-2	252.6073.107*					■						
	30 – 70 °C Compact 70	252.6072.104*					■						

* Integrated backflow preventer (backflow preventers are not required for panel heating and check valves).

NOVAMIX VALUE

THERMOSTATIC MIXING VALVE



ADVANTAGES

- Constant temperature of the water at the outlet
- Automatic mixing function without the need for auxiliary power and infinite regulation of the mixed water temperature
- High regulation precision
- Protection against scalding
- High k_{vs} values
- Valve housing with non-stick coating to protect against lime scale deposits
- Mechanism to prevent adjustment of the nominal value
- No additional seals required when using the check valves (CV)
- Can be used in panel heating systems and for loading storage tanks by means of solid-fuel boilers

Maintaining constant mix temperatures and limiting temperatures in hot water systems

DESCRIPTION

The automatic thermostatic mixing valve NovaMix Value ensures a constant temperature of the mixed water at the outlet when used as the central mixing device.

This prevents scalding at the outlet, even with high storage tank temperatures.

Wide area of possible application thanks to three different valve dimensions. Available with $\frac{3}{4}$ " (DN15), 1" (DN20) and $1\frac{1}{4}$ " (DN25) connection. Special valve seals at the regulator piston keep undesired admixtures to a minimum*, resulting in maximum utilisation of the storage tank temperature.

The NovaMix Value is mainly used in sanitary applications as a regulating device for reducing the temperature of the water coming out of hot water storage tanks. For example as a mixing unit for constant water mixing temperatures in panel heating systems and for loading storage tanks by means of solid-fuel boilers.

* If the hot water lies 3K below the set mixing temperature, the cold water leak rate = 0. Otherwise, the maximum value for admixtures is 3K.

INSTALLATION POSITION

Any.

OPERATION

The mixing valve is supplied with hot water from the storage tank and cold water from the mains network.

The temperature of the mixed water is detected by the thermostatic expansion element. If the mixed water temperature diverges from the target value, the thermostatic expansion element moves the regulator piston, thus regulating the hot and cold water intake quantity accordingly, until the mixed water temperature corresponds to the target value.

BUILDING CATEGORIES

For pipe installations in drinking water and heating area:

- Apartment blocks, housing estates, multiple dwelling units
- Residential care facilities, hospitals
- Administration and service buildings
- Hotels and restaurants, industrial kitchens
- School buildings and sports facilities
- Commercial and industrial buildings

SYSTEM/BASIC DIAGRAM

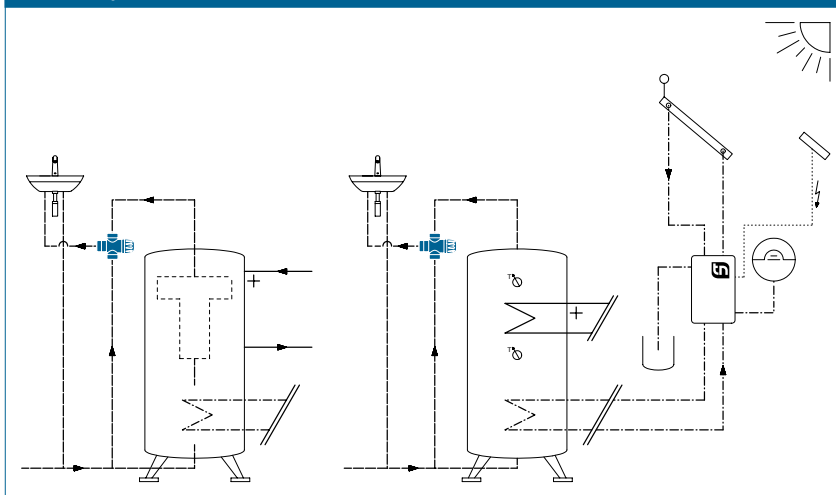

SPECIFICATION TEXT

See www.taconova.com

TECHNICAL DATA

General

- Adjustable temperature ranges:
 - 20 – 50 °C
 - 45 – 65 °C
 - 35 – 70 °C
- k_{VS} values and dimensions as per the relevant tables
- Operating temperature T_{0max} : 100 °C
- Operating temperature T_{0max} with check-valve (CV): 90 °C
- Max. operating pressure P_{0max} : 10 bar
- Min. operating pressure P_{0min} : 0,5 bar
- Working pressure (dynamic): max. 5 bar
- Constant inlet pressure differential: max. 2 bar
- Temperature stability for mixing: max. 3 K (for change in hot water temperature: 15 K)
- Locking function in the event of failure of the cold water supply
- Noise class 2
- Installation position: can be installed in any position

Material

- Housing: brass (resistant to dezincification)
- Internal parts: High-quality plastic
- Seals: EPDM
- Housing with lime resistant-coating

Fluids

- Heating water (VDI 2035; SWKI BT 102-01; ÖNORM H 5195-1)
- Potable water (DIN 1988-200)

Special application

- Diverting function possible (inflow via a mixing gate)
- DN 15 and DN 20 are also suitable for flow water heating units

APPROVALS / CERTIFICATES

- ACS, KTW, W270, TÜV

TYPE OVERVIEW

NovaMix Value 50 FS (Fail Safe) | Thermostatic mixing valve

Temperature range 20 – 50 °C

Order no.	DN	G	Built-in check valve	A	E (l/min)	k_{VS}
253.3002.000	15	¾"	no	76	26	1.6
253.3003.000	20	1"	no	77	36	2.2
253.3004.000	25	1 ¼"	no	77	56	3.4
253.3102.000	15	¾"	yes	76	25	1.5
253.3103.000	20	1"	yes	77	35	2.1
253.3104.000	25	1 ¼"	yes	77	55	3.3

NovaMix Value 65 FS (Fail Safe) | Thermostatic mixing valve

Temperature range 45 – 65 °C (compliant with EN15092)

Order no.	DN	G	Built-in check valve	A	E (l/min)	k_{VS}
253.1002.000	15	¾"	no	76	26	1.6
253.1003.000	20	1"	no	77	36	2.2
253.1004.000	25	1 ¼"	no	77	56	3.4
253.1102.000	15	¾"	yes	76	25	1.5
253.1103.000	20	1"	yes	77	35	2.1
253.1104.000	25	1 ¼"	yes	77	55	3.3

NovaMix Value 70 FS (Fail Safe) | Thermostatic mixing valve

Temperature range 35 – 70 °C (75 °C for Legionella flushing)

Order no.	DN	G	Built-in check valve	A	E (l/min)	k_{VS}
253.2002.000	15	¾"	no	76	26	1.6
253.2003.000	20	1"	no	77	36	2.2
253.2004.000	25	1 ¼"	no	77	56	3.4
253.2102.000	15	¾"	yes	76	25	1.5
253.2103.000	20	1"	yes	77	35	2.1
253.2104.000	25	1 ¼"	yes	77	55	3.3

A = Housing without check valves

E = Extracted (outlet) quantity at $\Delta p = 1,0$ bar

No additional seals required when using the check valves

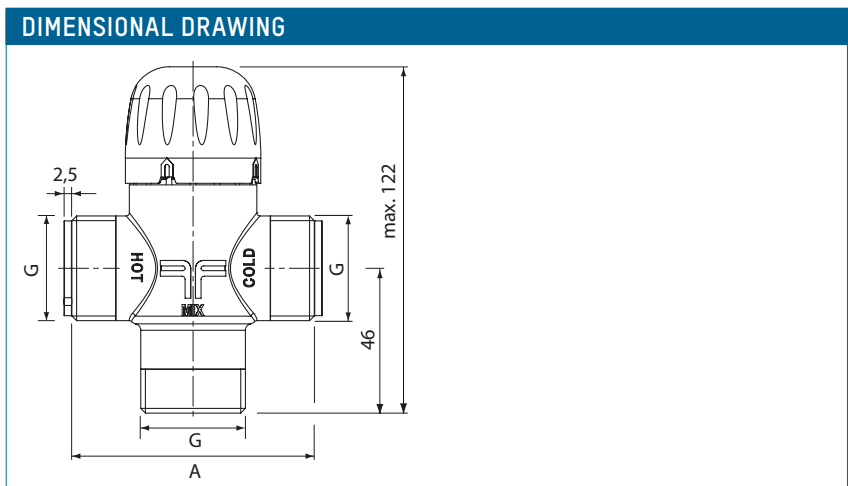

NOTE

The brochure „NOVAMIX ONE RANGE - NEW APPLICATIONS“ contains additional information on the various applications of Taconova mixing valves.

PRESSURE LOSS DIAGRAM

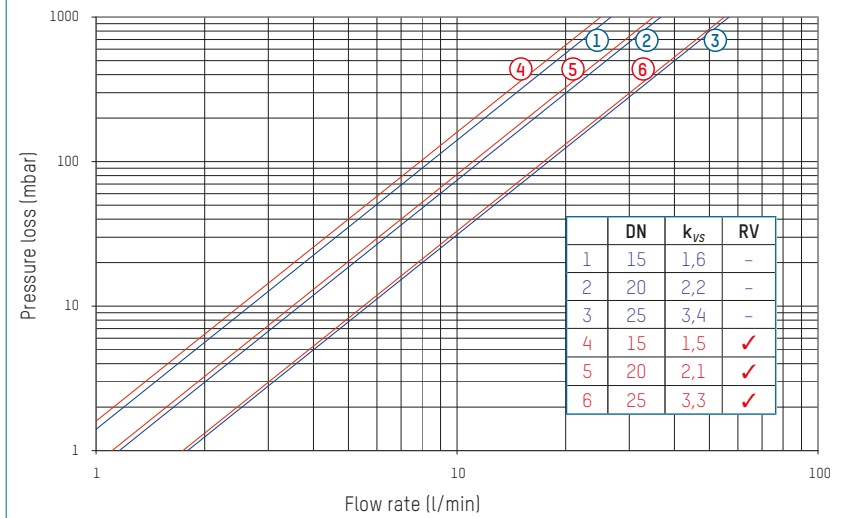

ACCESSORIES



INSULATION BOX

Order no.	DN
296.2329.000	15
296.2330.000	20
296.2331.000	25



CONNECTION SET FOR THREADED PIPE

Order no.	DN	G x R
210.6630.004	15	3/4" x 1/2"
210.6631.004	20	1" x 1/2"
210.6632.004	20	1" x 3/4"
210.6633.004	25	1 1/4" x 1"



CHECK VALVE

Order no.	DN	G
296.5210.003	15	3/4"
296.5211.003	20	1"
296.5212.003	25	1 1/4"

SPARE PARTS



REGULATING PISTON WITH THERMOSTATIC ELEMENT

Order no.	Control range
298.5280.000	for all versions



CAP AND SPINDEL

Order no.	Control range	G
298.5281.000	45 - 65 °C	3/4"
298.5282.000	45 - 65 °C	1"
298.5283.000	45 - 65 °C	1 1/4"
298.5284.000	35 - 70 °C	3/4" + 1"
298.5285.000	35 - 70 °C	1 1/4"

NOVAMIX STANDARD

THERMOSTATIC MIXING VALVE



ADVANTAGES

- Constant temperature of the water at the outlet
- Automatic mixing function without the need for auxiliary power
- Infinite regulation of the nominal temperature in 2 ranges: 20 – 40 °C / 30 – 70 °C
- Protection against scalding; the NovaMix Standard 70 FS model closes tightly
- Special design with anti-scalding device
- Can be used in panel heating systems and for loading storage tanks by means of solid-fuel boilers

Maintaining constant mixing temperatures and limiting temperatures in hot water systems

DESCRIPTION

The automatic thermostatic mixing valve NovaMix Standard ensures a constant temperature of the mixed water at the outlet when used as the central mixing device.

The NovaMix Standard is mainly used in sanitary applications as a regulating device for reducing the temperature of the water coming out of hot water storage tanks. It can also be used in numerous other applications requiring a constant mixing temperature, For example as a mixing unit for constant water mixing temperatures in panel heating systems and for loading storage tanks by means of solid-fuel boilers.

INSTALLATION POSITION

Any.

OPERATION

Standard design:

A thermostatic cartridge and a return spring ensure the constant blend temperature at the outlet. Thanks to the design of the mixing valve, the thermostatic cartridge can be easily replaced in the installed valve if the performance decreases, which occurs due to normal wear and tear.

Special design NovaMix Standard 70 / 40 FS (Fail Safe):

In the case of cold water failure, the hot water supply shuts off automatically and hermetically.

BUILDING CATEGORIES

For pipe installations in drinking water and heating area:

- Apartment blocks, housing estates, multiple dwelling units
- Residential care facilities, hospitals
- Administration and service buildings
- Hotels and restaurants, industrial kitchens
- School buildings and sports facilities
- Commercial and industrial buildings

SYSTEM/BASIC DIAGRAM

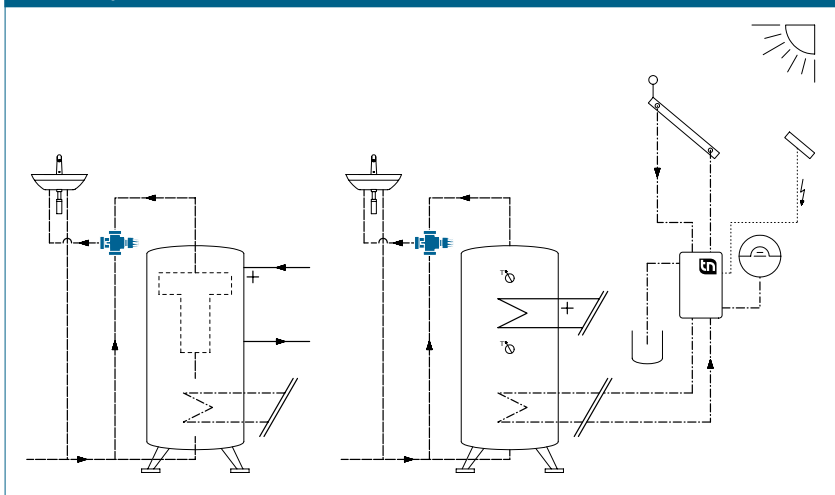

SPECIFICATION TEXT

See www.taconova.com

TECHNICAL DATA

General

- Operating temperature $T_{0\max}$: adjustable temperature ranges, k_{VS} values and dimensions as per the relevant tables
- Operating temperature $T_{0\max}$ with check-valve (CV): 90 °C
- Max. operating pressure $P_{0\max}$: 10 bar
- Min. operating pressure $P_{0\min}$: 0,5 bar
- Working pressure (dynamic): max. 5 bar
- Constant inlet pressure differential: max. 2 bar
- Temperature stability for mixing: max. 3 K (for change in hot water temperature: 15 K)
- Locking function in the event of failure of the cold water supply
- Noise class 2
- Installation position: can be installed in any position

Material

- Housing and inner parts: brass (resistant to dezincification)
- Seals: EPDM
- Housing with lime resistant-coating

Fluids

- Heating water (VDI 2035; SWKI BT 102-01; ÖNORM H 5195-1)
- Potable water (DIN 1988-200)

Special application

- Diverting function possible (inflow via a mixing gate)

APPROVALS / CERTIFICATES

- ACS, KTW, W270

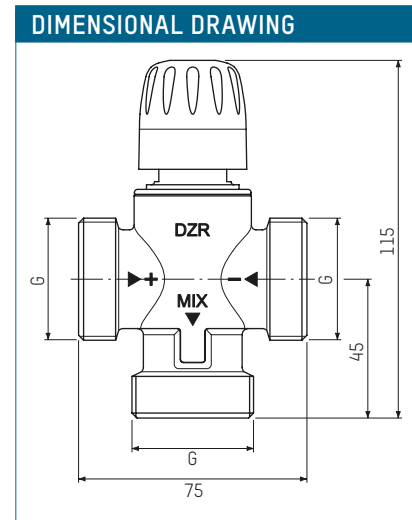

TYPE OVERVIEW

NovaMix Standard 70 / 40 | Thermostatic mixing valve for storage water heating unit

Order no.	DN	G	Control range	$T_{0\max}$	V (l/min)	k_{VS}^1	k_{VS}^2
252.6003.104	20	1"	30 – 70 °C	100 °C	39	1,9	1,65
252.6003.330*	20	1"	30 – 70 °C	100 °C	39	1,9	1,65
252.6004.104	25	1 ¼"	30 – 70 °C	100 °C	53	2,6	2,25
252.6023.104**	20	1"	20 – 40 °C	80 °C	39	1,9	1,65
252.6024.104**	25	1 ¼"	20 – 40 °C	80 °C	53	2,6	2,25

* With integrated check valve

** On request (successor versions see NovaMix Value 20 - 50 °C)

NovaMix Standard 70 FR (Fast Response) | Thermostatic mixing valve for continuous flow water heating

Order no.	DN	G	Control range	$T_{0\max}$	V (l/min)	k_{VS}^1	k_{VS}^2
252.6043.104	20	1"	30 – 70 °C	100 °C	22	1,1	0,7

NovaMix Standard 70 FS (Fail Safe) | Thermostatic mixing valve | Special design with anti-scalding protection in the event of failure of the cold water supply for storage water heating units

Order no.	DN	G	Control range	$T_{0\max}$	V (l/min)	k_{VS}^1	k_{VS}^2
252.6003.107	20	1"	30 – 70 °C	100 °C	39	1,9	1,65
252.6004.107	25	1 ¼"	30 – 70 °C	100 °C	53	2,6	2,25

V = Volume obtained at $\Delta p = 1,5$ bar

k_{VS}^1 = without check-valve

k_{VS}^2 = with check-valve

NOTE

The brochure „NOVAMIX ONE RANGE - NEW APPLICATIONS“ contains additional information on the various applications of Taconova mixing valves.

PRESSURE LOSS DIAGRAM

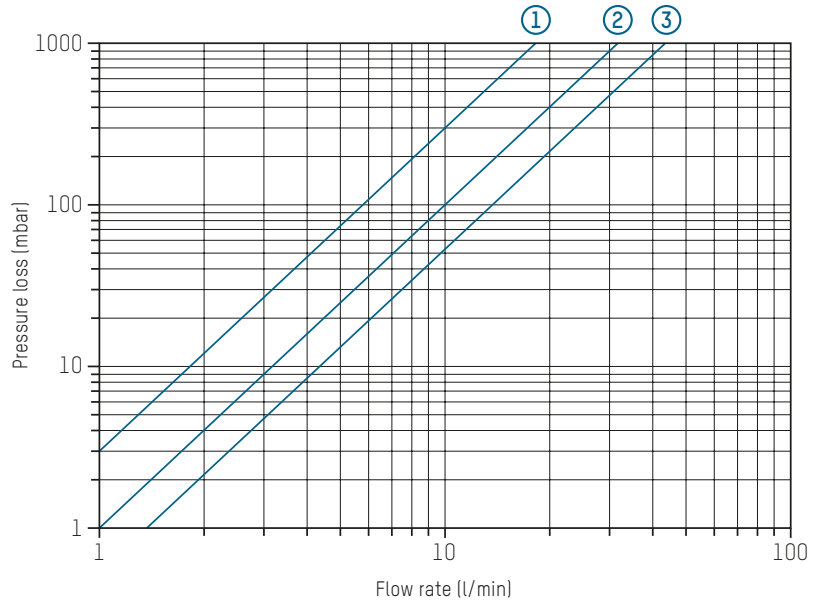

- 1 252.6043.104
- 2 252.6003.104 | 252.6023.104 | 252.6003.107
- 3 252.6004.104 | 252.6024.104 | 252.6004.107

ACCESSORIES



INSULATION BOX

Order no.	DN
296.2326.000	20
296.2327.000	25



CHECK-VALVE

Operating temperature $T_{0,max}$: 95 °C, operating pressure $P_{0,max}$: 10 bar
For insertion in the screw connection at the cold and hot water inlets.

Order no.	Fits to order no.
296.5203.003	252.6003.XXX 252.6023.104 252.6043.104
296.5204.003	252.6004.XXX 252.6024.104

SCREW CONNECTIONS

You will find various suitable screw connections in our „Range of Products“ catalog and our „Price List“.

SPARE PARTS



THERMAL ELEMENT WITH REGULATING PISTON

Order no.	Description
298.5263.000	20 – 40 °C for NovaMix Standard 40
298.5262.000	30 – 70 °C for NovaMix Standard 70/70 FR
298.5264.109	30 – 70 °C for NovaMix Standard 70 FS

NOVAMIX HIGH CAPACITY

THERMOSTATIC MIXING VALVE



ADVANTAGES

- Constant temperature of the water at the outlet
- Automatic mixing function without the need for auxiliary power
- Infinite regulation of the mixed water temperature in the range from 20 – 70 °C
- Protection against scalding; the NovaMix High Capacity model closes tightly
- Special design with anti-scalding device
- Can be used in panel heating systems and for loading storage tanks by means of solid-fuel boilers

Maintaining constant mix temperatures and limiting temperatures in hot water systems

DESCRIPTION

The automatic thermostatic mixing valve NovaMix High Capacity ensures a constant temperature of the mixed water at the outlet when used as the central mixing device. This prevents scalding at the outlet, even with high storage tank temperatures. The large valve cross sections in the NovaMix High Capacity reduce the valve's intrinsic pressure loss (high k_{vs}), permitting high flow rates even at peak times. Special valve seals on the controller piston reduce unwanted mixtures to a minimum (very low internal cold water leakage rate), which provides maximum utilization of the storage temperature.

The NovaMix High Capacity is mainly used in sanitary applications (SVGW approval) as a regulating device for reducing the temperature of the water coming out of hot water tanks. It can also be used in numerous other applications requiring a constant mixing temperature. For example as a mixing unit for constant water mixing temperatures in panel heating systems and for loading storage tanks by means of solid-fuel boilers.

INSTALLATION POSITION

Any.

OPERATION

The mixing valve is supplied with hot water from the storage tank and cold water from the mains network. The temperature of the mixed water is detected by the thermostatic expansion element. If the mixed water temperature diverges from the target value, the thermostatic expansion element moves the regulator piston, thus regulating the hot and cold water intake quantity accordingly, until the mixed water temperature corresponds to the target value.

BUILDING CATEGORIES

For pipe installations in drinking water and heating area:

- Apartment blocks, housing estates, multiple dwelling units
- Residential care facilities, hospitals
- Administration and service buildings
- Hotels and restaurants, industrial kitchens
- School buildings and sports facilities
- Commercial and industrial buildings

SYSTEM/BASIC DIAGRAM

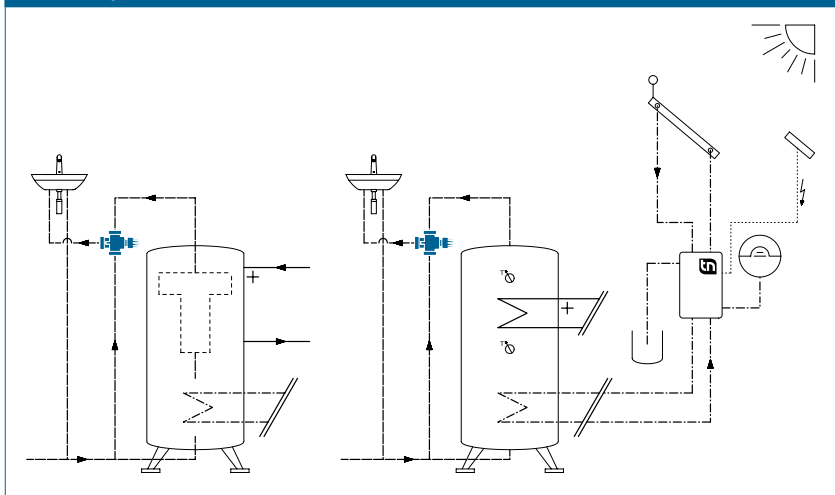

SPECIFICATION TEXT

See www.taconova.com

TECHNICAL DATA

General

- Adjustable temperature range: 20 – 70 °C
- k_{VS} values and dimensions as per the relevant tables
- Operating temperature $T_{0,max}$: 90 °C
- Max. operating pressure $P_{0,max}$: 10 bar
- Temperature stability for mixing: max. 4 K (for change in hot water temperature: 20 K)
- Locking function in the event of failure of the cold water supply
- Weight: 0.9 kg
- Recommended minimum tap flow rate: 5 l/min
- Male thread G (cylindrical) to ISO 228
- Noise class 2
- Installation position: can be installed in any position

Material

- Housing and inner parts: brass (resistant to dezincification)
- Seals: EPDM, NBR
- Housing with lime resistant-coating

Fluids

- Heating water (VDI 2035; SWKI BT 102-01; ÖNORM H 5195-1)
- Potable water (DIN 1988-200)

Special application

- Diverting function possible (inflow via a mixing gate)

APPROVALS / CERTIFICATES

- ACS, KTW, W270

TYPE OVERVIEW

NovaMix High Capacity | Thermostatic mixing valve for storage water heating unit, temperature range 20 – 70 °C

Order no.	DN	G	E (l/min)	k_{VS} 1	k_{VS} 2
252.6034.107	25	1 1/4"	102	6,1	5,9

E = Extracted (outlet) quantity at $\Delta p = 1,0$ bar

k_{VS} 1 = without check valve

k_{VS} 2 = with check valve

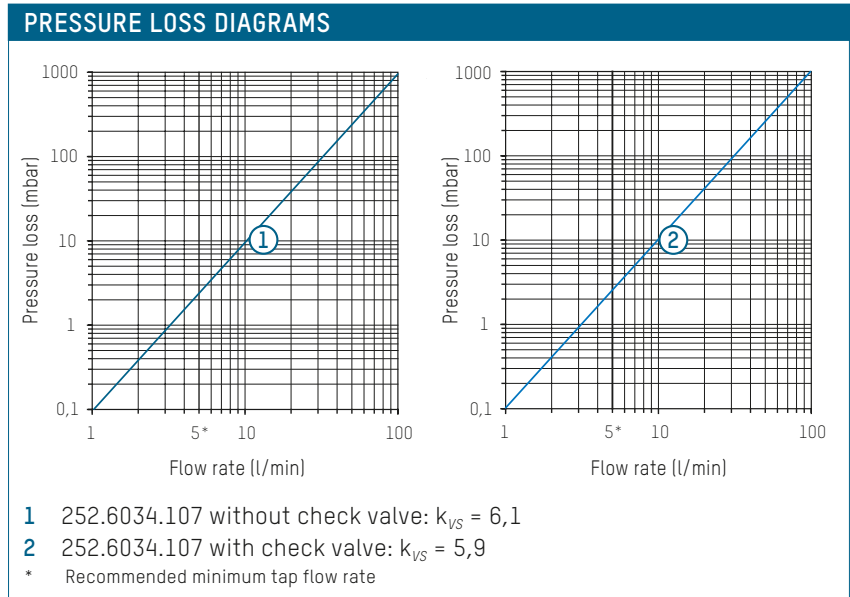
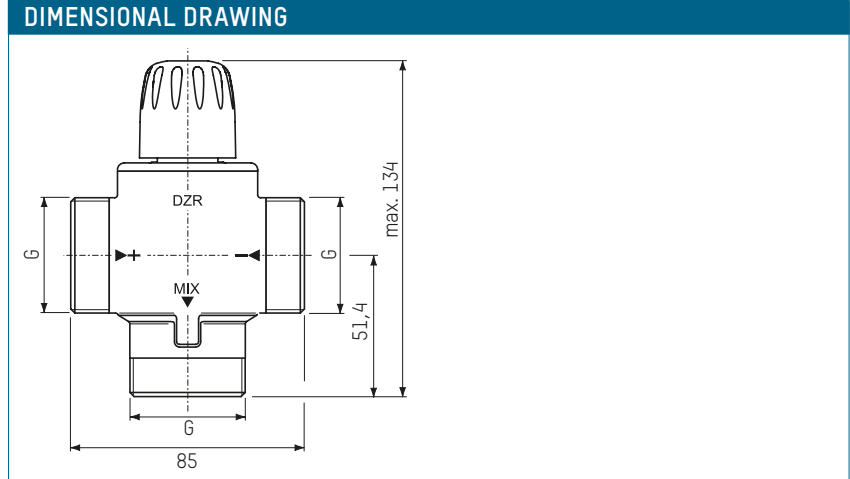

NOTE
The brochure „NOVAMIX ONE RANGE - NEW APPLICATIONS“ contains additional information on the various applications of Taconova mixing valves.

ACCESSORIES



INSULATION BOX

Order no.	DN
296.2328.000	25



CONNECTION SET FOR THREADED PIPE

Order no.	DN	G x R
210.6633.000	25	1 1/4" x 1"



CONNECTION SET FOR THREADED PIPE WITH CHECK VALVE

Order no.	DN	G x R
296.5205.003	25	1 1/4" x 1"

SPARE PARTS



REGULATING PISTON WITH THERMOSTATIC ELEMENT

Order no.
298.5268.000

NOVAMIX COMPACT 70

THERMOSTATIC MIXING VALVE



ADVANTAGES

- Constant temperature of the water at the outlet
- Automatic mixing function without the need for auxiliary power and infinite regulation of the mixed water temperature
- Protection against scalding
- Valve housing with non-stick coating to protect against lime scale deposits
- Check-valves built into cold and hot water connections

Maintaining constant mix temperatures and limiting temperatures in hot water systems

DESCRIPTION

The automatic thermostatic mixing valve NovaMix Compact 70 ensures a constant temperature of the mixed water at the outlet when used as the central mixing device. This prevents scalding at the outlet, even with high storage tank temperatures.

The mixing valve can be used in sanitary applications in both public and private areas. Due to its attractive design, it is also suitable for visible installation directly beneath the wash-basin.

Temperature can be regulated up to 70°C, thermal disinfection can be carried out.

Backflow preventers are already installed ensuring optimum hydraulic functionality.

INSTALLATION POSITION

Any.

OPERATION

A thermostatic cartridge and a return spring ensure the constant blend temperature at the outlet.

Thanks to the design of the mixing valve, the thermostatic cartridge can be easily replaced in the installed valve if the performance decreases, which occurs due to normal wear and tear.

In case of cold water failure, the hot water supply shuts off automatically and hermetically. This ensures full protection against scalding.

BUILDING CATEGORIES

For pipe installations in drinking water and heating area:

- Apartment blocks, housing estates, multiple dwelling units
- Residential care facilities, hospitals
- Administration and service buildings
- Hotels and restaurants, industrial kitchens
- School buildings and sports facilities
- Commercial and industrial buildings

SYSTEM/BASIC DIAGRAM

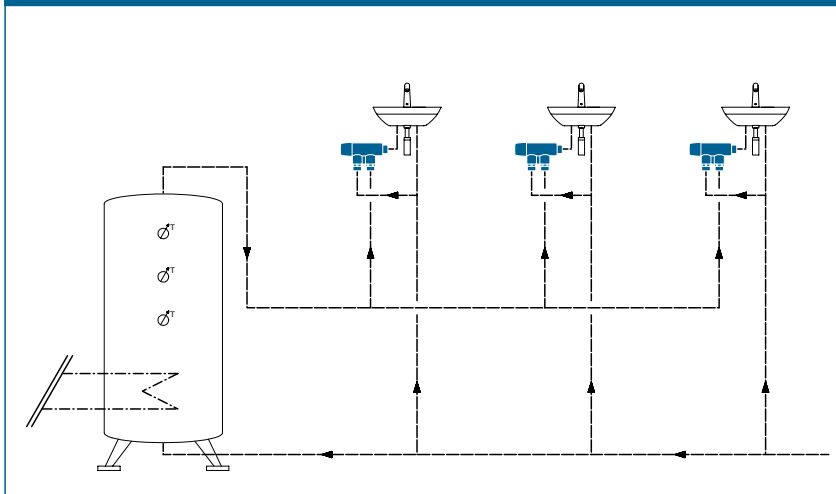

SPECIFICATION TEXT

See www.taconova.com

TECHNICAL DATA

General

- Adjustable temperature range: 30 – 70 °C
- k_{VS} values and dimensions as per the relevant tables
- Operating temperature $T_{0,max}$: 90 °C
- Max. operating pressure $P_{0,max}$: 10 bar
- Min. operating pressure $P_{0,min}$: 0,5 bar
- Temperature stability for mixing: max. 3 K (for change in hot water temperature: 15 K)
- Locking function in the event of failure of the cold water supply
- Noise class 2
- Installation position: can be installed in any position

Material

- Housing: brass (DZR), nickel-plated
- Internal parts: Stainless steel, brass, high-quality plastic
- Seals: EPDM
- Housing with lime resistant-coating

Fluids

- Heating water (VDI 2035; SWKI BT 102-01; ÖNORM H 5195-1)
- Potable water (DIN 1988-200)

APPROVALS / CERTIFICATES

- ACS, KTW, W270

NOTE

The brochure „NOVAMIX ONE RANGE - NEW APPLICATIONS“ contains additional information on the various applications of Taconova mixing valves.

TYPE OVERVIEW

NovaMix Compact 70 | Thermostatic mixing valve
Temperature range 30 – 70 °C

Order no.	DN	G	E (l/min)	k_{VS}
252.6072.104	15	½"	25	1,2

E = Extracted (outlet) quantity at $\Delta p = 1,5$ bar

DIMENSIONAL DRAWING

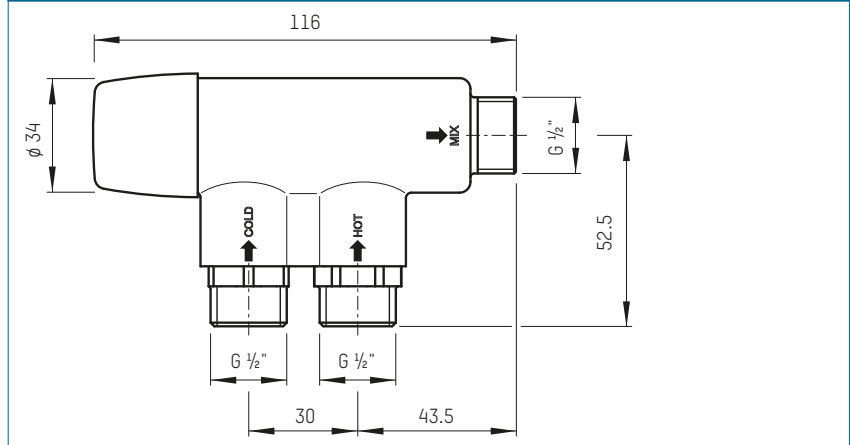

PRESSURE LOSS DIAGRAM

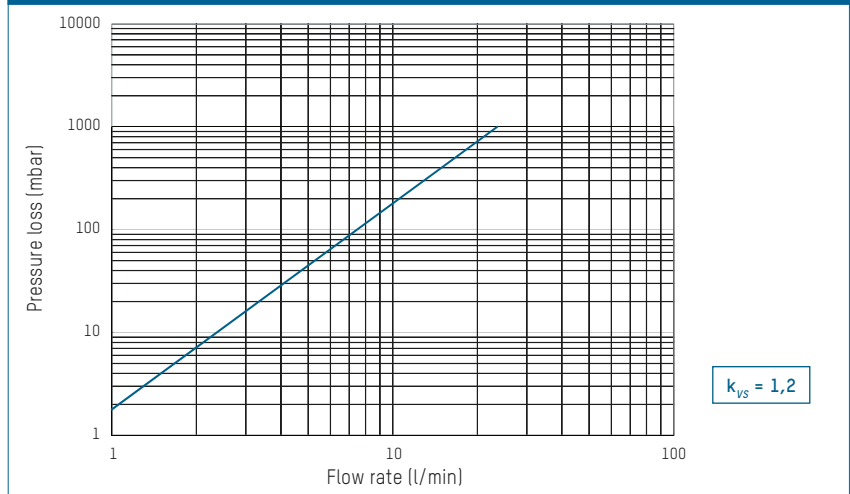

ACCESSORIES



ADAPTER FOR FLAT SEALING FITTINGS

Order no.

296.5223.004

CONNECTIONS

Compression fitting joint with nut, clamping ring and supporting sleeve

Order no.	G × mm	Version for
210.3222.000	½" × 10	Copper pipe 10/1
210.3223.000	½" × 12	Copper pipe 12/1
210.3225.000	½" × 15	Copper pipe 15/1

NOVAMIX COMPACT 50 TMV2

THERMOSTATIC MIXING VALVE



ADVANTAGES

- Constant temperature of the water at the outlet
- Automatic mixing function without auxiliary power
- Infinite regulation of the mixed water temperature in the range from 30 – 70 °C
- Anti-scalding device
- Pipes and draw-off fittings are protected against calcification and corrosion
- Non-stick coating on valve housing to prevent scale build-up
- No maintenance
- Back-flow preventers (check-valves) built into cold and hot water connections
- Build-Cert, TMV-2, ACS approval for potable water

Limits and maintains constant levels of mixing temperatures in systems.

DESCRIPTION

The autonomous thermostatic mixing valve NovaMix Compact 50 ensures a constant mixed water temperature at the outlet. This gives permanent protection against scalding, even with high storage tank temperatures. The mixing valve can be used in sanitary applications in both public and private areas. Due to its attractive design, it is also suitable for visible installation directly beneath the wash-basin. Temperature can be regulated up to 50 °C, thermal disinfection can be carried out.

Backflow preventers are already installed ensuring optimum hydraulic functionality.

INSTALLATION POSITION

Any.

OPERATION

A thermostatic cartridge and a return spring ensure the constant blend temperature at the outlet. Thanks to the design of the mixing valve, the thermostatic cartridge can be easily replaced in the installed valve if the performance decreases, which occurs due to normal wear and tear.

In case of cold water failure, the hot water supply shuts off automatically and hermetically. This ensures full protection against scalding.

BUILDING CATEGORIES

For pipe installations in drinking water and heating area:

- Apartment blocks, housing estates, multiple dwelling units
- Residential care facilities, hospitals
- Administration and service buildings
- Hotels and restaurants, industrial kitchens
- School buildings and sports facilities
- Commercial and industrial buildings

SYSTEM/BASIC DIAGRAM

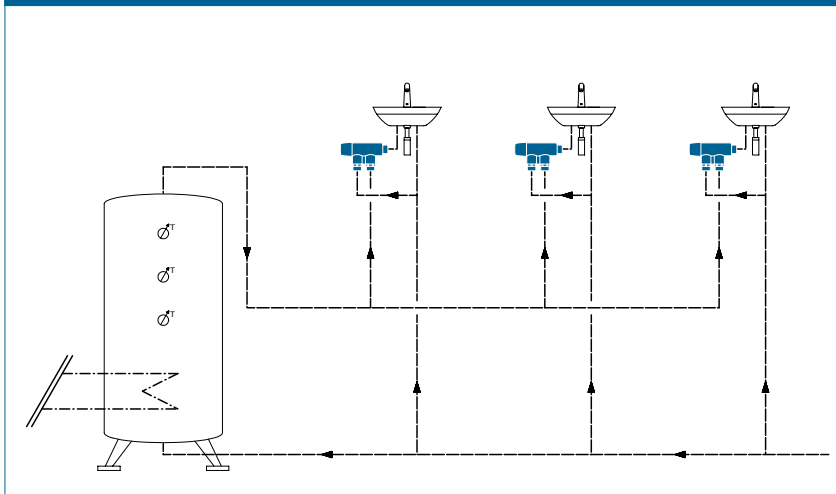

SPECIFICATION TEXT

See www.taconova.com

TECHNICAL DATA

General

- k_{VS} values and dimensions as per the relevant tables
- Max. operating temperature $T_{0\max}$: 90 °C
- Max. operating pressure $P_{0\max}$: 10 bar
- Min. operating pressure $P_{B\min}$: 0,5 bar
- Adjustable temp. range: 30 – 50 °C
- Mix temperature stability: max. 3 K (for hot water temp. change 15 K)
- Shut-off function in event of cold water failure
- Noise class 2
- Installation position: any

Material

- Housing: brass (DZR), nickel-plated
- Internal parts: Stainless steel, brass, high-quality plastic
- Seals: EPDM
- Housing with anti-lime scale coating

Flow media

- Heating water (VDI 2035; SWKI BT 102-01; ÖNORM H 5195-1)
- Potable water (DIN 1988-200)

APPROVALS

- Build-Cert, TMV-2, ACS

NOTE

The brochure „NOVAMIX ONE RANGE - NEW APPLICATIONS“ contains additional information on the various applications of Taconova mixing valves.

TYPE PROGRAM

NovaMix Compact 50 TMV2 | Thermostatic mixing valve
Temperature range 30 – 70 °C

Item no.	DN	G	E (l/min)	k_{VS}
252.6073.107	15	½"	23,7	1,42

E = Extracted outlet quantity at $\Delta p = 1$ bar

DIMENSIONAL DRAWING

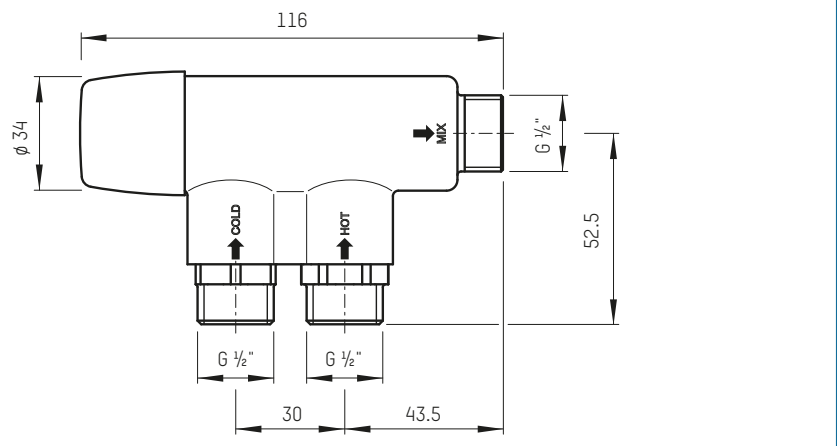

PRESSURE LOSS DIAGRAM

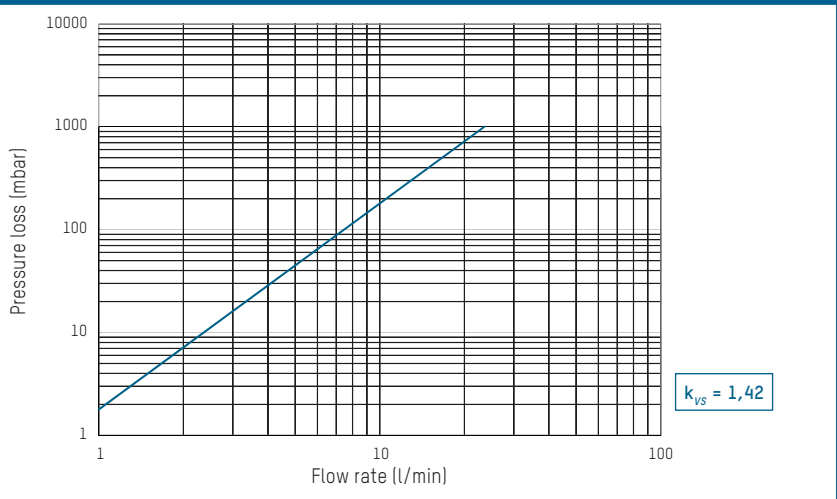

ACCESSORIES



ADAPTER FOR FLAT SEALING FITTINGS

Item no.
296.5223.004

CONNECTIONS

Compression fitting joint with nut, clamping ring and supporting sleeve

Item no.	G × mm	Version for
210.3222.000	½" × 10	Copper pipe 10/1
210.3223.000	½" × 12	Copper pipe 12/1
210.3225.000	½" × 15	Copper pipe 15/1

SWITCHING WITH AN AUTOMATIC DRIVE

Motorized valves control the direction of flow of the medium by opening or closing the valve.

VERSATILE APPLICATIONS FOR RENEWABLE ENERGIES

The integration of renewable energies in the heating systems and the energy-efficient operation of heat generators, heat distributors, air conditioning and drinking water heaters pose major challenges to installation technology. Heating systems with multiple heat generators or that integrate renewable energies are becoming increasingly the norm, but require corresponding hydraulic circuits.

The areas of application of two and three-way motorized valves include, for example: switching the loading of solar storage units

- Storage tank loading in various temperature levels
- Increasing the return for biomass heating boilers
- Switching between storage tanks and heat generators
- Controlling different heat exchangers
- Switching between different storage systems

RAPID SWITCHING

The NovaZone Ball motorized ball valves and NovaZone Valve motorized valves feature short regulating times and a broad area of applications for automatic switching, opening and closing of hydraulic systems.

SWITCHING AND CONTROLLING SYSTEM HYDRAULICS

The opening, closing and switching processes are triggered by the NovaZone Ball motorized ball valves and NovaZone Valve motorized valves by means of a control contact (e.g. a thermostat or switch). The drives of the motorized ball valves are controlled by means of relays and only consume power for the opening and closing processes. On the motorized valve, the return to home position is achieved by means of a return spring (closed when off operating mode). The motorized ball valves in dimensions up to DN 100 offer a broad range of applications and are also approved for drinking water installations. These have an additional benefit for system automation thanks to potential-free auxiliary switches that can be used to output signal messages or control pumps, for example. The motorized ball valves and motorized valves can also be activated manually with a lever, which is supplied as part of the deliverables.

AUTOMATIC CONTROL AND SAFETY WHEN OPERATING THE SYSTEM

NovaZone Ball motorized ball valves and NovaZone Valve motorized valves enable automatic two-way or three-way control in heating, solar energy and cooling systems.

BENEFITS AT THE PLANNING STAGE

- Automatically operated two-way and three-way valves for switching the direction of flow in hydraulic systems
- System automation by means of potential-free auxiliary switches
- Short regulating times
- Power is only consumed for the opening and closing process
- Potential-free auxiliary switches for outputting signals and controlling pumps

BENEFITS AT THE INSTALLATION STAGE

- Automatically operated two-way and three-way valves for switching the direction of flow in hydraulic systems
- System automation by means of potential-free auxiliary switches
- Short regulating times
- Power is only consumed for the opening and closing process
- Potential-free auxiliary switches for outputting signals and controlling pumps
- Drinking water quality approval for use in drinking water heating and hot water solar energy systems or for closing drinking water lines by remote control

Zone valves

The NovaZone Ball and NovaZone Valve zone valves supply system components or individual units with the appropriate volume flow or switch them off.

- NovaZone Ball
- NovaZone Valve

APPLICATIONS

Valves and accessories from Taconova can be used in various ways in heating, air conditioning, ventilation and sanitary systems

Heating and cooling energy generation

- Solar thermal energy
- Oil, gas, electricity, biomass
- District heating

Heating and cooling energy distribution (Indoor temperature control)

- Underfloor heating
- Radiators
- Chilled and heated ceilings

NOVAZONE BALL

MOTOR-DRIVEN BALL VALVE



Control of volume flows for different fluids in HVAC systems

DESCRIPTION

Drive with relay for controlling volume flows in HVAC systems. System parts or individual units are supplied with fluid or switched off depending on the switching criterion (open/closed for 2-way valves and switching for 3-way valves). Range of applications for different fluids (water, glycol mixtures).

INSTALLATION POSITION

The motor-driven ball valve can be installed horizontally or vertically (180°).

OPERATION

System parts or individual units are supplied with fluid or switched off depending on the switching criterion. The ball valve is moved from its initial to its final position by means of a 1-pin control contact (thermostat, switch, etc.). Depending on the control contact, the valve rotates forwards or backwards until it reaches its final position. In the case of an open control contact, the relay falls away and causes the direction to be reversed. The ball valve cannot be held in an intermediate position. The motor-driven ball valve can allow flows in both directions.

ADVANTAGES

NovaZone Ball up to 2"

- One potential-free auxiliary switch
- Short actuating times
- Lever for manual operation
- 3-way with inversion of direction of operation
- Valve setting is evident from the motor
- Protection class IP 42
- Low maintenance
- Low noise

NovaZone Ball up to 2 ½"

- Available in sizes up to DN 100 (2-way)
- Two potential-free auxiliary switches
- Two limit switches acting as toggles
- Protection type IP 65
- Low maintenance
- Low noise

BUILDING CATEGORIES

For pipe installations in heating and cooling area:

- Apartment blocks, housing estates, multiple dwelling units
- Residential care facilities and hospitals
- Administration and service buildings
- Hotels and restaurants, industrial kitchens
- School buildings and sports halls / sports facilities
- Commercial and industrial buildings
- Facilities with partial use – for example, barracks, camping sites etc.

SYSTEM/BASIC DIAGRAM

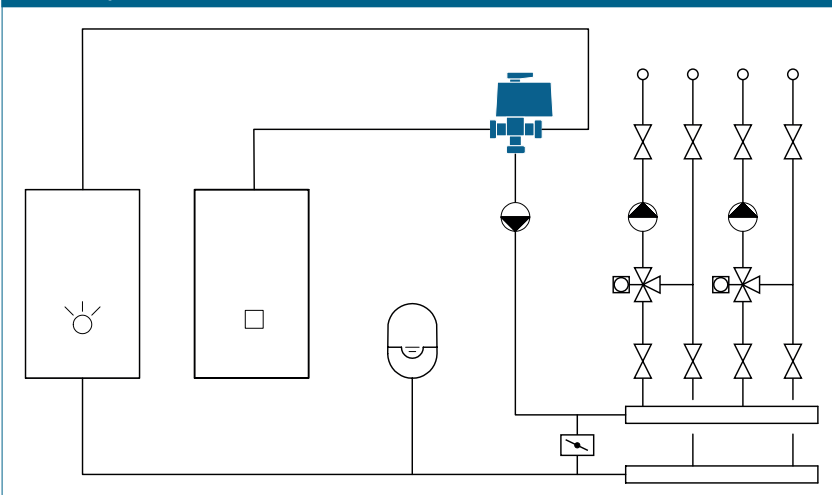

TYPE OVERVIEW
NovaZone Ball 2way | 2-way motor-driven valve with relay, open/closed function

Order no. 230 V	DN	Rp	K _{vs}	Weight (kg)	Protection standard	Duration	Auxiliary switch
256.2172.999	15	½"	30.0	1,330	IP 42	45 Sec	1 potential-free
256.2173.999	20	¾"	55.6	1,450	IP 42	45 Sec	1 potential-free
256.2174.999	25	1"	85.0	1,630	IP 42	45 Sec	1 potential-free
256.2175.999	32	1¼"	120.5	1,875	IP 42	45 Sec	1 potential-free
256.2176.999	40	1½"	240.0	2,230	IP 42	45 Sec	1 potential-free
256.2177.999	50	2"	360.0	2,845	IP 42	45 Sec	1 potential-free
256.2178.999	65	2½"	410.0	6,480	IP 65	60 Sec	2 potential-free
256.2179.999 *	80	3"	470.0	8,070	IP 65	60 Sec	2 potential-free
256.2180.999 *	100	4"	866.0	10,500	IP 65	60 Sec	2 potential-free

Order no. 24 V**	DN	Rp	K _{vs}	Weight (kg)	Protection standard	Duration	Auxiliary switch
256.2072.999 **	15	½"	30.0	1,330	IP 42	45 Sec	1 potential-free
256.2073.999 **	20	¾"	55.6	1,450	IP 42	45 Sec	1 potential-free
256.2074.999 **	25	1"	85.0	1,630	IP 42	45 Sec	1 potential-free
256.2075.999 **	32	1¼"	120.5	1,875	IP 42	45 Sec	1 potential-free
256.2076.999 **	40	1½"	240.0	2,230	IP 42	45 Sec	1 potential-free
256.2077.999 **	50	2"	360.0	2,845	IP 42	45 Sec	1 potential-free

NovaZone Ball 3way | 3-way motor-driven valve with relay, switching function

Order no. 230 V	DN	Rp	K _{vs}	Weight (kg)	Protection standard	Duration	Auxiliary switch
256.3172.999	15	½"	6.5	1,400	IP 42	90 Sec	1 potential-free
256.3173.999	20	¾"	10.5	1,510	IP 42	90 Sec	1 potential-free
256.3174.999	25	1"	16.5	1,680	IP 42	90 Sec	1 potential-free
256.3175.999	32	1¼"	27.2	2,300	IP 42	90 Sec	1 potential-free
256.3176.999	40	1½"	47.3	2,800	IP 42	90 Sec	1 potential-free
256.3177.999	50	2"	73.0	4,000	IP 42	90 Sec	1 potential-free
256.3178.999 *	80	3"	177.5	10,400	IP 65	120 Sec	2 potential-free

Order no. 24 V**	DN	Rp	K _{vs}	Weight (kg)	Protection standard	Duration	Auxiliary switch
256.3072.999	15	½"	6.5	1,400	IP 42	90 Sec	1 potential-free
256.3073.999 *	20	¾"	10.5	1,510	IP 42	90 Sec	1 potential-free
256.3074.999	25	1"	16.5	1,680	IP 42	90 Sec	1 potential-free
256.3075.999	32	1¼"	27.2	2,300	IP 42	90 Sec	1 potential-free
256.3076.999 *	40	1½"	47.3	2,800	IP 42	90 Sec	1 potential-free
256.3077.999	50	2"	73.0	4,000	IP 42	90 Sec	1 potential-free

Silicone-free model available on request

* 8-week delivery time

** While stocks last; thereafter, please order ball valve and drive (298.X...) separately (see pricelist)

SPECIFICATION TEXT

See www.taconova.com

TECHNICAL DATA

General

Drive

- Operating voltage
 - 230 V ($\pm 10\%$) 50 Hz
 - $\leq 2''$: 24 V (on request)
- Power consumption
 - Motor $\leq 2''$: 4,4 VA
 - Motor $> 2\frac{1}{2}''$: 10,3 VA
 - Relays: 1,75 VA
- Relay controlled
- Protection class I (earthed)
- Protection class of actuator:
 - $\leq 2''$: IP42
 - $\geq 2\frac{1}{2}''$: IP65
- NovaZone Ball 2-way limit switch
 - $> 2\frac{1}{2}''$: Limit switches acting as toggles, not potential-free
- NovaZone Ball 3way limit switch
 - $> 2\frac{1}{2}''$: Limit switches acting as toggles, not potential-free
- Switching current: 5 (2) A
- Angle of rotation limited by limit switches

NovaZone Ball 3-way: both limit switches acting as toggles, with terminal output

- Ambient temperature: -10 – 55 °C

Valve bodies

- Operating temperature $T_{0\max}$: 110 °C
- Operating pressure $P_{0\max}$: 10 bar
- Differential pressure: max. 10 bar
- Temperature of medium: -15 – 110 °C (NovaZone Ball 3way DN 80 to 95 °C)
- Inner thread Rp (cylindrical) under DIN 2999 / ISO 7

Material

- Housing: Brass, nickel-plated
- Ball: Brass, hard-chrome plated
- Seal seat: PTFE
- Seals: EPDM

Fluids

- Heating water (VDI 2035; SWKI BT 102-01; ÖNORM H 5195-1)
- Water and proprietary additives used against corrosion and freezing up to 45%

DIMENSIONAL DRAWING

NovaZone Ball 2way

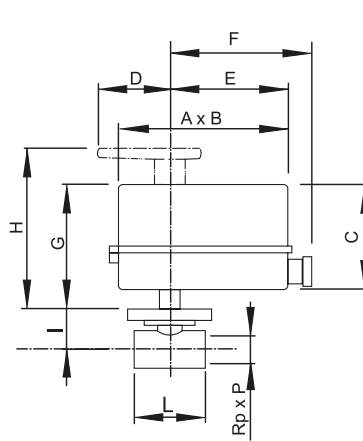

NovaZone Ball 3way

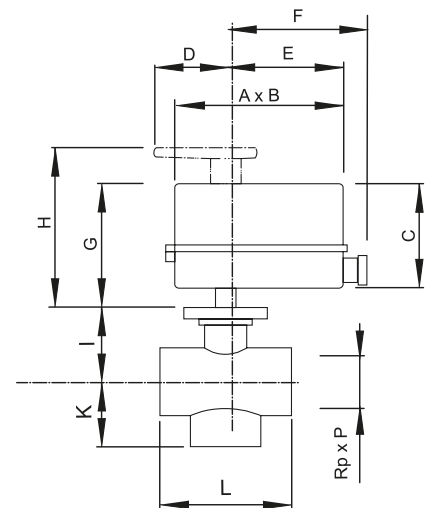

MEASUREMENT TABLE

NovaZone Ball 2way

Order no.	DN	Rp x P	A x B	C	D	E	F	G	H	I	L
256.2172.999	15	1/2" x 14	130 x 73	84	55	90	110	100	129	41	56
256.2173.999	20	3/4" x 16	130 x 73	84	55	90	110	100	129	45	66
256.2174.999	25	1" x 16	130 x 73	84	55	90	110	100	129	49	76
256.2175.999	32	1 1/4" x 18	130 x 73	84	55	90	110	100	129	61	86
256.2176.999	40	1 1/2" x 19	130 x 73	84	55	90	110	100	129	66	97
256.2177.999	50	2" x 20	130 x 73	84	55	90	110	100	129	72	112
256.2178.999	65	2 1/2" x 22	168 x 95	107	-	76	102	145	-	103	141
256.2179.999	80	3" x 25	168 x 95	107	-	76	102	145	-	114.5	159
256.2180.999	100	4" x 28	168 x 95	107	-	76	102	145	-	145	190

NovaZone Ball 3way

Order no.	DN	Rp x P	A x B	C	D	E	F	G	H	I	L	K
256.3172.999	15	1/2" x 14	130 x 73	84	55	90	110	100	129	41	56	30
256.3173.999	20	3/4" x 16	130 x 73	84	55	90	110	100	129	45	66	35
256.3174.999	25	1" x 17	130 x 73	84	55	90	110	100	129	49	76	40
256.3175.999	32	1 1/4" x 23	130 x 73	84	55	90	110	100	129	61	86	54
256.3176.999	40	1 1/2" x 24	130 x 73	84	55	90	110	100	129	66	97	61
256.3177.999	50	2" x 28	130 x 73	84	55	90	110	100	129	72	112	73
256.3178.999	80	3" x 33	168 x 95	107	-	76	102	145	-	145	190	108

NOTES

- Avoid formation of condensation in drive
- With the NovaZone Ball 3way, the volume flow is briefly interrupted when switching

PRESSURE LOSS AND FLOW DIAGRAMS

NovaZone Ball 2way

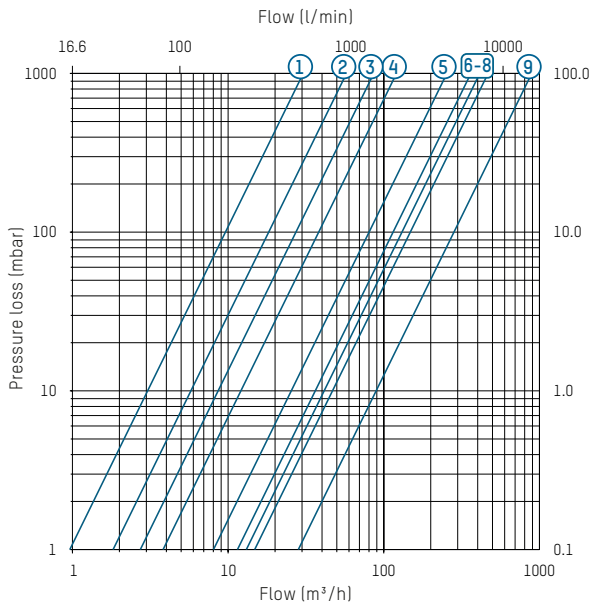

Key

1 256.2172.999	6 256.2177.999
2 256.2173.999	7 256.2178.999
3 256.2174.999	8 256.2179.999
4 256.2175.999	9 256.2180.999
5 256.2176.999	

NovaZone Ball 3way

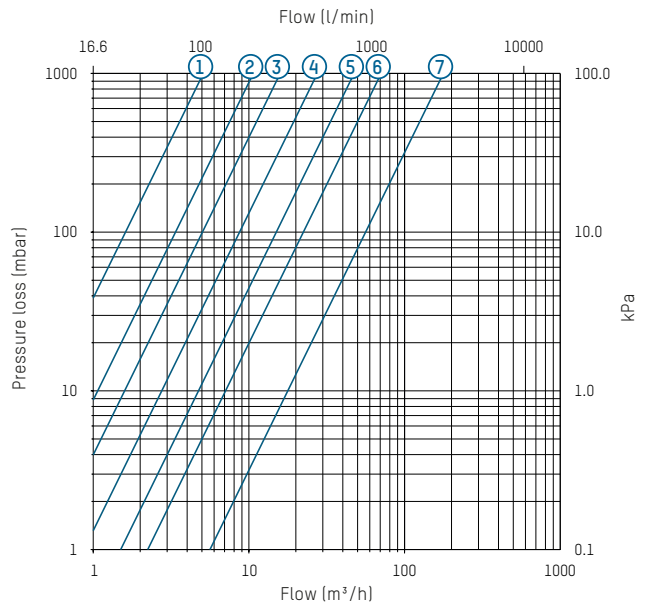

Key

1 256.3172.999	5 256.3176.999
2 256.3173.999	6 256.3177.999
3 256.3174.999	7 256.3178.999
4 256.3175.999	

ANGLE OF ROTATION

NovaZone Ball 2way – Angle of rotation 90°

Position 0°

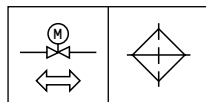

Position 90°

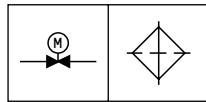

NovaZone Ball 3way – Angle of rotation 180°

Position 0°

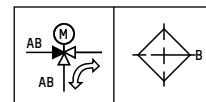

Position 180°

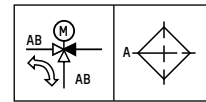

CIRCUIT DIAGRAM

NovaZone Ball 2way

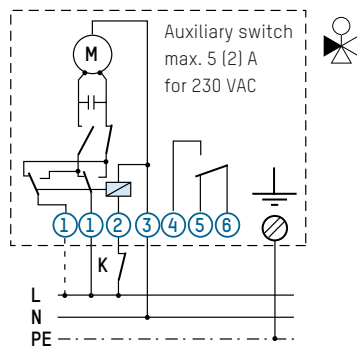
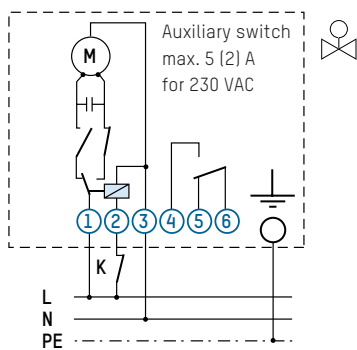

NovaZone Ball 3way

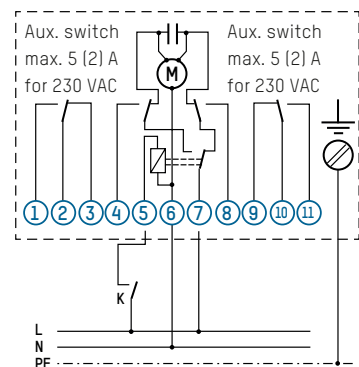



SPARE PARTS



DRIVE FOR BALL VALVE FROM ½" – 2"

Order no.	Fits
298.5625.999	NovaZone Ball 2way
298.5635.999	NovaZone Ball 3way

DRIVE FOR BALL VALVE FROM 2½" – 4"

Order no.	Fits
298.5626.999	NovaZone Ball 2way
298.5636.999	NovaZone Ball 3way

Ball valves on request

NOVAZONE VALVE

ZONE VALVE



Diagram partially similar

ADVANTAGES

- Short actuating times (max. 20 seconds)
- With lever for manual operation
- Low maintenance
- Visible valve setting
- For water, heating water and glycol/water mixtures
- Suitable for solar systems up to 160°C

Control of volume flows for different fluids in HVAC systems

DESCRIPTION

Zone valve with electromotive drive and spring return for control in HVAC systems. System parts or individual units are supplied with fluid or switched off depending on the switching criterion (open/closed for 2-way valves and switching for 3-way valves). With lever for manual operation. The valve setting is visible. Stuffing box seal provided by two successive O-ring seals. Range of applications for different fluids (water, glycol mixtures).

INSTALLATION POSITION

The installation position is variable. Only the arrow indicating the direction of flow of the medium needs to be noted.

OPERATION

The valve body is moved from its initial to its final position by means of a 1-pin control contact (e.g. thermostat, switch, etc.). The valve is returned to its initial position in a currentless state by means of a return spring.

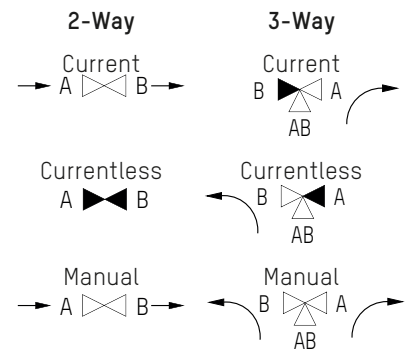

BUILDING CATEGORIES

For pipe installations in heating and cooling area:

- Apartment blocks, housing estates, multiple dwelling units
- Residential care facilities and hospitals
- Administration and service buildings
- Hotels and restaurants, industrial kitchens
- School buildings and sports halls / sports facilities
- Commercial and industrial buildings
- Facilities with partial use, such as barracks, camping sites

SYSTEM/BASIC DIAGRAM

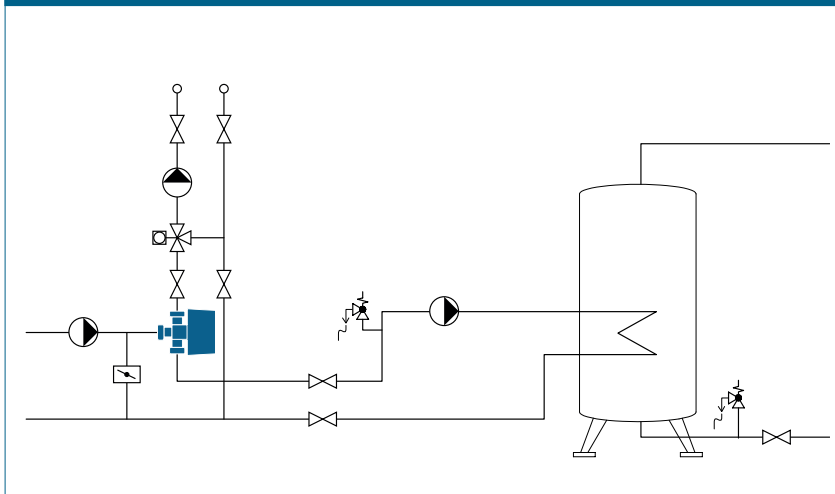

SPECIFICATION TEXT

 See www.taconova.com
TECHNICAL DATA
General

- Operating mode: normally closed
- Ambient temperature: up to 60 °C

Drive

- Ambient temperature: up to 60 °C
- Operating voltage: 230 V (± 10 %) 50 Hz
- Power consumption: 6 W
- Protection type IP 20
- CE conformance

- Cable length 1 m
- Opening times: 12 sec.
- Closing times: 5 sec.

Valve bodies

- Operating temperature $T_{0\max}$: 160 °C
- Operating pressure $P_{0\max}$: 10 bar
- Temperature of medium: -20 – 160 °C
- Shaft seal: stuffing box seal provided by two successive O-ring seals

Material

- Housing: brass
- Paddle: EPDM

Fluids

- Heating water (VDI 2035; SWKI BT 102-01; ÖNORM H 5195-1)
- Water and proprietary additives used against corrosion and freezing up to 50%

TYPE OVERVIEW
NovaZone Valve 2way | 2-way zone valve with electromotive drive and spring return, standard version for medium temperatures of -20 – 160 °C

Function: Open / Closed

Order no.	Voltage	DN	Rp	K_{vs} m ³ /h	Δp max (bar)
256.5242.999S	230 V	15	½"	3600 l/h	1,4
256.5243.999S	230 V	20	¾"	6200 l/h	0,7
256.5244.999S	230 V	25	1"	6200 l/h	0,7

NovaZone Valve 3way | 3-way zone valve with electromotive drive and spring return, standard version for medium temperatures of -20 – 160 °C

Function: Switching

Order no.	Voltage	DN	Rp	K_{vs} m ³ /h	Δp max (bar)
256.5342.999S	230 V	15	½"	4000 l/h	1,4
256.5343.999S	230 V	20	¾"	6400 l/h	0,7
256.5344.999S*	230 V	25	1"	8800 l/h	0,5

 * high k_{vs} value

NOTE

Taconova Group AG maintains these articles under the name XXX.XXXX.999N.

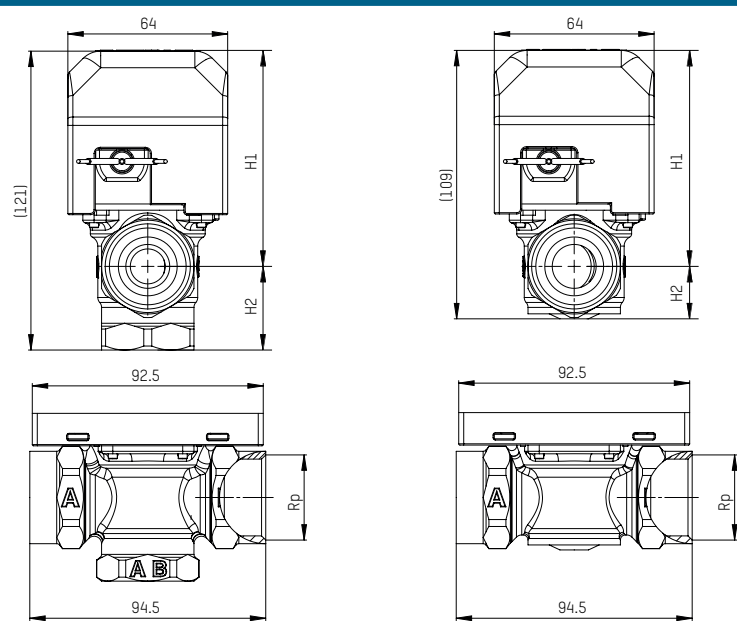
DIMENSIONAL DRAWING

SIZE MEASUREMENT

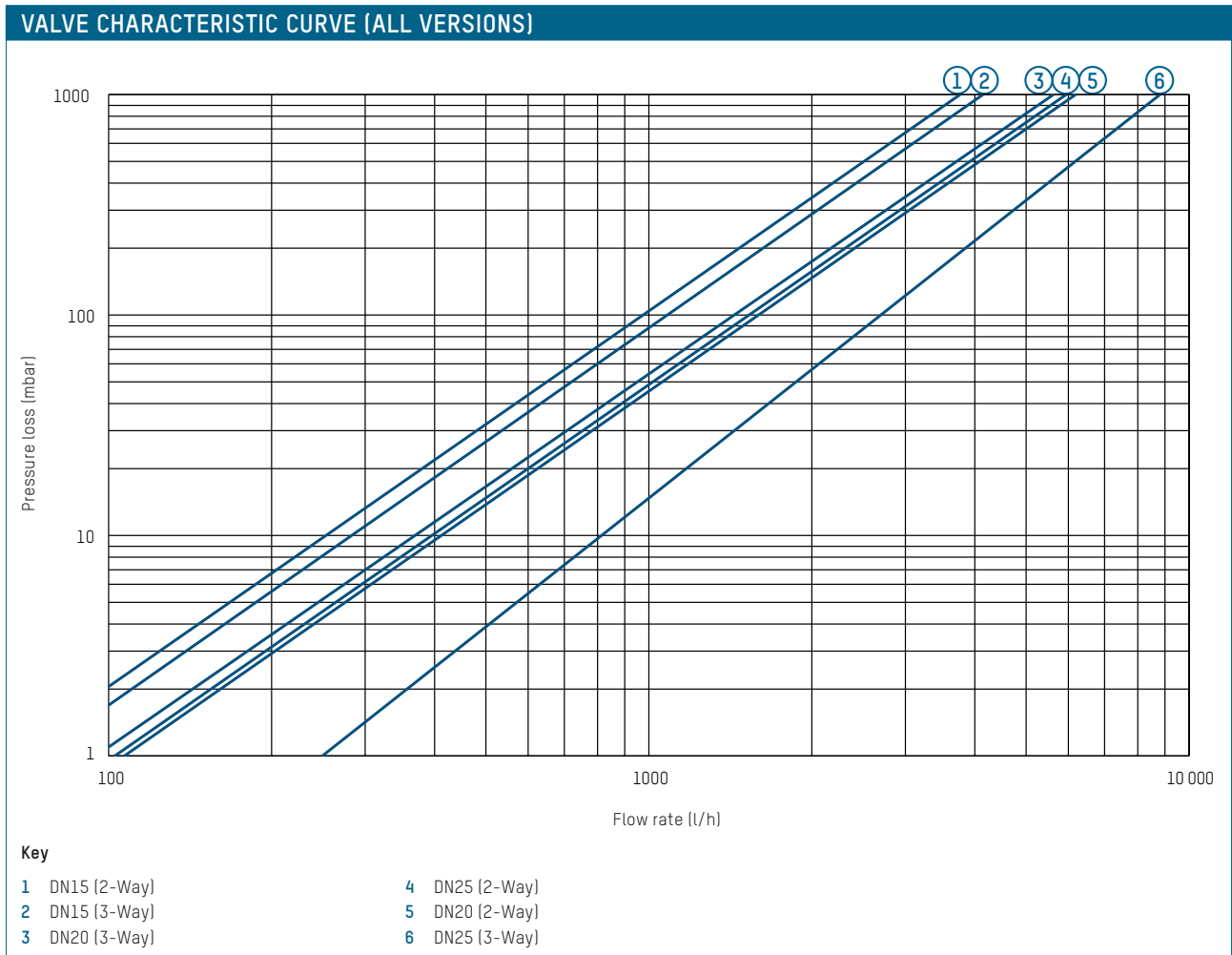
Fits	H	H1	H2
All DN 15 2-way through valves	109	87	22
All DN 20 2-way through valves	109	87	22
All DN 25 2-way through valves	109	87	22
All DN 15 3-way switching valves	121	87	34
All DN 20 3-way switching valves	121	87	34
All DN 25 3-way switching valves	121	87	34



COMBINED VALVE FOR THE BOILER PROVIDES VENTILATION AND PROTECTS AGAINST OVERPRESSURE

Boiler valve groups take over the functions of technical safety equipment on boilers.

SAFETY STANDARD

The safety equipment on boilers includes a safety group for the ventilation, pressure monitoring and pressure display functions. The Tri-Bloc safety group unites four functions in a single valve:

- Continuous and automatic ventilation
- Blowing off overpressure
- Displaying the pressure
- Providing a connection for an expansion vessel or KFE spigot

CONNECTION-READY SAFETY GROUP

The Tri-Block combination valve consists of a brass valve carrier with safety valve (blow-off pressure 2.5 or 3 bar) a TacoVent HyVent rapid ventilator and a manometer with self-sealing screw connector. The Tri-Bloc also has two additional screw connectors for an expansion vessel (R 3/4") and a filling spigot (Rp 1/2").

FLOAT-CONTROLLED VENTILATING VALVE

The TacoVent HyVent ventilating valve has a float on the surface of the water that holds the ventilating bore tightly closed by means of a valve needle. When air collects in the boiler, the float is lowered as the water level drops, opening the air outlet. An integrated automatic closure enables the float-based ventilating valve to be replaced under system pressure.

COMBINATION VALVE FOR EVERY INSTALLATION POSITION

The highlight of the Tri-Bloc safety valve group is the multi-connection system, which permits several different installation positions and therefore helps avoid time-consuming installation work with additional fittings:

Thanks to the rotating screw connector, the safety valve can be turned in the required direction.

The ventilating valve can be connected to the valve body in several different variants, so that this can be installed vertically in any installation position without requiring additional angled components.

The manometer with self-sealing thread can either be fitted on the side or on the front.

COMPACT SAFETY VALVE

The Tri-Bloc boiler safety group unites the required safety valves in a single valve body, saving time during installation.

BENEFITS AT THE PLANNING STAGE

- Combination valve as technical safety equipment for boilers
- Ready-assembled and tested safety fitting for ventilation, pressure monitoring and pressure display with safety valve approved by the TÜV Technical Control Association
- Additional screw connection for expansion vessel and KFE Spigot
- Automatic and permanent ventilation

BENEFITS AT THE INSTALLATION STAGE

- Time-saving installation without additional fittings thanks to multiple connection system
- Flexibility for different installation situations thanks to variable connection options
- Rapid ventilation when filling the system
- Easy control of the system filling pressure
- Float-based ventilating valve can be replaced under system pressure
- Rotating safety valve
- Self-sealing connections

Multi purpose unit	
The extremely compact TriBloc valve is a safety group for heating systems to ventilate, to aerate, and to indicate and relieve pressure.	<ul style="list-style-type: none"> ▪ TriBloc

APPLICATIONS

Valves and accessories from Taconova can be used in various ways in heating, air conditioning, ventilation and sanitary systems:

Heating and cooling energy generation	Heating and cooling energy distribution (Indoor temperature control)	Sanitary systems
<ul style="list-style-type: none"> ▪ Solar thermal energy ▪ Oil, gas, electricity, biomass ▪ District heating 	<ul style="list-style-type: none"> ▪ Underfloor heating ▪ Radiators ▪ Chilled and heated ceilings 	<ul style="list-style-type: none"> ▪ Fresh water

TRIBLOC

SAFETY GROUP



Permanent and automatic venting, aerating as well as pressure relief.

DESCRIPTION

The safety group is a multiple fitting for heating equipment in the performance range up to 50 kW (DIN 4751). The individual components are assembled into one unit and tested. A self-sealing manometer is included (not assembled). The unit also has a connection for an expansion vessel (R 3/4") or, if required, a filling valve (Rp 1/2").

INSTALLATION POSITION

Vertically upwards.

OPERATION

Venting and aerating

A float-controlled valve opens as the volume of air increases and continually releases the air collected in the cap. The junction canal transports the water and air straight to the air cap.

Pressure relief

The safety valve prevents the pressure from rising above the normal operating level by releasing heating water via a membrane.

ADVANTAGES

- Four operations (venting, pressure relief, displaying, connecting) in a space-saving combination
- Self-sealing component connections
- Use of proven components (float air vent, safety valve, manometer)
- Versatile positioning of the manometer (frontal, lateral)
- Manometer with check valve
- Float air vent with automatic check valve

BUILDING CATEGORIES

For pipe installations in heating area:

- Apartment blocks, housing estates, multiple dwelling units
- Residential care facilities, hospitals
- Administration and service buildings
- Hotels and restaurants, industrial kitchens
- School buildings and sports facilities
- Commercial and industrial buildings

SYSTEM/BASIC DIAGRAM

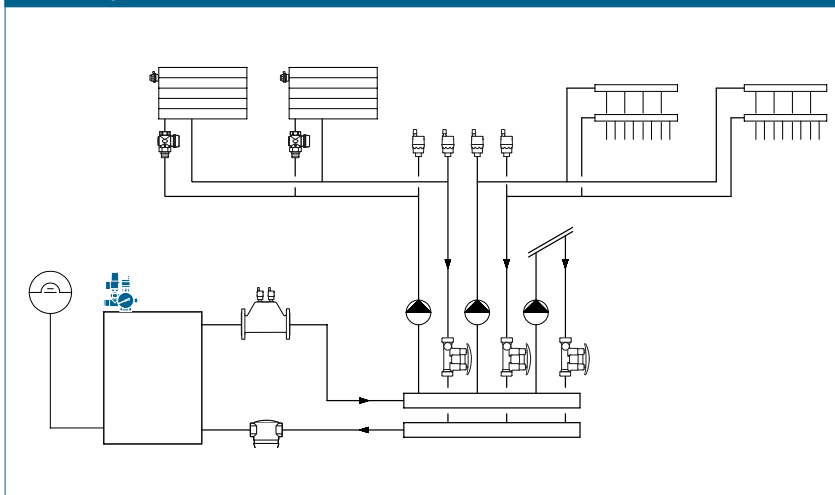

SPECIFICATION TEXT

See www.taconova.com

TECHNICAL DATA

General

- Operating temperature $T_{0\text{ max}}$: 100 °C
- Operating pressure $P_{0\text{ max}}$: see «Type overview»
- Use: Heating systems up to 50 kW
- Additional connections: 3/4" external thread and 1/2" internal thread

Material

- Fitting unit component: Ms 58 brass
- Float vent valve component: Ms 58 brass
- Safety valve component: Ms 58 brass
- Valve spring: stainless steel
- Membrane: elastomer

Fluids

- Heating water (VDI 2035; SWKI BT 102-01; ÖNORM H 5195-1)

TYPE OVERVIEW

TriBloc | Safety group

Order no.	DN	Rp	Safety valve
232.1225.000	25	1"	2,5 bar
232.1230.000	25	1"	3 bar
232.1260.000	25	1"	6 bar

DIMENSIONAL DRAWINGS

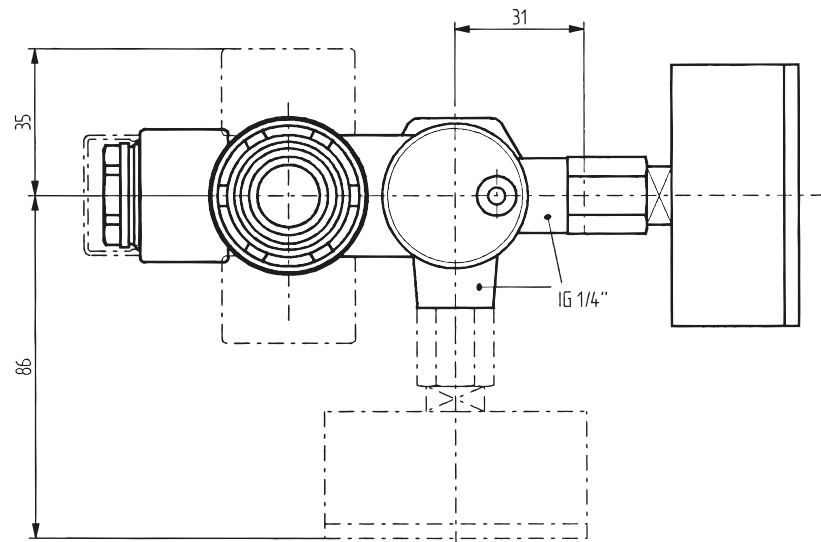
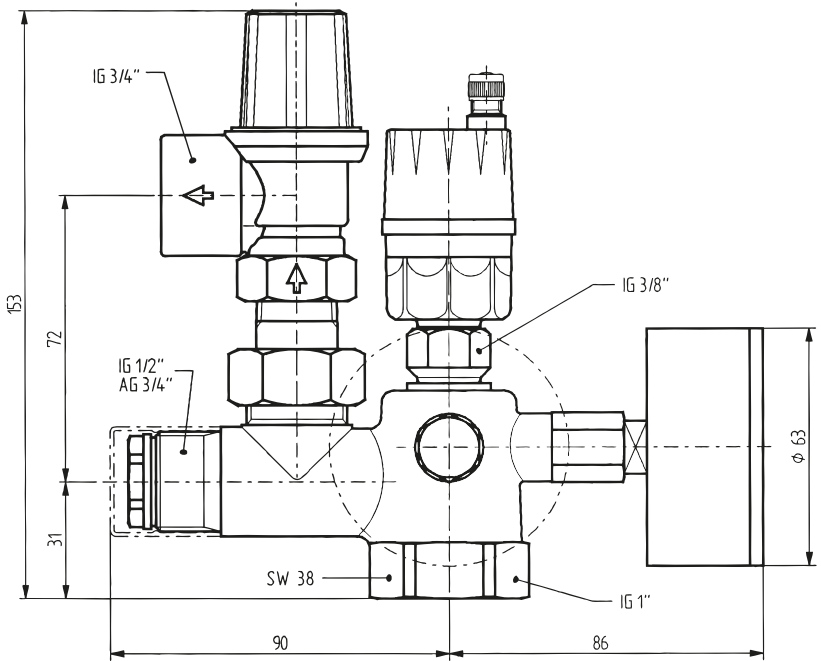

OPERATION PRINCIPLE SAFETY VALVE

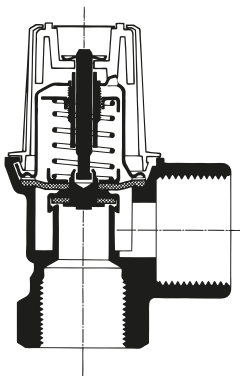

AIR IN HYDRONIC PLANT SYSTEMS

The energy wasted as a result of trapped air in flow systems should not be underestimated. Operational safety and comfort require that air should be drained in all closed-cycle systems.

THERMAL CONDUCTIVITY OF CARRIER MEDIUM IMPAIRED

Air and gases trapped in the heating system reduce heating comfort, impede circulation and reduce energy efficiency. They also diminish the performance and lifetime of the heating system through the formation of erosion and incrustations.

IT IS ALMOST IMPOSSIBLE TO PREVENT THE ENTRY OF AIR

There are different reasons why air enters heating and plumbing systems and why gases are released. This can result from underpressure on the intake side of the circulating pump, for example, or can happen if the system filling pressure is too low, when air is drawn into the pipe system because connections (such as screw connections) are not absolutely air-tight.

Another cause is the change in temperature when the heating water heats up and radiates heat, causing soluble gases in the water to be released. This means that there is a high concentration of air and gas freshly driven from the water at the outlet of the heat flow in the boiler circuit after water has been heated.

VENTILATOR HOUSING FOR HORIZONTAL AND VERTICAL PIPELINES

In order effectively to remove air and released gases from long pipe networks with a large capacity, special air separator housings aid the air and water separation process. The design of the TacoVent Airscoop Horizontal and Airscoop Vertical housing means that the flow is guided in such a way that the air bubbles rise and the accumulated air can be released via the integrated ventilation valves.

REMOVING ACCUMULATED AIR FROM BOILERS, TANKS AND DISTRIBUTORS

Float ventilating valves are used to remove the air from parts of systems such as boilers, storage tanks and the highest points of distribution and connecting lines. The ventilating valve has a float on the surface of the water that holds the ventilating bore tightly closed. When air collects, the float is lowered as the water level drops, opening the air outlet.

AUTOMATIC VENTILATION FUNCTION

There is an expandable membrane in the valve insert of the TacoVent Vent automatic ventilating valve that dries when it comes in contact with air, thus becoming air-permeable. As soon as the air has escaped from the radiator and the membrane is once again comes in contact with hot water, the membrane immediately expands again, preventing water from escaping.

AIR IN THE SOLAR ENERGY CIRCUIT PREVENTS UNIMPEDED CIRCULATION

When a solar thermal system is commissioned and filled for the first time, the trapped air needs to be removed: eddying as the solar liquid flows in can cause air to be absorbed which is only gradually released again during operation. Air and gases are also released during operation due to the occasional evaporation of the anti-freeze mixture. Air in the solar energy system impedes circulation or even blocks it entirely, reducing the solar yield and thus also causing the anti-freeze mixture to age prematurely.

AUTOMATIC VENTILATION FOR SMOOTH SYSTEM OPERATION

In heating systems, vent valves from Taconova can be used to automatically vent trapped air from the system components and pipes even in inaccessible areas.

BENEFITS AT THE PLANNING STAGE

- The range covers all areas where venting is required in heating systems
- Optimized operating costs thanks to energy savings
- Constant heat output with radiators and surface heating systems

BENEFITS AT THE INSTALLATION STAGE

- Fast installation and simple replacement of valves
- Simple ventilation during commissioning and maintenance of heating systems
- Simple and safe operation

Vent valves

The reliable TacoVent vent valves remove unwanted air from heating systems. This increases the efficiency and reduces costs.

- TacoVent HyVent
- TacoVent Vent

APPLICATIONS

Valves and accessories from Taconova can be used in in heating, air conditioning and ventilation systems:

Heating and cooling energy generation

- Oil, gas, electricity, biomass
- District heating

Heating and cooling energy distribution (Indoor temperature control)

- Underfloor heating
- Radiators
- Chilled and heated ceilings

SOLUTIONS FOR EVERY SITUATION

AIR SEPARATOR - CONTINUOUS AIR SEPARATION FOR AUTOMATIC VENTILATION

Operating principle	Description	Advantages	Product variants
Baffle plate 	<p>This technology is based on the breakdown of the water flow into laminar and turbulent flows through integrated flow elements. The special size and positioning of the flow bodies causes a laminar flow in the upper area of the valve. Loosened gas bubbles can rise in the reservoir from this laminar flow area and escape automatically here from the heating system.</p>	<ul style="list-style-type: none"> ▪ High separation performance ▪ Robust, nonsensitive design ▪ Fault and maintenance-free design ▪ Additional connections available from 3" for safety valve or thermometer 	<p>TacoVent AirScoop DH Air Separator (Horizontal)</p> <hr/> <p>TacoVent AirScoop DV Ventilating Flask (Vertical) (principle: cylindrical calming section)</p>

AUTOMATIC VENT VALVE - CONTINUOUS AND AUTOMATIC VENTILATION AND AERATION

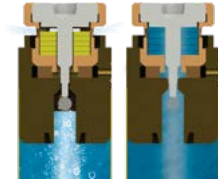
Operating principle	Description	Advantages	Product variants
Float 	<p>When air collects in the vent, the float is lowered as the water level drops, opening the vent valve. As the water level rises, the float closes the air outlet again.</p>	<ul style="list-style-type: none"> ▪ Automatic ventilation of systems during filling and in operation ▪ Automatic aeration of systems when emptying ▪ Design allows dirt-sensitive operation ▪ Trouble-free replacement thanks to a check valve ▪ Time-saving assembly ▪ DN10 with drinking water certification (SVGW) 	<p>TacoVent HyVent Float Vent Valve</p>
Swelling discs 	<p>An expandable membrane in the valve insert dries when it comes in contact with air, thus becoming air-permeable. As soon as the air has escaped from the radiator, the membrane immediately expands again, preventing water from escaping.</p>	<ul style="list-style-type: none"> ▪ Reliable and long-lasting operation ▪ Versatile use ▪ Additional fast manual ventilation ▪ Integrated check valve ▪ Small and compact design ▪ Self-sealing (DN15) 	<p>TacoVent Vent Heating Radiator Vent Valves</p>

TACOVENT VENT

HEATING RADIATOR VENT VALVES



ADVANTAGES

- Reliable, long-life operation
- Versatile application in water-ducting systems
- Additional manual quick-venting
- Built-in automatic check valve requires no draining of the system in case of replacement of the valve insert
- Small and compact design
- Saving of energy by optimal vented system

Permanent and automatic venting.

DESCRIPTION

The TacoVent Vent valves can be used in all systems of water. The valve automatically vents hydraulic systems such as heating radiators, pipe manifolds, pipes, boilers, reservoirs and underfloor heating manifolds on a continuous basis. This automatic function improves operational safety (corrosion reduction) and enhances the user's comfort (no airborne noises). The manual quick-venting allows the fast filling in of the system due to the venting capacity.

INSTALLATION POSITION

Vertically upwards and horizontally.

OPERATION

The automatic operation of the vent valve relies on the special swelling discs built in the valve insert. In dry conditions, the swell discs allow air and gas to escape. The immediate swelling prevents water leakage.

Manual air venting is achieved by undoing the knurled screw and allowing air and gas to escape. Replacement of the valve insert (including seal and swelling discs) is possible due to the automatic check valve integrated in the vent valve. At the first start of operation, it's possible that a few drops come out as long as the swelling discs are dry. This doesn't occur in operation.

BUILDING CATEGORIES

For pipe installations in heating area:

- Apartment blocks, housing estates, multiple dwelling units
- Residential care facilities, hospitals
- Administration and service buildings
- Hotels and restaurants, industrial kitchens
- School buildings and sports facilities
- Commercial and industrial buildings

SYSTEM/BASIC DIAGRAM

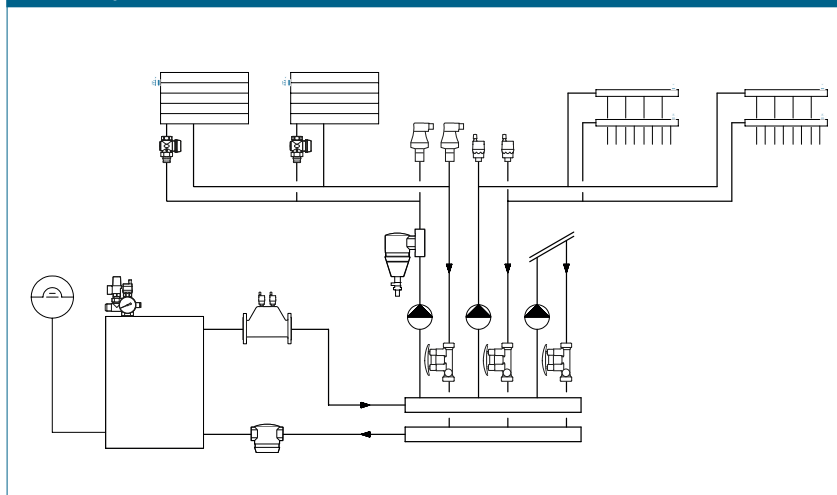

SPECIFICATION TEXT

See www.taconova.com

TECHNICAL DATA

General

- Operating temperature $T_{0\text{ max}}$: 115 °C
- Operating pressure $P_{0\text{ max}}$: 8.5 bar
- Nominal width:
 - $\frac{1}{8}$ " - $\frac{3}{8}$ "
 - $\frac{1}{2}$ " self-sealing (O-ring)

Material

- Valve body: brass nickel-plated
- Valve insert: brass nickel-plated
- Automatic check valve: stainless steel
- Seals: silicone, EPDM

Fluids

- Heating water (VDI 2035; SWKI BT 102-01; ÖNORM H 5195-1)
- Water free of chemical additives

TYPE OVERVIEW

TacoVent Vent | Heating Radiator Vent Valves

Order no.	DN	G	Self-sealing
240.5417.000	6	$\frac{1}{8}$ "	-
240.5418.000	8	$\frac{1}{4}$ "	-
240.5419.000	10	$\frac{3}{8}$ "	-
240.5420.000	15	$\frac{1}{2}$ "	✓

DIMENSIONAL DRAWING

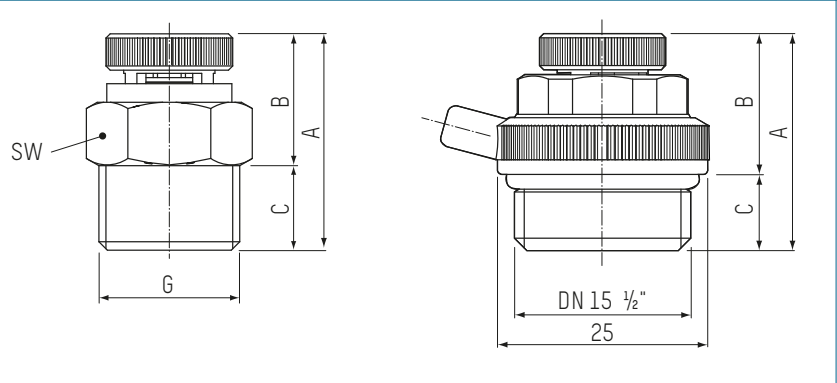

OPERATION PRINCIPLE

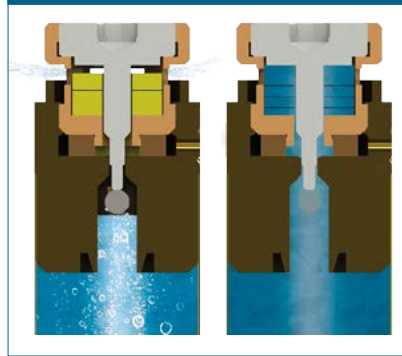

MEASUREMENT TABLE

TacoVent Vent | Heating Radiator Vent Valves

Order no.	G	A	B	C	SW
240.5417.000	$\frac{1}{8}$ "	26	16	10	14
240.5418.000	$\frac{1}{4}$ "	26	16	10	14
240.5419.000	$\frac{3}{8}$ "	26	16	10	17
240.5420.000	$\frac{1}{2}$ "	26	17	9	19

SECTIONAL DRAWING

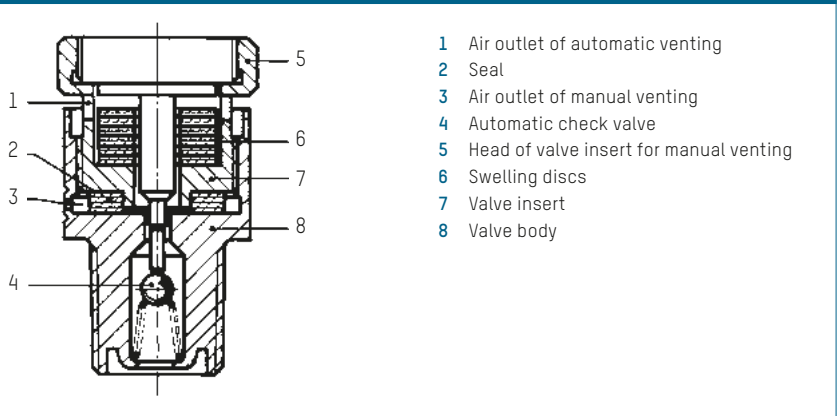

SPARE PART



COMPLETE VALVE INSERT

Order no.	Version
298.4001.000	Including seal and swelling discs

TACOVENT HYVENT

FLOAT AIR VENTILATOR



Permanent and automatic venting and aerating.

DESCRIPTION

The valve automatically vents and provides air from and to hydraulic systems such as heating, cooling, air conditioning and sanitary equipment on a continual basis.

The combination of an air separator with the aerating and venting greatly increases the efficiency of the venting operation. The automatic self-sealing check valve prevents water from escaping from the mains should the vent valve need to be replaced.

INSTALLATION POSITION

Vertically upwards.

OPERATION

The ventilation valve is closed by means of a float. If air collects in the cup, the float sinks and releases the ventilation valve.

The accumulated air escapes until the (inflowing) water pushes the floater down again and the valve closes.

The water once more presses the float against the ventilation valve, and closes the latter. In combination with an upstream TacoVent AirScoop, this guarantees efficient separation of the air-water mixture, and the system is rapidly and automatically vented.

ADVANTAGES

- Automatic air venting of systems during filling or normal operation
- Automatic aerating at draining
- Trouble-free replacement of the float vent valve under full system pressure thanks to a check valve
- Time saving installation of the float vent valve with the automatic check valve

BUILDING CATEGORIES

For pipe installations in heating area:

- Apartment blocks, housing estates, multiple dwelling units
- Residential care facilities, hospitals
- Administration and service buildings
- Hotels and restaurants, industrial kitchens
- School buildings and sports facilities
- Commercial and industrial buildings

SYSTEM/BASIC DIAGRAM

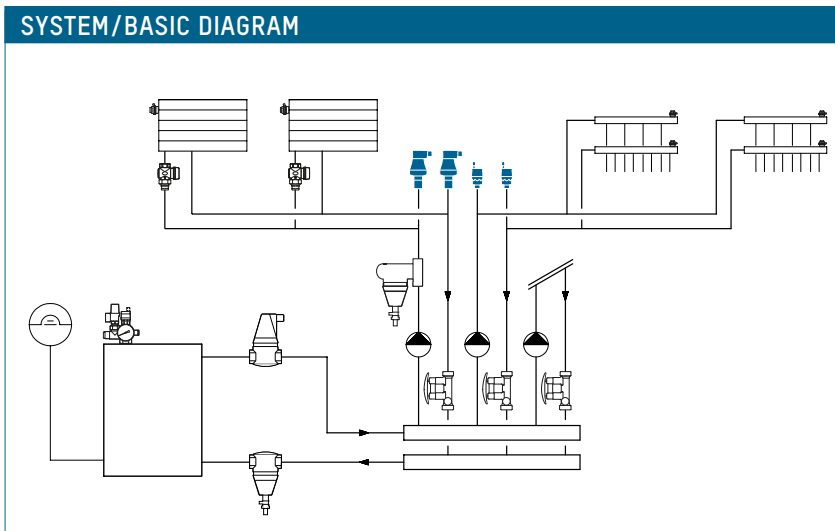

TACOVENT HYVENT DN10

SPECIFICATION TEXT

See www.taconova.com

TECHNICAL DATA

General

- Operating temperature $T_{0\ max}$: 115 °C
- Operating pressure $P_{0\ max}$: 10 bar
- Exterior threads:
G 3/8" and G 1/2" as per ISO 228

Material

- Internal parts: Plastic, stainless steel
- Housing: Brass
- Seals: EPDM, NBR, silicone

Fluids

- Heating water
(VDI 2035; SWKI BT 102-01; ÖNORM H 5195-1)

TYPE OVERVIEW

TacoVent HyVent | Float air ventilator DN10

Order no.	G ¹	Automatic check valve
242.5072.001	3/8"	-
242.5072.002	3/8"	3/8"
242.5072.021	3/8"	1/2"

Automatic check valve DN10

Order no.	G ¹ × G ²	To be used with
220.5235.000	3/8" × 3/8"	242.5072.001, 242.5072.002
220.5236.000	3/8" × 1/2"	242.5072.001, 242.5072.021

DIMENSIONAL DRAWING

Float air ventilator DN10

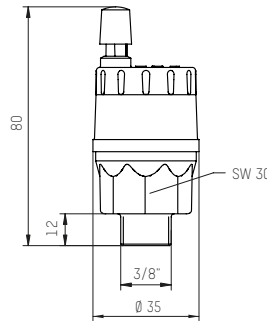

Automatic check valve DN10

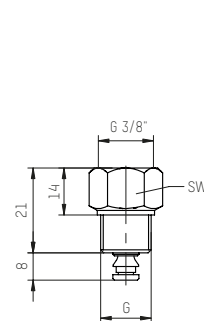

MEASUREMENT TABLE

Check valve DN10

Order no.	G	SW
220.5235.000	3/8"	19
220.5236.000	1/2"	21

OPERATION PRINCIPLE

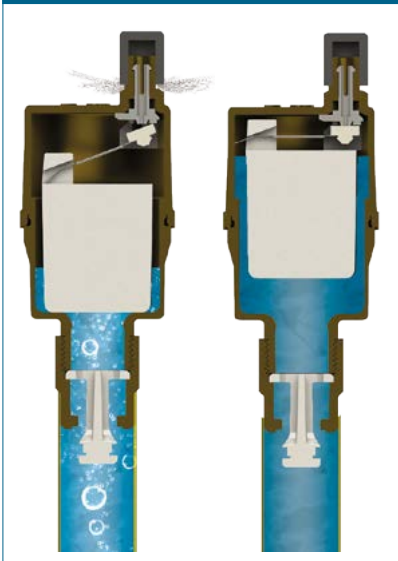

VENTING CAPACITY (DRY VENTING)

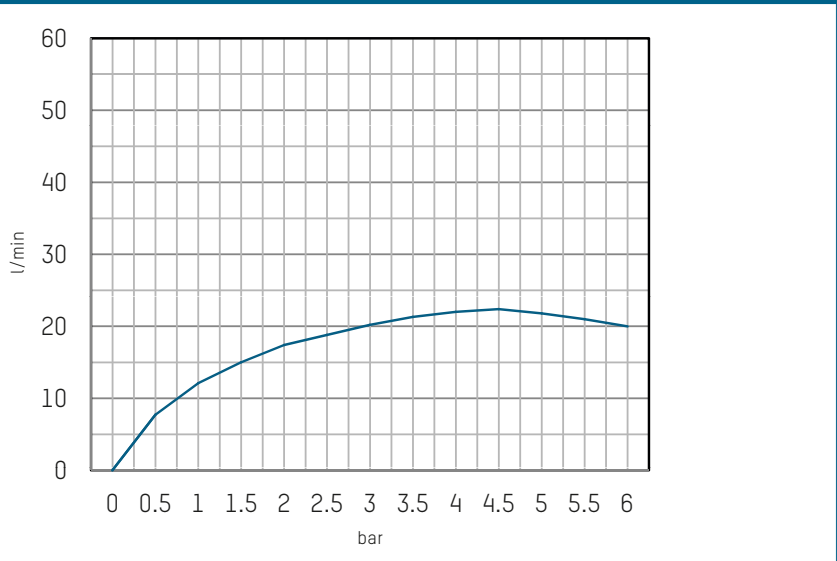

TACOVENT AIRSCOOP D

AIR SEPARATOR



Permanent air separation.

DESCRIPTION

The air separator is fitted in the inlet pipe immediately behind the heating source. This is the point with the highest concentration of air and gas driven out of the water.

The expansion occurring inside the AirScoop and the built-in deflectors speed up the process of separating air and water.

When combined with the float air vent TacoVent HyVent, this system ensures air separation as well as elimination.

TacoVent AirScoop DV is recommended for venting in vertical pipes. The air separated from the medium and collected in the bottle can be vented sporadically via the vent valve.

INSTALLATION POSITION

The horizontal variant may only be installed horizontally and the vertical variant may only be installed vertically. The direction of flow must be kept in mind.

ADVANTAGES

- High air separation capacity
- Strong robust design
- Service and maintenance-free structure
- Two models for horizontal or vertical installation
- Additional connection for safety valve available from dimension 3"

OPERATION

The air expelled from the water into the heating circuit enters the air separator device as air bubbles. The flow-deflector in the housing drives the air bubbles to the top. The collected air is either automatically vented via the TacoVent HyVent (AirScoop horizontal) or manually via the vent valve (AirScoop vertical). The air-separation capacity can be increased by installing a straight piece of piping of approx. 0.5 m in length upstream the separator.

BUILDING CATEGORIES

For pipe installations in heating area:

- Apartment blocks, housing estates, multiple dwelling units
- Residential care facilities, hospitals
- Administration and service buildings
- Hotels and restaurants
- School buildings and sports facilities
- Commercial and industrial buildings

SYSTEM/BASIC DIAGRAM

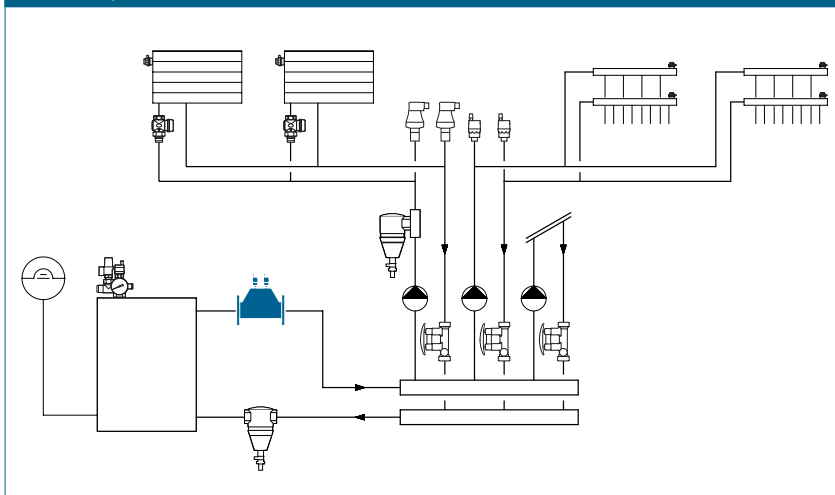

AIRSCOOP HORIZONTAL

SPECIFICATION TEXT

See www.taconova.com

TECHNICAL DATA

General

- Operating temperature $T_{0\text{ max}}$: 135 °C
with float vent valve $T_{0\text{ max}}$: 115 °C
- Operating pressure $P_{0\text{ max}}$: 10 bar

Material

- Housing in cast iron GG 25, lacquered

Fluids

- Heating water
(VDI 2035; SWKI BT 102-01;
ÖNORM H 5195-1)

TYPE OVERVIEW

TacoVent AirScoop DH | Air separator (horizontal), thread connection

Order no.	DN	Rp	Zeta ζ	k_v (m ³ /h)	Weight
243.5001.000	20	¾"	1,1	17,1	0,6 kg
243.5002.000	25	1"	1,0	28,8	0,8 kg
243.5003.000	32	1¼"	1,0	50,4	1,6 kg
243.5004.000	40	1½"	1,1	64,4	3,2 kg
243.5005.000	50	2"	0,84	114,0	3,2 kg
243.5006.000	65	2½"	0,67	237,0	6,8 kg

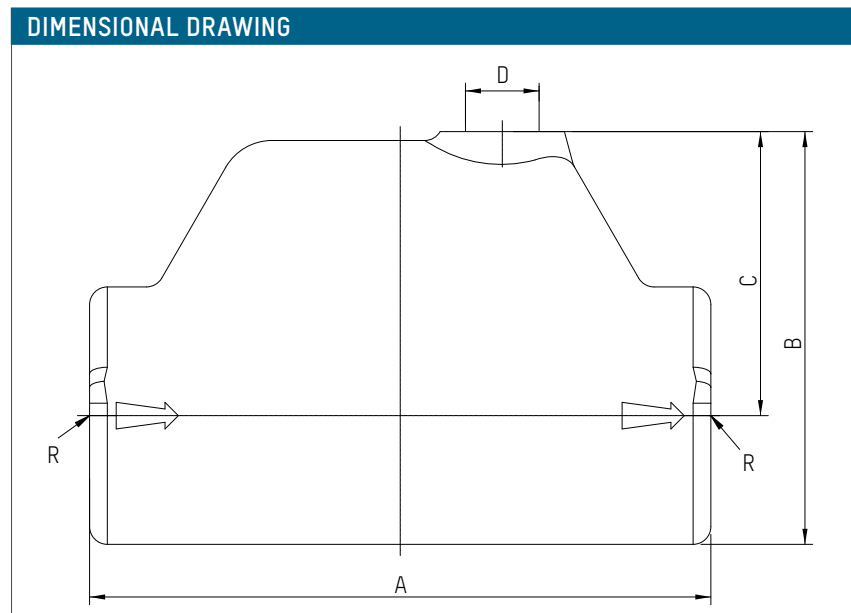
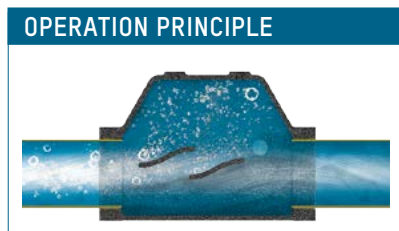

MEASUREMENT TABLE

TacoVent AirScoop DH | Air separator (horizontal)

Order no.	R	A	B	C	D
243.5001.000	Rp ¾"	110	69	48	Rp ¾"
243.5002.000	Rp 1"	120	79	55	Rp ¾"
243.5003.000	Rp 1¼"	140	93	64	Rp ¾"
243.5004.000	Rp 1½"	160	96	64	Rp ¾"
243.5005.000	Rp 2"	228	120	80	Rp ¾"
243.5006.000	Rp 2½"	235	144	95	Rp ¾"

ACCESSORIES



TACOVENT HYVENT

See separate data sheet

Order no.	DN	G	Version
242.5072.001	10	¾"	without automatic check valve
242.5072.002	10	¾"	with automatic check valve

AIRSCOOP VERTICAL

SPECIFICATION TEXT

See www.taconova.com

TECHNICAL DATA

General

- Operating temperature $T_{0\ max}$: 160 °C
- Operating pressure $P_{0\ max}$: 8 bar

Material

- Black steel, stove enamelled

Fluids

- Heating water (VDI 2035; SWKI BT 102-01; ÖNORM H 5195-1)
- Water and proprietary additives used against corrosion and freezing up to 50%

TYPE OVERVIEW

TacoVent AirScoop DV | Ventilating flask (vertical)

Order no.	DN	G	k_v (m ³ /h)
296.7043.000	25	1"	11,1

DIMENSIONAL DRAWING

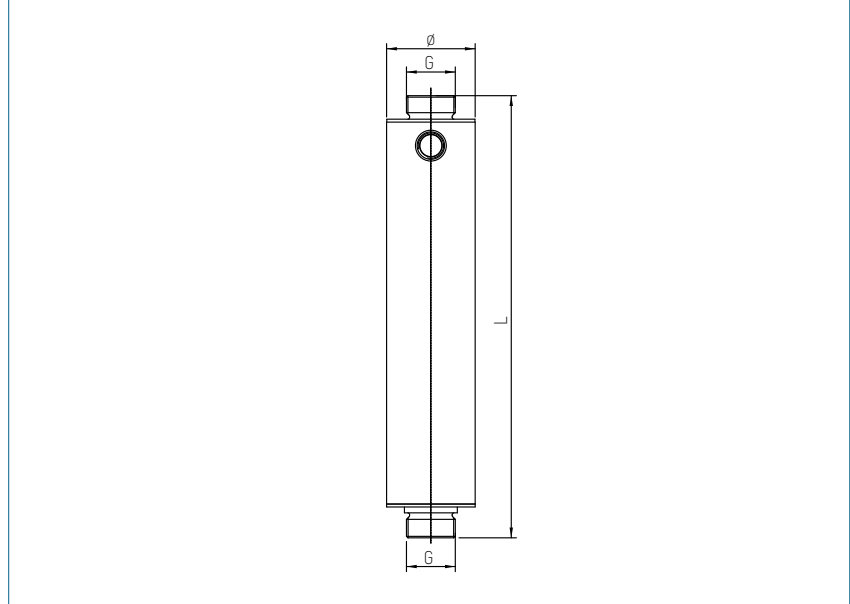

OPERATION PRINCIPLE



MEASUREMENT TABLE

TacoVent AirScoop DV | Ventilating flask, vertical

Order no.	G × G	ø	L
296.7043.000	1" × 1"	60,3 mm	301

MEGAFILL

FILLING UNIT



Filling unit for heating and solar systems in accordance with VDI 2035 Part 1 and 2

DESCRIPTION

Demineralization unit for filling water in heating systems in accordance with VDI Directive 2035 for non-refillable use. By mixing selected ion exchange resins and a pH stabilizer, the water is largely demineralized and at the same time alkalized at pH values of between 8.2 and 9.5 (ALU version max. 8.5).

Since corrosive ions, such as chloride and sulfate, can also be removed, sustainable corrosion protection can be achieved.

INSTALLATION

According to DIN standards, a system separator must be connected to the fresh water supply prior to filling. A water meter should then be connected to measure the filling volume. For best results, the flow rate should not exceed 10 l/min during filling with the MegaFill 5000. This can likewise be checked using the water meter or an optional TacoSetter. You can use two simple pieces of tubing with $\frac{3}{4}$ " connection to then connect MegaFill to the heating system in the direction of flow (arrow) and now fill the system. Make sure to take note of the previously calculated maximum capacity.

ADVANTAGES

- Prevention of damage in hot water heating systems
- Filling in accordance with VDI 2035 Part 1 and 2
- Preservation of warranty in case of damage
- Three functions combined in one: decalcification, desalination, pH stabilization
- No corrosion, no scale formation
- Improved energy utilization since no lime precipitates
- Low costs
- Also suitable for retrofitting, thereby extending the lifetime of the heating system
- Simple installation and handling

MegaFill can be removed after filling and the heating system vented as usual. Used MegaFill 5000 filling units can be disposed of with residual waste.

OPERATION

The cartridge contains a mixed bed resin with anion and cation exchangers and a pH stabilizer that neutralize salts and carbonates in the drinking water.

BUILDING CATEGORIES

For pipe installations in drinking water, heating and cooling areas:

- Apartment blocks, housing estates
- Multiple dwelling units
- Residential care facilities and hospitals
- Administration and service buildings
- Hotels and restaurants, industrial kitchens
- School buildings and sports halls / sports facilities
- Commercial and industrial buildings
- Facilities with partial use, such as barracks, camping sites

SYSTEM/BASIC DIAGRAM

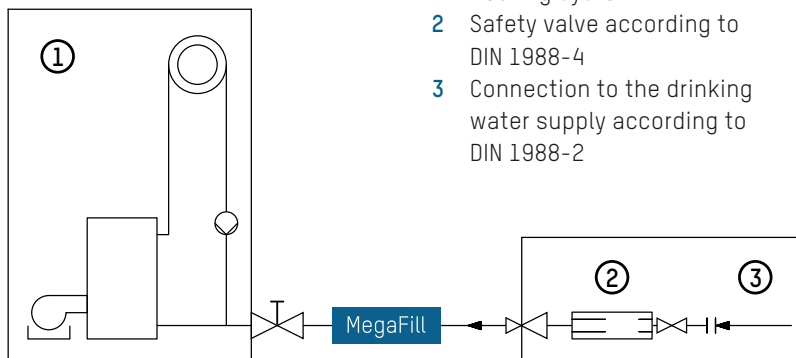

TENDER TEXT

See www.taconova.com

TECHNICAL DATA

General

- Max. filling temperature $T_{F,max}$ 50 °C
- Max. operating pressure $P_{0,max}$ 6 bar
- Capacity approx. 5000 d/l
- Dimensions and weight: see type overview

Flow media

- Heating water (VDI 2035; SWKI BT 102-01; ÖNORM H 5195-1)
- Cold water according to DIN 1988-7

NOTE

For customers of Taconova Group AG on request.

TYPE OVERVIEW

MegaFill 5000 | Filling Unit

Weight: 5.5 kg; width (D): 125 mm; length (b1): 577 mm, for systems with/without aluminum components

Order no.	DN	G (d1)	pH range
298.5041.000	20	3/4"	max. 8,5

DIMENSIONAL DRAWING

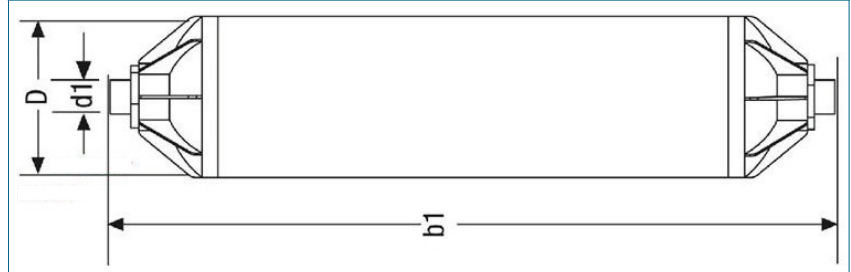

MAXIMUM HARDNESS FOR FILLING WATER IN HEATING SYSTEMS

Boiler output P in kW \ SAV	SAV	SAV < 20 l/kW	20 l/kW < SAV < 50 l/kW	SAV > 50 l/kW
P ≤ 50		≤ 16,8 (with circulation heating)	≤ 11,2	< 0,1
50 < P ≤ 200		≤ 11,2	≤ 8,4	< 0,1
200 < P ≤ 600		≤ 8,4	< 0,1	< 0,1
P > 600		< 0,1	< 0,1	< 0,1

You need the boiler output and the specific system volume (S AV) to establish the required target hardness. The boiler output P is stated in kW, the specific system volume is derived from the system volume in l divided by the boiler output in kW and is stated in l/kW. You can calculate the maximum permitted hardness for the filling water in the heating system for the respective application on the basis of the next diagram.

CAPACITY OF WATER WITH LOW SALT CONTENT

Target hardness: 0,1 °d

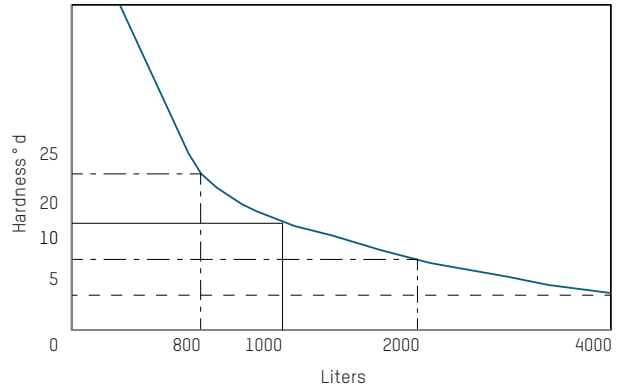
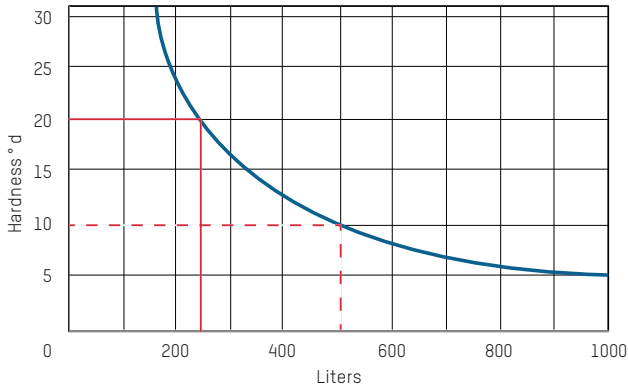

TABLE FOR CALCULATING THE REQUIRED NUMBER OF MEGAFILL FILLING UNITS

TARGET HARDNESS 8,4 °d

Vol.	GH					
	5 °d	10 °d	15 °d	20 °d	25 °d	
200 l	1	1	1	1	1	
500 l	1	1	2	3		
			(1 × 240 l) NFW 260 l	(2 × 175 l) NFW 150 l	(3 × 140 l) NFW 80 l	
1000 l	1	1	4	5		
			(2 × 240 l) NFW 520 l	(4 × 175 l) NFW 300 l	(5 × 140 l) NFW 300 l	
1500 l	1	1	3	5	7	
			(1 × 500 l) NFW 1000 l	(1 × 350 l) NFW 1150 l	(3 × 240 l) NFW 780 l	(5 × 175 l) NFW 625 l
2000 l	2	2	4	7	10	
			(2 × 500 l) NFW 1000 l	(2 × 350 l) NFW 1300 l	(4 × 240 l) NFW 1040 l	(7 × 175 l) NFW 775 l

In accordance with VDI 2035, all hardeners only have to be removed with a heat output of P > 600 kW or a SAV > 5 l/kW. Softening to 8,4 °d or 11,2 °d only is required in other cases. A raw water blend therefore makes sense.

TARGET HARDNESS 11,2 °d

Vol.	GH					
	5 °d	10 °d	15 °d	20 °d	25 °d	
200 l	1	1	1	1	1	
500 l	1	1	2	2		
			(1 × 240 l) NFW 260 l	(2 × 175 l) NFW 150 l	(2 × 140 l) NFW 220 l	
1000 l	1	1	3	4		
			(1 × 500 l) NFW 500 l	(1 × 350 l) NFW 650 l	(2 × 240 l) NFW 520 l	(3 × 175 l) NFW 475 l
1500 l	1	1	3	4	6	
			(1 × 500 l) NFW 1000 l	(1 × 350 l) NFW 1150 l	(3 × 240 l) NFW 780 l	(4 × 175 l) NFW 800 l
2000 l	2	2	4	5	8	
			(2 × 500 l) NFW 1000 l	(2 × 350 l) NFW 1300 l	(4 × 240 l) NFW 1040 l	(5 × 175 l) NFW 1125 l

In order to measure the relevant parameters, such as conductivity, pH value and hardness, we recommend inclusion of an analysis kit in the tenders. The filling criteria according to E 1717 are moreover fulfilled with the system separator.

TARGET HARDNESS 16,8 °d

Vol.	GH					
	5 °d	10 °d	15 °d	20 °d	25 °d	
200 l	1	1	1	1	1	
500 l	1	1	2	2		
			(1 × 240 l) NFW 260 l	(1 × 175 l) NFW 325 l	(2 × 140 l) NFW 220 l	
1000 l	1	1	3	3		
			(1 × 500 l) NFW 500 l	(1 × 350 l) NFW 650 l	(1 × 240 l) NFW 780 l	(2 × 175 l) NFW 650 l
1500 l	1	1	2	3	4	
			(1 × 500 l) NFW 1000 l	(1 × 350 l) NFW 1150 l	(2 × 240 l) NFW 1020 l	(3 × 175 l) NFW 975 l
2000 l	2	2	3	4	5	
			(2 × 500 l) NFW 1000 l	(2 × 350 l) NFW 1300 l	(3 × 240 l) NFW 1280 l	(4 × 175 l) NFW 1300 l

Key
5 Number of MegaFill Demineralization units
 (5 × 140 l) Capacity in liters per MegaFill
 NFW 1300 l Raw water content in liters

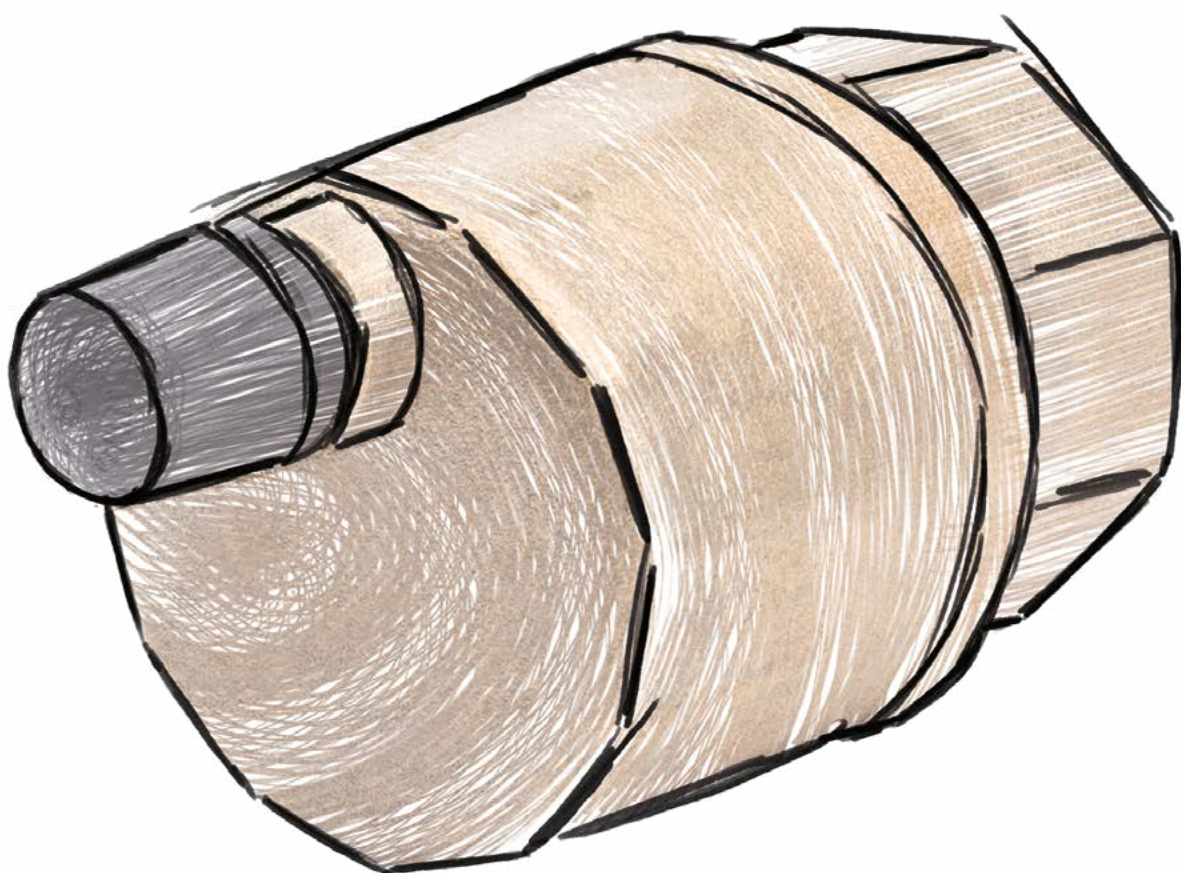



PUMP TECHNOLOGY

Pumps are at the heart of hydraulic heating and cooling systems in buildings. They ensure the reliable transport of the required energy and thus provide a comfortable building climate. A wide range of suitable pumps in combination with balancing valves from Taconova ensure efficient heat distribution. This increases the energy efficiency of heating systems and therefore reduces operating costs. Renowned customers have been using these reliable, high quality products for many years.

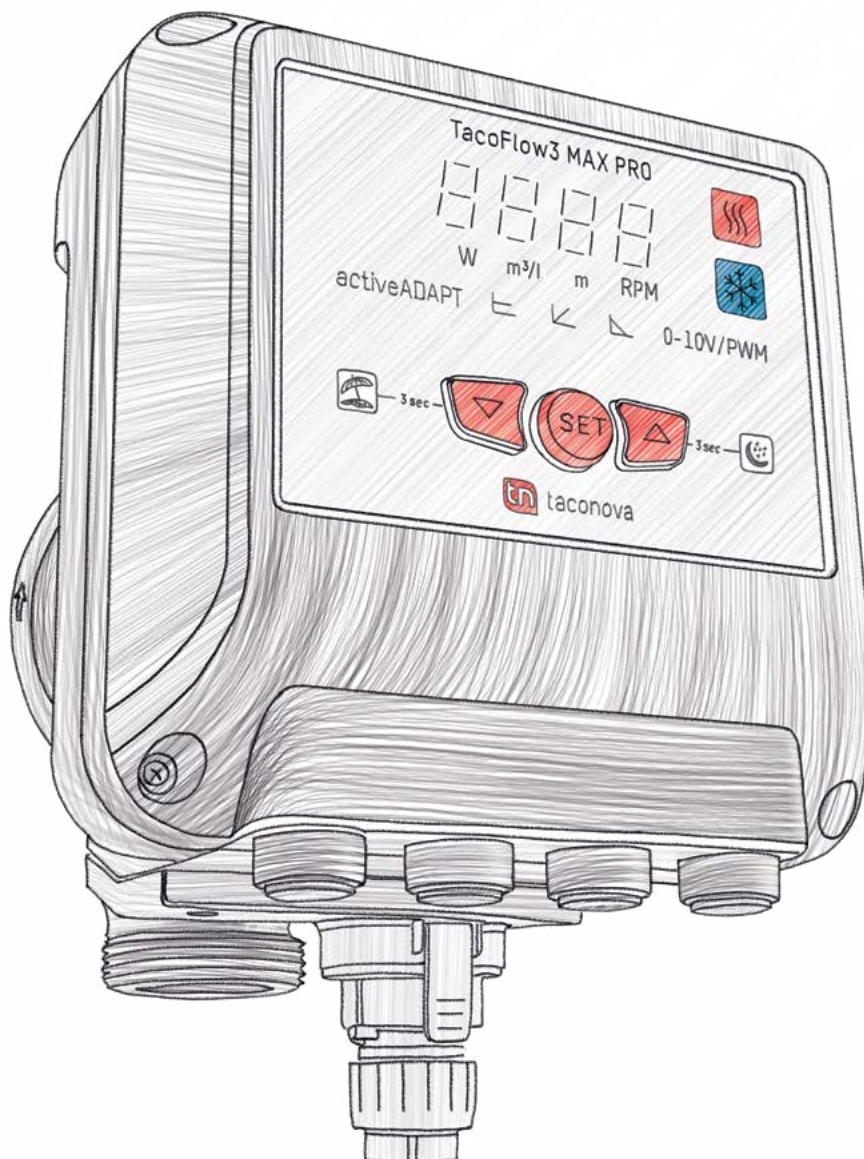

BETWEEN HEAT GENERATOR AND HEAT DISTRIBUTION

Pump technology is a new addition to Taconova's comprehensive range. This proven, yet innovative, technology has been developed and refined over many years at Taconova's parent and subsidiary companies Taco Inc. and Taco Italia. As of 2019, circulation pumps will be part of the Taconova product range. All pumps now feature a plug & play connection.

OVERVIEW OF PRODUCT GROUPS



VERSATILE PUMPS

These heating circuit pumps are divided into three categories: TacoFlow2, driven by a permanent synchronous motor and adjustable via three setting functions (min./max., proportional pressure and constant pressure). The TacoFlow2 ADAPT circulation pump with activeADAPT function, which automatically adjusts the pump rate to the specific requirements of the system. In addition to the activeADAPT functions, the TacoFlow2 eLink makes it possible to adjust pump settings wirelessly via smart devices (mobile phone or tablet). This allows additional, even finer adjustments, and the selected settings can be saved and logged.



POWERFUL PUMPS

In the area of heating and cooling, TacoFlow MAX pumps cover a wider performance spectrum, especially for commercial applications. New to the range: TacoFlow3 MAX with rotary selector for setting the required functions. TacoFlow3 MAX PRO offers numerous additional functions – for example, the ability to show operating conditions such as the flow rate, heat amount and current energy consumption directly on the display screen.



SUSTAINABLE PUMPS

In the field of solar thermal systems, TacoFlow2 SOLAR circulation pumps enable the use of solar energy for heat generation. The use of this renewable energy reduces the need for fossil fuels, which is good news for the environment.



PURE PUMPS

The TacoFlow2 PURE (C) DHW circulation pumps for potable water systems ensure that hygienic domestic hot water is always available. In addition, it prevents water being wasted, as hot water is immediately available when required, which also increases user convenience.

OPTIMUM DISTRIBUTION OF VOLUME FLOW TO CONSUMERS

Circulation pumps supply various consumers with the required volume flow. This ensures a comfortable room climate or faster availability of hot water at the tap, and increases convenience.

HIGHLY EFFICIENT CIRCULATION PUMPS

TacoFlow circulation pumps comply with the ErP Directive – and with their low EEl (Energy Efficiency Index) of < 0.20, they are among the most efficient on the market. They are used in residential and commercial buildings. In combination with hydronic balancing, they are eligible for subsidies in some countries.

THE RIGHT PUMP SETTING FOR EVERY APPLICATION

Our heating pumps feature a broad range of possible operating modes. The options available are as follows: proportional pressure, constant pressure, activeADAPT and a fixed min./max. speed. These options can be selected according to the respective application.

THE RIGHT PUMP FOR EVERY APPLICATION

The product range includes circulation pumps for heating, cooling, solar and domestic hot water. The use of high grade materials ensures a long service life. They also stand apart through their efficient operation.

TACONOVA REPLACEMENT GUIDE



Find the right TacoFlow pump for your project in two easy steps.



HIGH EFFICIENCY CIRCULATION PUMPS FOR VARIOUS BUILDING TECHNOLOGY APPLICATIONS

The entire range of Taconova circulation pumps is driven by synchronous motors with permanent magnet technology, which ensures efficient operation.

BENEFITS AT THE PLANNING STAGE

- Safety at the design stage, thanks to a large number of built-in safety functions
- Meets the energy requirements of the relevant legislation (ErP 2009/125/EC)
- Can be adapted to suit any system situation thanks to a large number of operating modes

ADVANTAGES AT THE INSTALLATION STAGE

- Straightforward installation of the circulation pumps
- Various operating mode settings, recognisable at a glance via LEDs
- 5 year guarantee on heating circuit pumps
- Minimal space requirement due to compact design
- Reliable operation thanks to high quality components

High efficiency circulation pumps

TacoFlow are circulation pumps featuring a glandless design. This means that all rotating parts of the motor are flushed with the pumped medium, which has a cooling and lubricating effect on the individual components. The range includes various circulation pumps for heating, cooling, solar and domestic hot water applications, which deliver the required flow rate to the corresponding consumers.

- TacoFlow2
- TacoFlow2 ADAPT
- TacoFlow2 eLink
- TacoFlow3 MAX
- TacoFlow3 MAX PRO
- TacoFlow2 SOLAR
- TacoFlow2 PURE (C)

APPLICATIONS

Taconova circulation pumps can be used widely in sanitary and HVAC systems:

Heating and cooling energy generation	Heating and cooling energy distribution (Indoor temperature control)	Sanitary systems
<ul style="list-style-type: none"> ▪ Solar thermal energy ▪ Oil, gas, electricity, biomass ▪ District heating 	<ul style="list-style-type: none"> ▪ Underfloor heating ▪ Radiators ▪ Chilled and heated ceilings 	<ul style="list-style-type: none"> ▪ Fresh water

BROCHURE PUMP TECHNOLOGY



TACOFLOW2 (C A)

HEATING CIRCUIT PUMPS



Glandless circulator pumps for hot water heating systems in residential and commercial buildings.

DESCRIPTION

The TacoFlow2 is driven by permanent-magnet synchronous motors. These innovative motors achieve a high efficiency at low operating costs.

They are maintenance-free and do not need replacement of seals and gaskets.

INSTALLATION POSITION

The pump can be installed both horizontally or vertically. The arrow indicating the medium's flow direction must be observed.

ADVANTAGES

- Efficient throughput setting with variable Δp -v proportional pressure curves, constant-pressure curves Δp -c or fixed Min-Max speed
- Media temperature range from +2 °C to +95 °C
- A colour LED indicates the current operating state

OPERATION

The circulation pump are of a glandless design, since the rotating parts of the motor run inside the pumped medium. This provides lubrication for the motor and the rotating parts. The circulation pump is equipped with anti-blocking protection, since the high efficiency pumps no longer have a pump head screw for manual unblocking. They also feature an automatic venting function, which detects and indicates any air in the pump.

BUILDING CATEGORIES

- Apartment blocks, single family dwellings, housing estates, multiple dwelling units
- Smaller public buildings
- Hotels and restaurants, industrial kitchens
- School buildings and sports facilities
- Office, commercial and industrial buildings
- Facilities with partial use, such as barracks, camping sites

SYSTEM/BASIC DIAGRAM

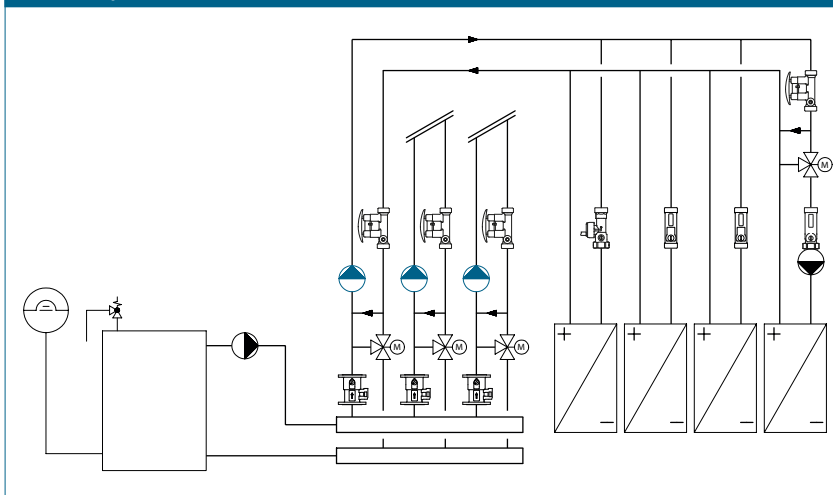

SPECIFICATION TEXT

See www.taconova.com

TECHNICAL DATA

Pump

- Ambient temperature: +0 °C to +40 °C
- Permissible temperature range*: +2 °C to +95 °C
- Permissible temperature ranges at max. ambient temperature:
 - at 30 °C: +30 °C to +95 °C
 - at 35 °C: +35 °C to +90 °C
 - at 40 °C: +40 °C to +70 °C
- Static pressure: Max. 0.6 MPa - 6 bar
- Minimum pressure at air intake:
 - 0.03 MPa (0.3 bar) at 50 °C
 - 0.10 MPa (1.0 bar) at 95 °C
- Max. relative humidity: ≤ 95%
- Sound pressure level: <43 dB (A)
- Low Voltage Directive (2006/95/EC): Standards applied: EN 62233, EN 60335-1 and EN 60335-2-51
- EMC Directive (2004/108/EC); Standards applied: EN 61000-3-2, EN 61000-3-3, EN 55014-1 and EN 55014-2
- Ecodesign Directive (2009/125/EC); Standards applied: EN 16297-1 and EN 16297-2

Material

- Pump body: Cast iron, CDP-coated (EN-GJL-200)
- Impeller: Composite plastic
- Shaft: Ceramic
- Bearing: Graphite
- Axial thrust bearing: Ceramic
- Can: Composite plastic

* To prevent condensate in the motor and on the control electronics, the temperature of the pumped medium must always be higher than the ambient temperature.

TECHNICAL DATA (CONTINUED)

Motor and electronics

- Supply voltage: 1x230 V (±10%); frequency: 50/60 Hz
- Pump power plug
- Power rating (P1): Min. 3 W, max. 42 W
- Rated current (I1): Min. 0.03 A, max. 0.33 A
- Insulation class: H
- Protection rating: IP 44
- Safety category: II

TECHNICAL DATA (CONTINUED)

Fluids

- Heating water (VDI 2035; SWKI BT 102-01; ÖNORM H 5195-1)
- Water and proprietary additives used against corrosion and freezing up to 30 %

TYPE OVERVIEW

TacoFlow2 | Heating circuit pumps
Cast iron high efficiency pump with plug connection.
Pump head: 6 m

Order no.	Designation	Connection	Centre distance	Weight
302.2231.000	15-60/130	G 1"	130 mm	1,67 kg
302.4231.000	25-60/130	G 1 ½"	130 mm	1,81 kg
302.5231.000	25-60/180	G 1 ½"	180 mm	1,96 kg
302.6231.000	32-60/180	G 2"	180 mm	2,10 kg

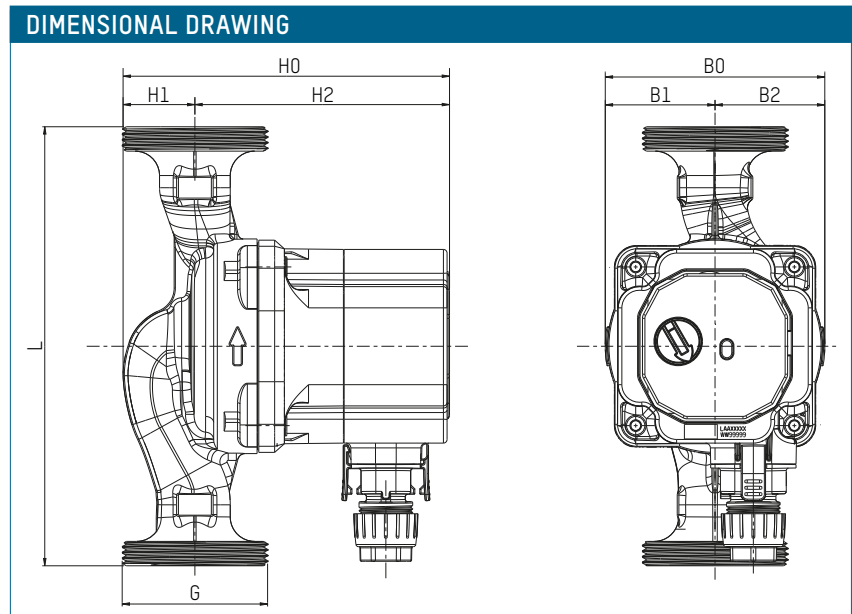

MEASUREMENT TABLE

Order no.	L	B0	B1	B2	H0	H1	H2
302.2231.000	130	90	45	45	133,8	29,4	104,4
302.4231.000	130	90	45	45	133,8	29,4	104,4
302.5231.000	180	90	45	45	133,8	29,4	104,4
302.6231.000	180	90	45	45	133,8	29,4	104,4

ENERGY EFFICIENCY INDEX

EEI ≤ 0,20 - Part 2

Reference value for the most efficient circulation pump is EEI ≤ 0.20

PERFORMANCE CURVES

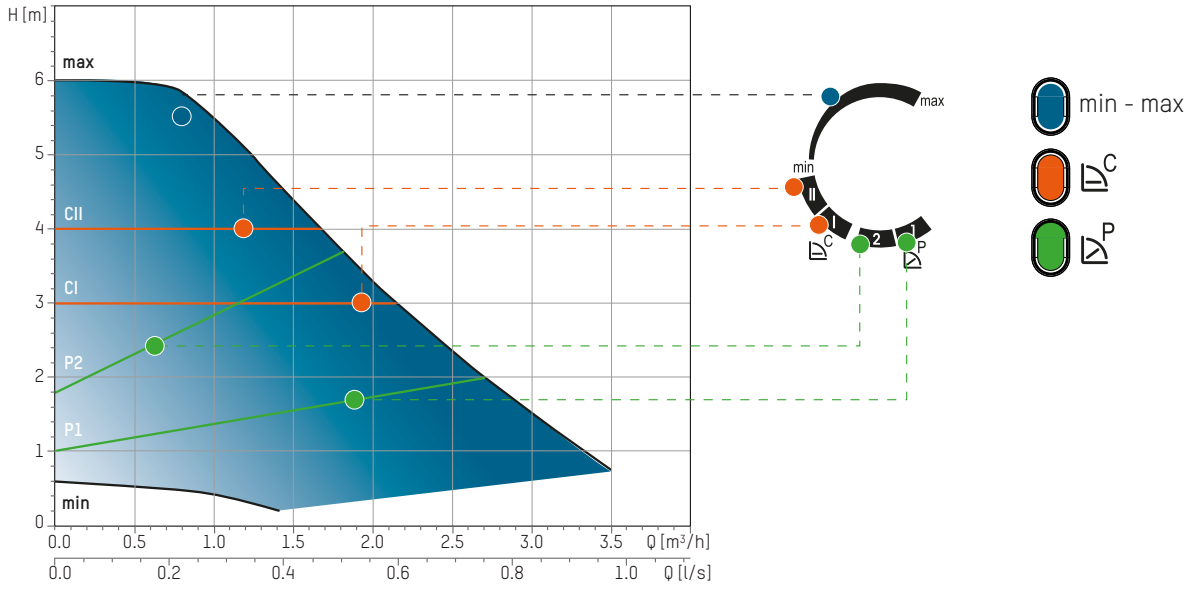

Q [m³/h]	0.4	0.8	1.2	1.6	2	2.4	2.8	3.2
H [m]	6	5.9	5	4.4	3.4	2.6	2.8	1.2

POWER CONSUMPTION CURVES

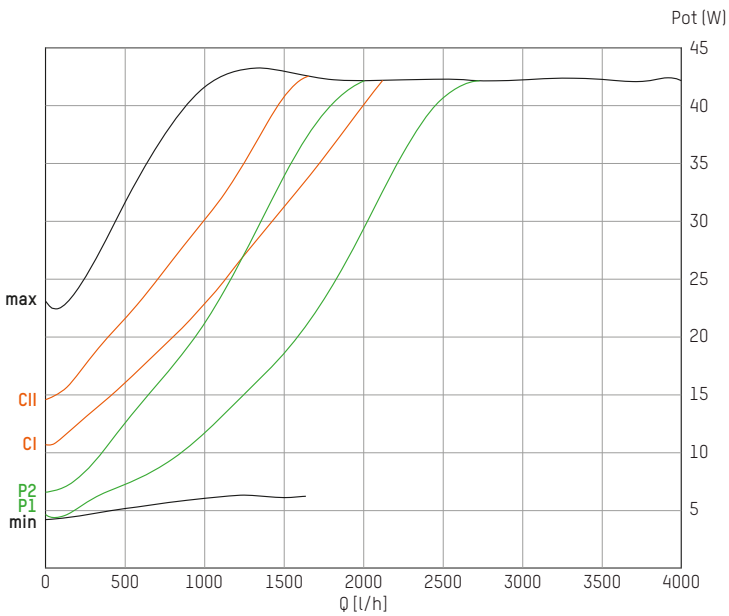

SPECIFICATION TEXT

See www.taconova.com

TECHNICAL DATA

Pump

- Ambient temperature: +0 °C to +40 °C
- Permissible temperature range*: +2 °C to +95 °C
- Permissible temperature ranges at max. ambient temperature:
 - at 30 °C: +30 °C to +95 °C
 - at 35 °C: +35 °C to +90 °C
 - at 40 °C: +40 °C to +70 °C
- Static pressure: Max. 0.6 MPa - 6 bar
- Minimum pressure at air intake:
 - 0.03 MPa (0.3 bar) at 50 °C
 - 0.10 MPa (1.0 bar) at 95 °C
- Max. relative humidity: ≤ 95%
- Sound pressure level: <43 dB (A)
- Low Voltage Directive (2006/95/EC): Standards applied: EN 62233, EN 60335-1 and EN 60335-2-51
- EMC Directive (2004/108/EC); Standards applied: EN 61000-3-2, EN 61000-3-3, EN 55014-1 and EN 55014-2
- Ecodesign Directive (2009/125/EC); Standards applied: EN 16297-1 and EN 16297-2

Material

- Pump body: Cast iron, CDP-coated (EN-GJL-200)
- Impeller: Composite plastic
- Shaft: Ceramic
- Bearing: Graphite
- Axial thrust bearing: Ceramic
- Can: Composite plastic

* To prevent condensate in the motor and on the control electronics, the temperature of the pumped medium must always be higher than the ambient temperature.

TECHNICAL DATA (CONTINUED)

Motor and electronics

- Supply voltage: 1x230 V (±10%); frequency: 50/60 Hz
- Pump power plug
- Power rating (P1): Min. 3 W, max. 56 W
- Rated current (I1): Min. 0.03 A, max. 0.44 A
- Insulation class: H
- Protection rating: IP 44
- Safety category: II

TECHNICAL DATA (CONTINUED)

Fluids

- Heating water (VDI 2035; SWKI BT 102-01; ÖNORM H 5195-1)
- Water and proprietary additives used against corrosion and freezing up to 30 %

TYPE OVERVIEW

TacoFlow2 | Heating circuit pumps
Cast iron high efficiency pump with plug connection.
Pump head: 7 m

Order no.	Designation	Connection	Centre distance	Weight
302.2241.000	15-70/130	G 1"	130 mm	1,91 kg
302.4241.000	25-70/130	G 1 ½"	130 mm	2,05 kg
302.5241.000	25-70/180	G 1 ½"	180 mm	2,20 kg
302.6241.000	32-70/180	G 2"	180 mm	2,34 kg

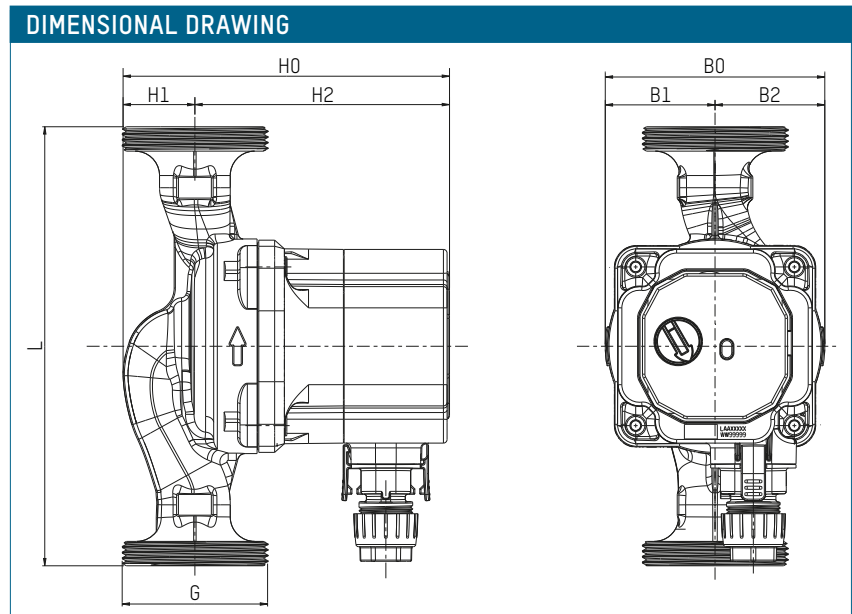

MEASUREMENT TABLE

Order no.	L	B0	B1	B2	H0	H1	H2
302.2242.000	130	90	45	45	143,8	29,4	114,4
302.4242.000	130	90	45	45	143,8	29,4	114,4
302.5242.000	180	90	45	45	143,8	29,4	114,4
302.6242.000	180	90	45	45	143,8	29,4	114,4

ENERGY EFFICIENCY INDEX

EEI ≤ 0,21 - Part 2

Reference value for the most efficient circulation pump is EEI ≤ 0.20

PERFORMANCE CURVES

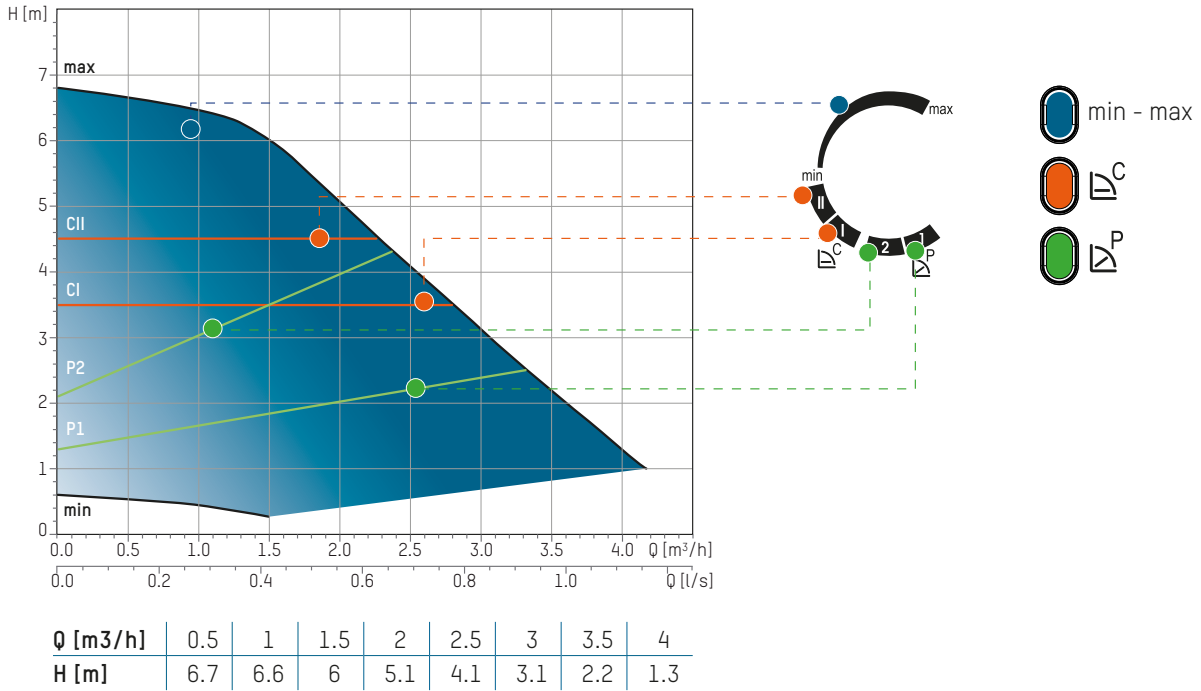

POWER CONSUMPTION CURVES

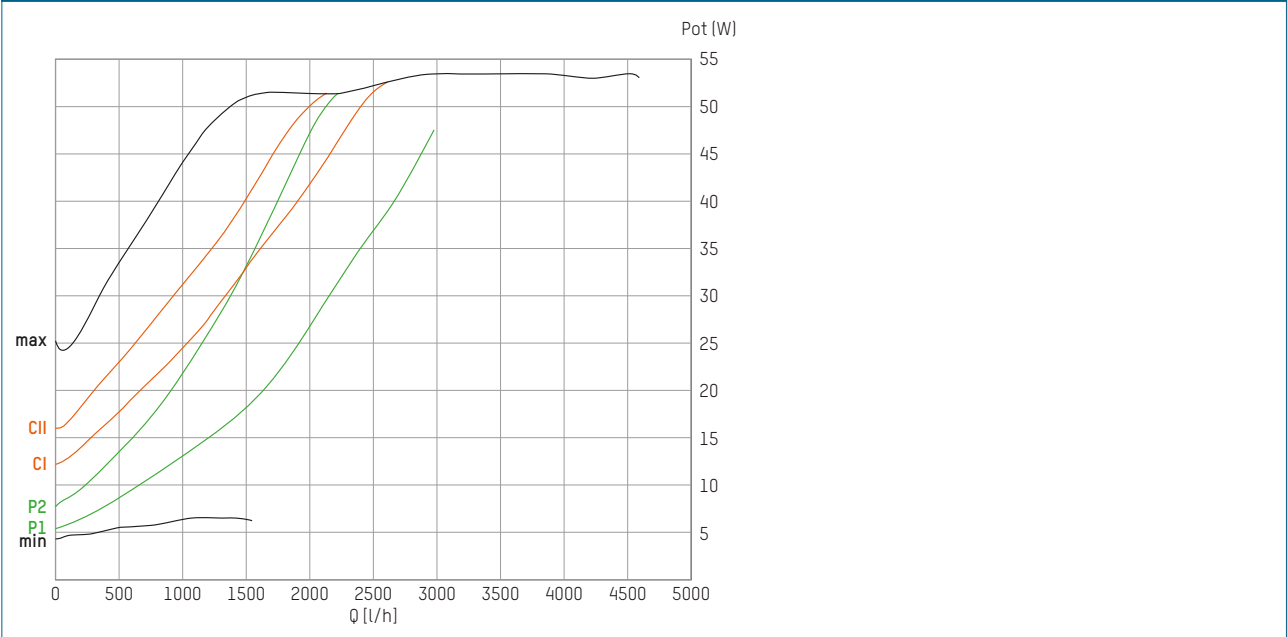

SPECIFICATION TEXT

See www.taconova.com

TECHNICAL DATA

Pump

- Ambient temperature: +0 °C to +40 °C
- Permissible temperature range*: +2 °C to +95 °C
- Permissible temperature ranges at max. ambient temperature:
 - at 30 °C: +30 °C to +95 °C
 - at 35 °C: +35 °C to +90 °C
 - at 40 °C: +40 °C to +70 °C
- Static pressure: Max. 0.6 MPa - 6 bar
- Minimum pressure at air intake:
 - 0.03 MPa (0.3 bar) at 50 °C
 - 0.10 MPa (1.0 bar) at 95 °C
- Max. relative humidity: ≤ 95%
- Sound pressure level: <43 dB (A)
- Low Voltage Directive (2006/95/EC): Standards applied: EN 62233, EN 60335-1 and EN 60335-2-51
- EMC Directive (2004/108/EC); Standards applied: EN 61000-3-2, EN 61000-3-3, EN 55014-1 and EN 55014-2
- Ecodesign Directive (2009/125/EC); Standards applied: EN 16297-1 and EN 16297-2

Material

- Pump body: Composite plastic PA 66GF
- Impeller: Composite plastic
- Shaft: Ceramic
- Bearing: Graphite
- Axial thrust bearing: Ceramic
- Can: Composite plastic

* To prevent condensate in the motor and on the control electronics, the temperature of the pumped medium must always be higher than the ambient temperature.

TECHNICAL DATA (CONTINUED)

Motor and electronics

- Supply voltage: 1x230 V (±10%); frequency: 50/60 Hz
- Pump power plug
- Power rating (P1): Min. 3 W, max. 42 W
- Rated current (I1): Min. 0.03 A, max. 0.33 A
- Insulation class: H
- Protection rating: IP 44
- Safety category: II

TECHNICAL DATA (CONTINUED)

Fluids

- Heating water (VDI 2035; SWKI BT 102-01; ÖNORM H 5195-1)
- Water and proprietary additives used against corrosion and freezing up to 30 %

TYPE OVERVIEW

TacoFlow2 C A | Heating circuit pumps with air separator
 Composite plastic high efficiency pump with plug connection.
 Pump head: 6 m

Order no.	Designation	Connection	Centre distance	Weight
302.2134.000	C A 15 - 60/130	G 1"	130 mm	1,25 kg

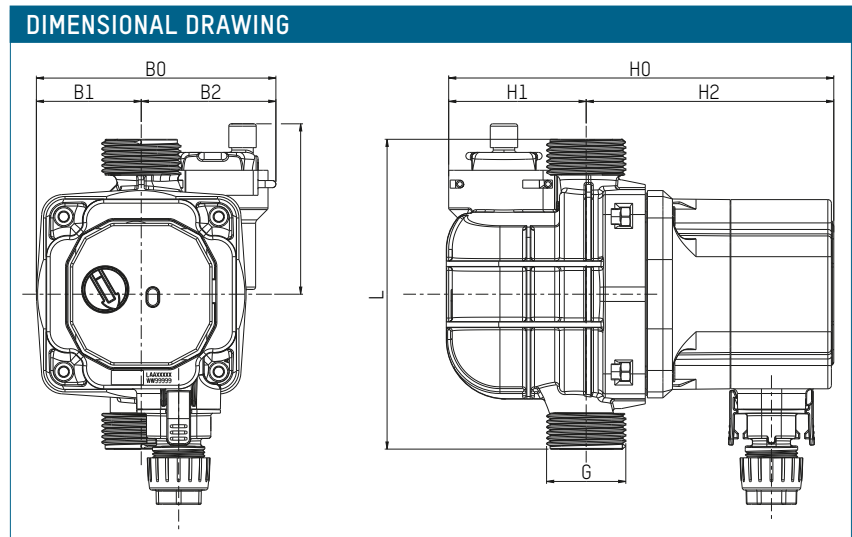

MEASUREMENT TABLE

Order no.	L	L1	B0	B1	B2	H0	H1	H2
302.2134.000	130	71,5	100,5	44	56,5	161,4	58,7	102,7

ENERGY EFFICIENCY INDEX

EEI ≤ 0,23 - Part 2

Reference value for the most efficient circulation pump is EEI ≤ 0.20

PERFORMANCE CURVES

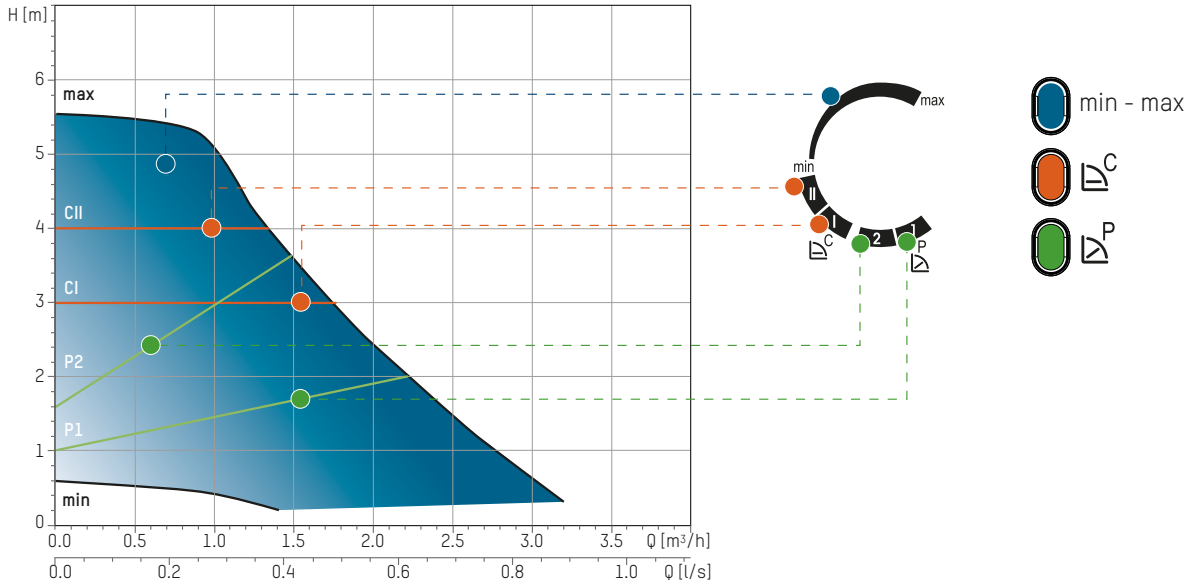

Q [m³/h]	0.4	0.8	1.2	1.6	2	2.4	2.8	3.2
H [m]	5.6	5.5	4.6	3.4	2.5	1.7	0.9	0.4

POWER CONSUMPTION CURVES

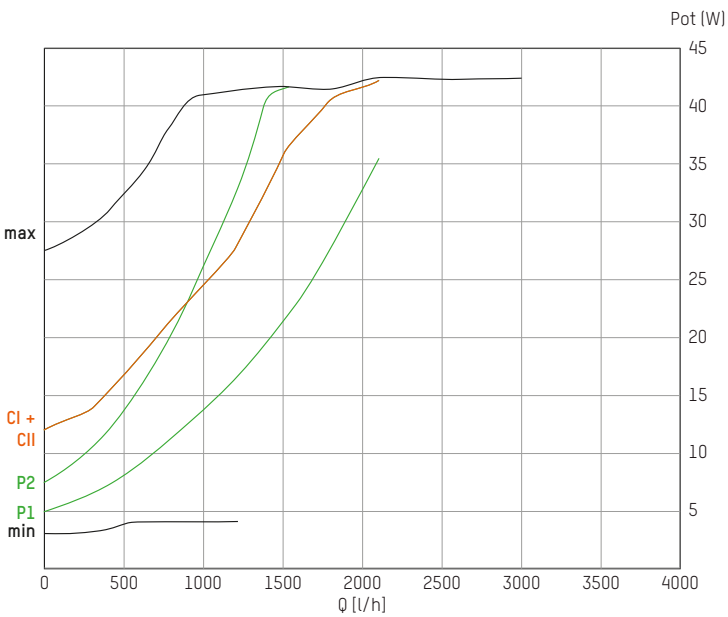

TACOFLOW2 ADAPT

HEATING CIRCUIT PUMPS



Glandless circulator pumps for hot water heating systems in residential and commercial buildings.

DESCRIPTION

The TacoFlow2 ADAPT is driven by permanent-magnet synchronous motors.

These innovative motors achieve a high efficiency at low operating costs.

They are maintenance-free and do not need replacement of seals and gaskets.

INSTALLATION POSITION

The pump can be installed both horizontally or vertically. The arrow indicating the medium's flow direction must be observed.

ADVANTAGES

- activeADAPT function: Automatic adaptation of the pump rate to the specific requirements of the system
- Efficient throughput setting with variable Δp -v proportional pressure curves, constant-pressure curves Δp -c or fixed Min-Max speed
- Media temperature range from +2°C to +110°C
- Insulation shell supplied as standard
- A colour LED indicates the current operating state
- 5 year guarantee

OPERATION

The circulation pump are of a glandless design, since the rotating parts of the motor run inside the pumped medium. This provides lubrication for the motor and the rotating parts. The circulation pump is equipped with anti-blocking protection, since the high efficiency pumps no longer have a pump head screw for manual unblocking. They also feature an automatic venting function, which detects and indicates any air in the pump.

BUILDING CATEGORIES

- Apartment blocks, single family dwellings, housing estates, multiple dwelling units
- Smaller public buildings
- Hotels and restaurants, industrial kitchens
- School buildings and sports facilities
- Office, commercial and industrial buildings
- Facilities with partial use, such as barracks, camping sites

SYSTEM/BASIC DIAGRAM

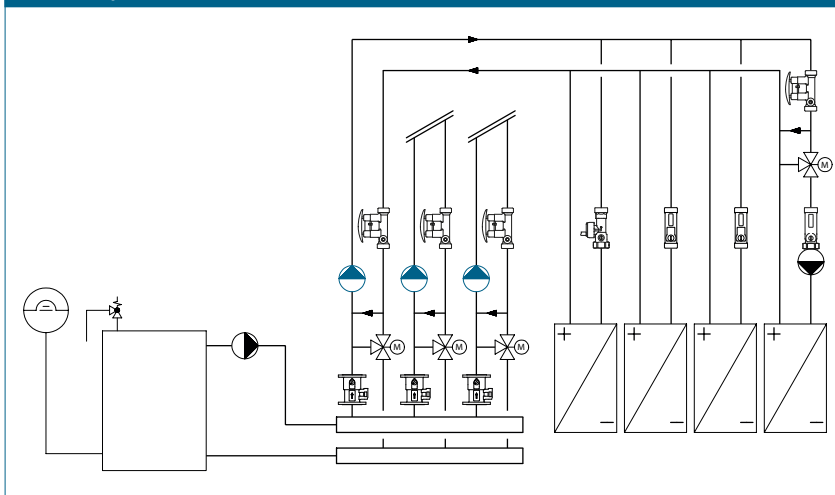

SPECIFICATION TEXT

See www.taconova.com

TECHNICAL DATA

Pump

- Ambient temperature: +0 °C to +40 °C
- Permissible temperature range*: +2 °C to +110 °C
- Permissible temperature ranges at max. ambient temperature:
 - at 30 °C: +30 °C to +110 °C
 - at 35 °C: +35 °C to +90 °C
 - at 40 °C: +40 °C to +70 °C
- Static pressure: Max. 1.0 MPa - 10 bar
- Minimum pressure at air intake:
 - 0.03 MPa (0.3 bar) at 50 °C
 - 0.10 MPa (1.0 bar) at 95 °C
 - 0.15 MPa (1.5 bar) at 110 °C
- Max. relative humidity: ≤ 95%
- Sound pressure level: <43 dB (A)
- Low Voltage Directive (2006/95/EC): Standards applied: EN 62233, EN 60335-1 and EN 60335-2-51
- EMC Directive (2004/108/EC); Standards applied: EN 61000-3-2, EN 61000-3-3, EN 55014-1 and EN 55014-2
- Ecodesign Directive (2009/125/EC); Standards applied: EN 16297-1 and EN 16297-2

Material

- Pump body: Cast iron, CDP-coated (EN-GJL-200)
- Impeller: Composite plastic
- Shaft: Ceramic
- Bearing: Graphite
- Axial thrust bearing: Ceramic
- Can: Composite plastic

* To prevent condensate in the motor and on the control electronics, the temperature of the pumped medium must always be higher than the ambient temperature.

TECHNICAL DATA (CONTINUED)

Motor and electronics

- Supply voltage: 1x230 V (±10%); frequency: 50/60 Hz
- Pump power plug
- Power rating (P1): Min. 3 W, max. 42 W
- Rated current (I1): Min. 0.03 A, max. 0.33 A
- Insulation class: H
- Protection rating: IP 44
- Safety category: II

TECHNICAL DATA (CONTINUED)

Fluids

- Heating water (VDI 2035; SWKI BT 102-01; ÖNORM H 5195-1)
- Water and proprietary additives used against corrosion and freezing up to 30 %

TYPE OVERVIEW

TacoFlow2 ADAPT | Heating circuit pumps

Cast iron high efficiency pump with plug connection and activeADAPT function. Standard thermal insulation shell.

Pump head: 6 m

Order no.	Designation	Connection	Centre distance	Weight
302.2232.000	ADAPT 15-60/130	G 1"	130 mm	1,67 kg
302.4232.000	ADAPT 25-60/130	G 1 ½"	130 mm	1,81 kg
302.5232.000	ADAPT 25-60/180	G 1 ½"	180 mm	1,96 kg
302.6232.000	ADAPT 32-60/180	G 2"	180 mm	2,10 kg

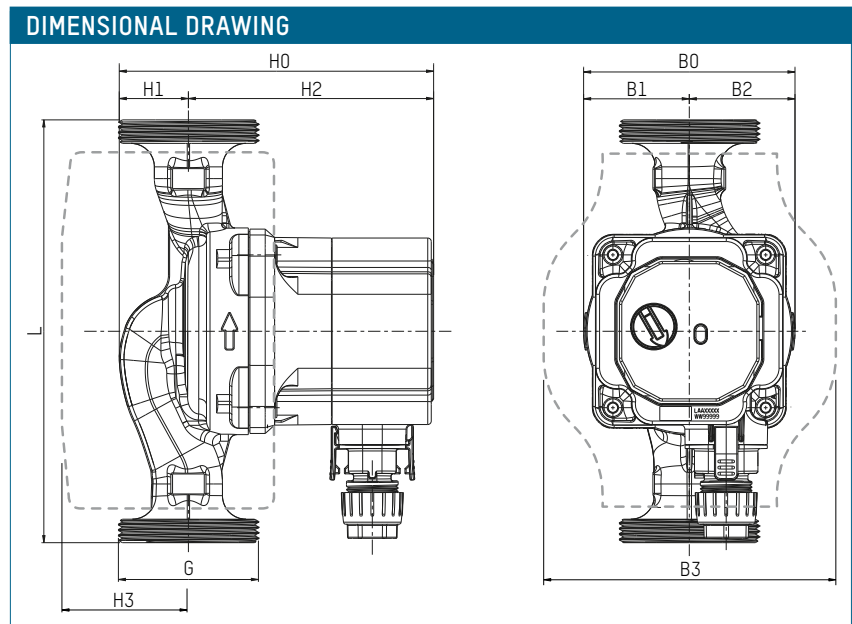

MEASUREMENT TABLE

Order no.	L	B0	B1	B2	B3	H0	H1	H2	H3
302.2232.000	130	90	45	45	124	133,8	29,4	104,4	49
302.4232.000	130	90	45	45	124	133,8	29,4	104,4	49
302.5232.000	180	90	45	45	124	133,8	29,4	104,4	49
302.6232.000	180	90	45	45	124	133,8	29,4	104,4	49

ENERGY EFFICIENCY INDEX

EEI ≤ 0,20 - Part 2

Reference value for the most efficient circulation pump is EEI ≤ 0.20

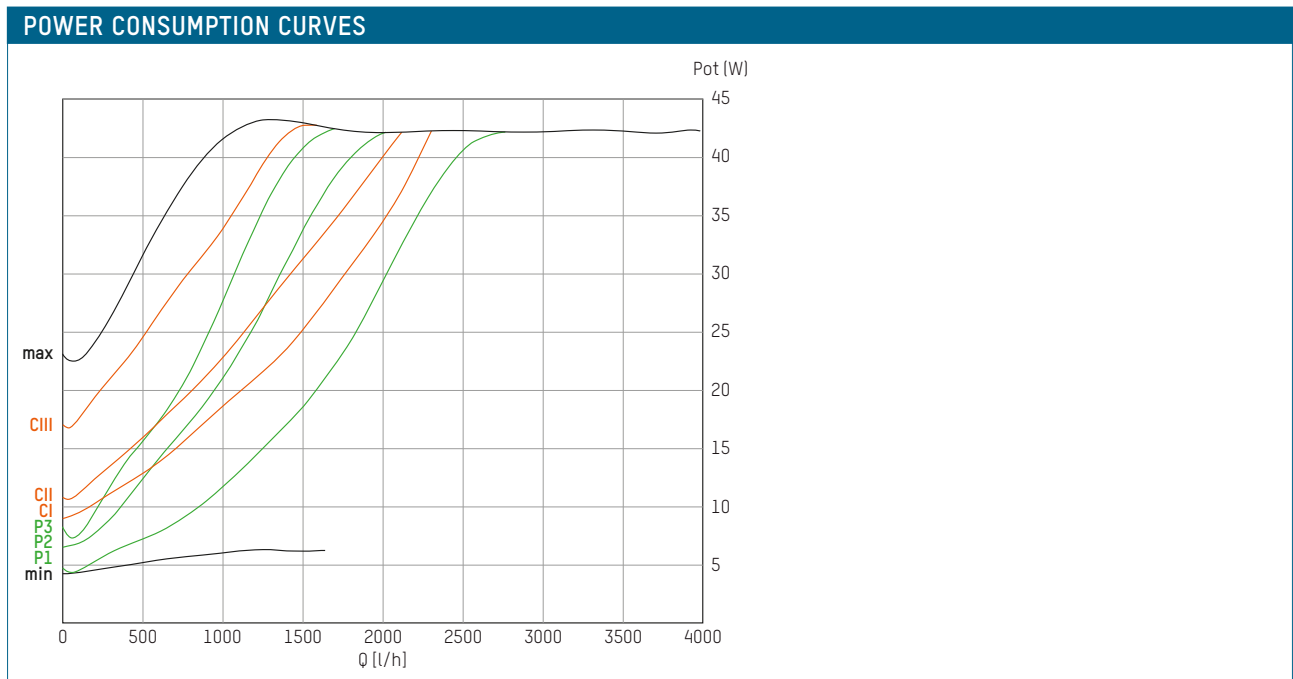
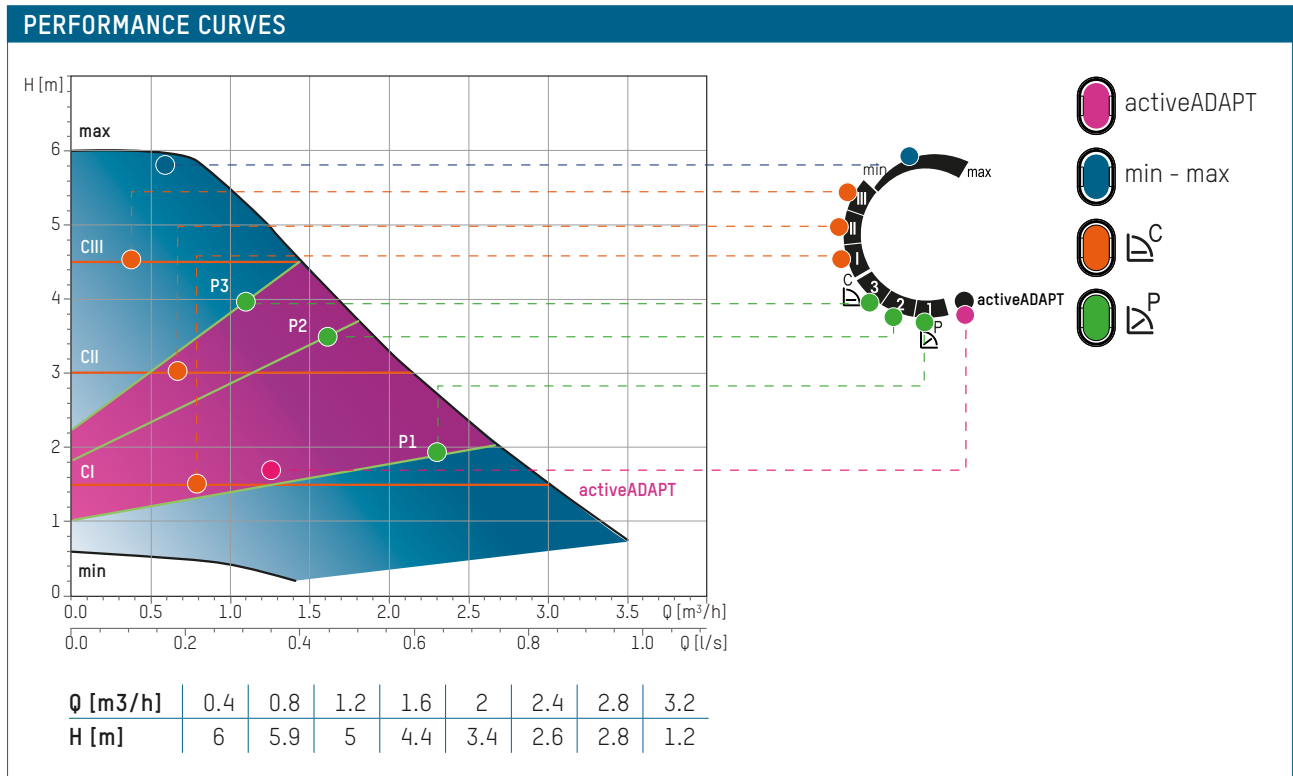

SPECIFICATION TEXT

See www.taconova.com

TECHNICAL DATA

Pump

- Ambient temperature: +0 °C to +40 °C
- Permissible temperature range*: +2 °C to +110 °C
- Permissible temperature ranges at max. ambient temperature:
 - at 30 °C: +30 °C to +110 °C
 - at 35 °C: +35 °C to +90 °C
 - at 40 °C: +40 °C to +70 °C
- Static pressure: Max. 1.0 MPa - 10 bar
- Minimum pressure at air intake:
 - 0.03 MPa (0.3 bar) at 50 °C
 - 0.10 MPa (1.0 bar) at 95 °C
 - 0.15 MPa (1.5 bar) at 110 °C
- Max. relative humidity: ≤ 95%
- Sound pressure level: <43 dB (A)
- Low Voltage Directive (2006/95/EC): Standards applied: EN 62233, EN 60335-1 and EN 60335-2-51
- EMC Directive (2004/108/EC); Standards applied: EN 61000-3-2, EN 61000-3-3, EN 55014-1 and EN 55014-2
- Ecodesign Directive (2009/125/EC); Standards applied: EN 16297-1 and EN 16297-2

Material

- Pump body: Cast iron, CDP-coated (EN-GJL-200)
- Impeller: Composite plastic
- Shaft: Ceramic
- Bearing: Graphite
- Axial thrust bearing: Ceramic
- Can: Composite plastic

* To prevent condensate in the motor and on the control electronics, the temperature of the pumped medium must always be higher than the ambient temperature.

TECHNICAL DATA (CONTINUED)

Motor and electronics

- Supply voltage: 1x230 V (±10%); frequency: 50/60 Hz
- Pump power plug
- Power rating (P1): Min. 3 W, max. 56 W
- Rated current (I1): Min. 0.03 A, max. 0.44 A
- Insulation class: H
- Protection rating: IP 44
- Safety category: II

TECHNICAL DATA (CONTINUED)

Fluids

- Heating water (VDI 2035; SWKI BT 102-01; ÖNORM H 5195-1)
- Water and proprietary additives used against corrosion and freezing up to 30 %

TYPE OVERVIEW

TacoFlow2 ADAPT | Heating circuit pumps

Cast iron high efficiency pump with plug connection and activeADAPT function. Standard thermal insulation shell.

Pump head: 7 m

Order no.	Designation	Connection	Centre distance	Weight
302.2242.000	ADAPT 15-70/130	G 1"	130 mm	1,91 kg
302.4242.000	ADAPT 25-70/130	G 1 ½"	130 mm	2,05 kg
302.5242.000	ADAPT 25-70/180	G 1 ½"	180 mm	2,20 kg
302.6242.000	ADAPT 32-70/180	G 2"	180 mm	2,34 kg

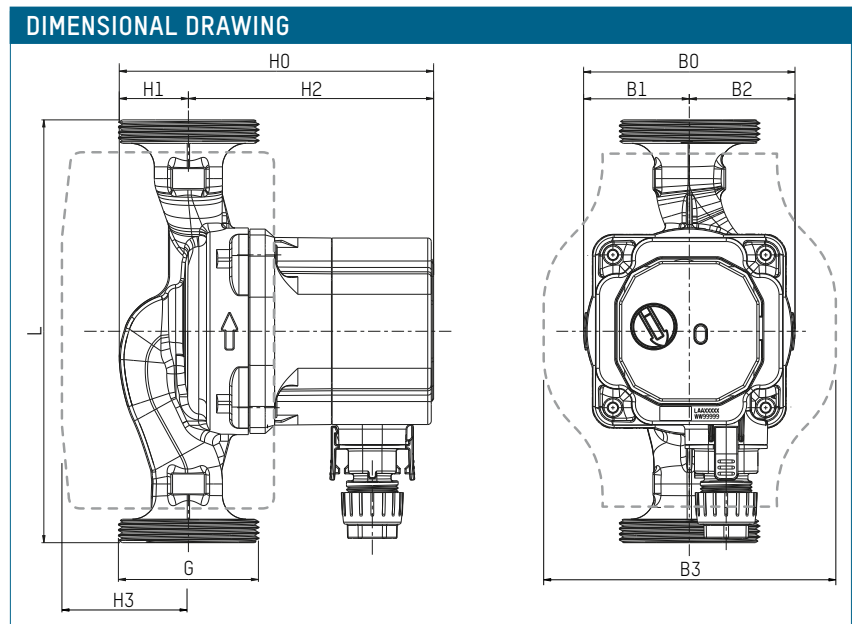

MEASUREMENT TABLE

Order no.	L	B0	B1	B2	B3	H0	H1	H2	H3
302.2242.000	130	90	45	45	124	143,8	29,4	114,4	49
302.4242.000	130	90	45	45	124	143,8	29,4	114,4	49
302.5242.000	180	90	45	45	124	143,8	29,4	114,4	49
302.6242.000	180	90	45	45	124	143,8	29,4	114,4	49

ENERGY EFFICIENCY INDEX

EEI ≤ 0,21 - Part 2

Reference value for the most efficient circulation pump is EEI ≤ 0.20

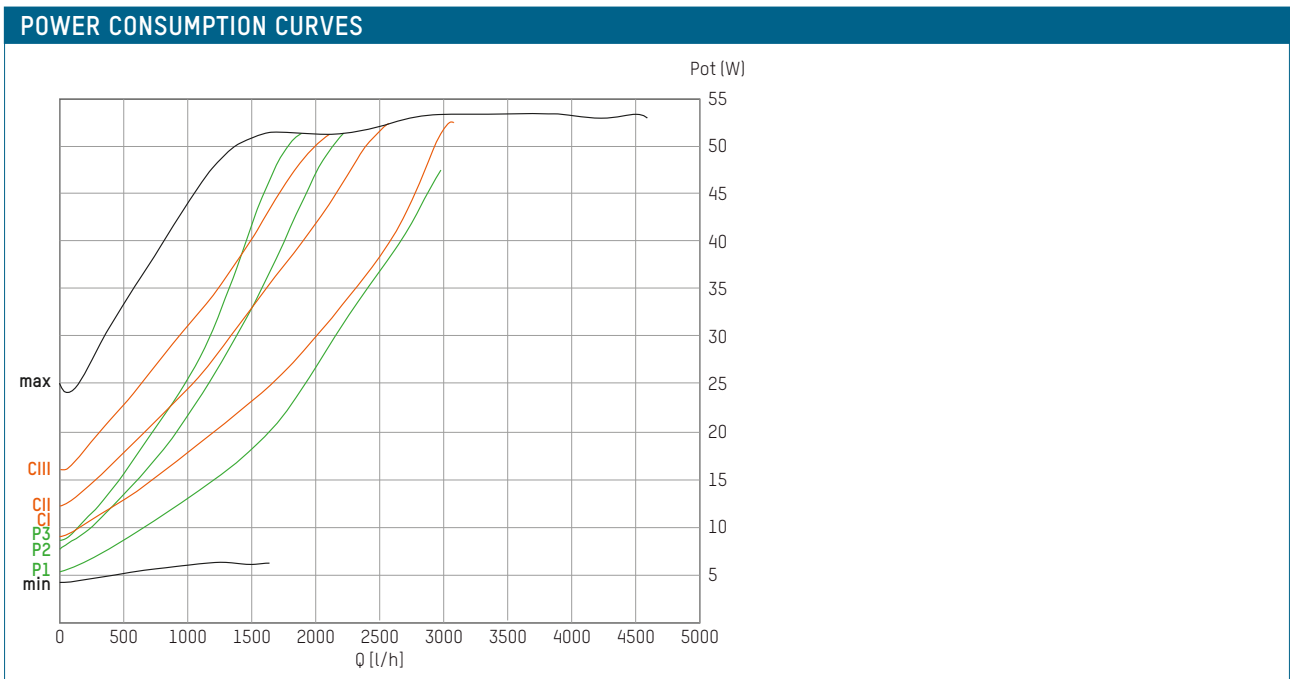
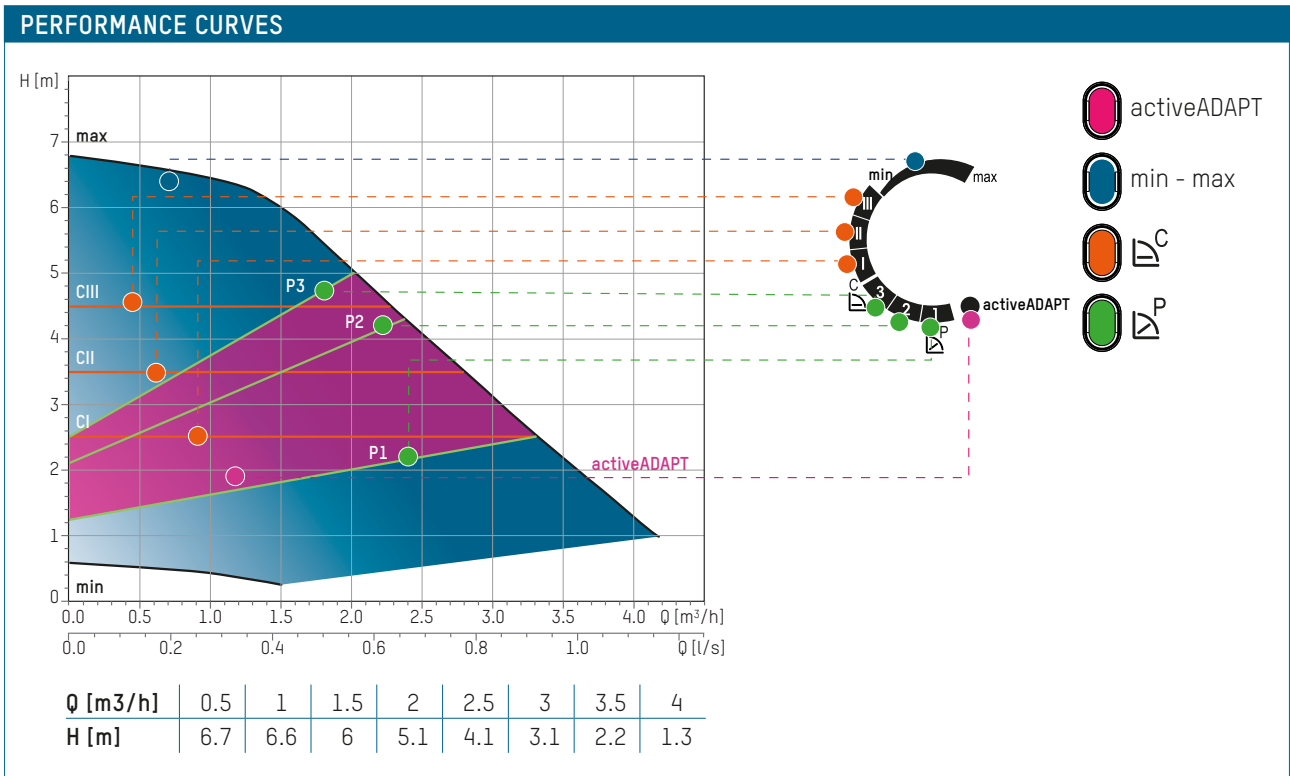

TACOFLOW2 ELINK

HEATING CIRCUIT PUMPS



Glandless circulator pumps for hot water heating systems in residential and commercial buildings.

DESCRIPTION

The TacoFlow2 eLink is driven by permanent-magnet synchronous motors.

These innovative motors achieve a high efficiency at low operating costs.

They are maintenance-free and do not need replacement of seals and gaskets.

INSTALLATION POSITION

The pump can be installed both horizontally or vertically. The arrow indicating the medium's flow direction must be observed.

ADVANTAGES

- eLink: Wireless communication between circulation pump and smartphone/tablet
- Additional, finer adjustment options
- Technical information shown on the display
- Efficient output setting through activeADAPT function, variable Δp -v proportional pressure curve, constant pressure curve Δp -c or fixed min./max. speed
- Insulation shell supplied as standard
- A colour LED indicates the current operating state
- 5 year guarantee

OPERATION

The circulation pump are of a glandless design, since the rotating parts of the motor run inside the pumped medium. This provides lubrication for the motor and the rotating parts. The circulation pump is equipped with anti-blocking protection, since the high efficiency pumps no longer have a pump head screw for manual unblocking. They also feature an automatic venting function, which detects and indicates any air in the pump.

WITH THE NEW TACOFLOW2 ELINK APP YOU HAVE EVERYTHING IN VIEW, EVERYTHING UNDER CONTROL.

Control, check, categorise, log, save, email and much more. Wirelessly and intuitive to use via smartphone and tablet. The new Taconova eLink app for smartphone and tablet communicates with the respective, newly developed pump, to allow the finest adjustment options while providing all relevant information regarding its operation.



BUILDING CATEGORIES

- Apartment blocks, single family dwellings, housing estates, multiple dwelling units
- Smaller public buildings
- Hotels and restaurants, industrial kitchens
- School buildings and sports facilities
- Office, commercial and industrial buildings
- Facilities with partial use, such as barracks, camping sites

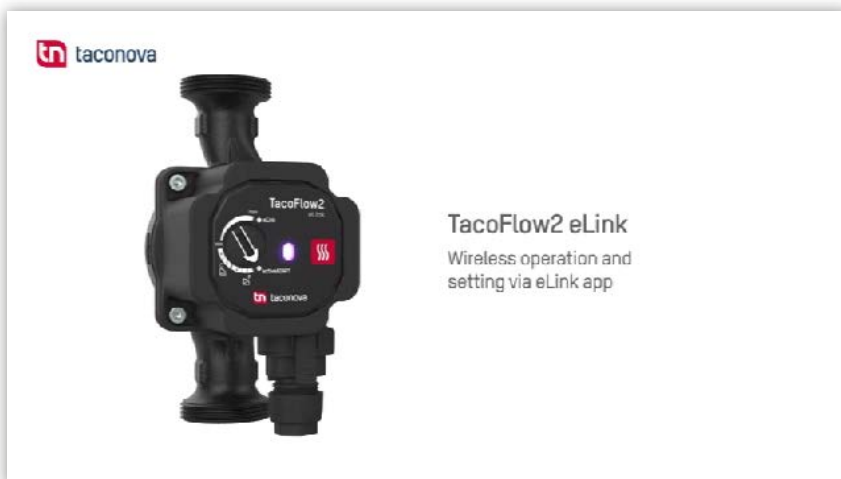

SPECIFICATION TEXT

See www.taconova.com

TECHNICAL DATA

Pump

- Ambient temperature: +0 °C to +40 °C
- Permissible temperature range*: +2 °C to +110 °C
- Permissible temperature ranges at max. ambient temperature:
 - at 30 °C: +30 °C to +110 °C
 - at 35 °C: +35 °C to +90 °C
 - at 40 °C: +40 °C to +70 °C
- Static pressure: Max. 1.0 MPa - 10 bar
- Minimum pressure at air intake:
 - 0.03 MPa (0.3 bar) at 50 °C
 - 0.10 MPa (1.0 bar) at 95 °C
 - 0.15 MPa (1.5 bar) at 110 °C
- Max. relative humidity: ≤ 95%
- Sound pressure level: <43 dB (A)
- Low Voltage Directive (2006/95/EC): Standards applied: EN 62233, EN 60335-1 and EN 60335-2-51
- EMC Directive (2004/108/EC); Standards applied: EN 61000-3-2, EN 61000-3-3, EN 55014-1 and EN 55014-2
- Ecodesign Directive (2009/125/EC); Standards applied: EN 16297-1 and EN 16297-2

Material

- Pump body: Cast iron, CDP-coated (EN-GJL-200)
- Impeller: Composite plastic
- Shaft: Ceramic
- Bearing: Graphite
- Axial thrust bearing: Ceramic
- Can: Composite plastic

* To prevent condensate in the motor and on the control electronics, the temperature of the pumped medium must always be higher than the ambient temperature.

TECHNICAL DATA (CONTINUED)

Motor and electronics

- Supply voltage: 1x230 V (±10%); frequency: 50/60 Hz
- Pump power plug
- Power rating (P1): Min. 3 W, max. 42 W
- Rated current (I1): Min. 0.03 A, max. 0.33 A
- Insulation class: H
- Protection rating: IP 44
- Safety category: II

TECHNICAL DATA (CONTINUED)

Fluids

- Heating water (VDI 2035; SWKI BT 102-01; ÖNORM H 5195-1)
- Water and proprietary additives used against corrosion and freezing up to 30 %

TYPE OVERVIEW

TacoFlow2 eLink | Heating circuit pumps

Cast iron high efficiency pump with plug connection, activeADAPT and eLink function. Standard thermal insulation shell.

Pump head: 6 m

Order no.	Designation	Connection	Centre distance	Weight
302.4233.000	eLink 25-60/130	G 1 ½"	130 mm	1,81 kg
302.5233.000	eLink 25-60/180	G 1 ½"	180 mm	1,96 kg
302.6233.000	eLink 32-60/180	G 2"	180 mm	2,10 kg

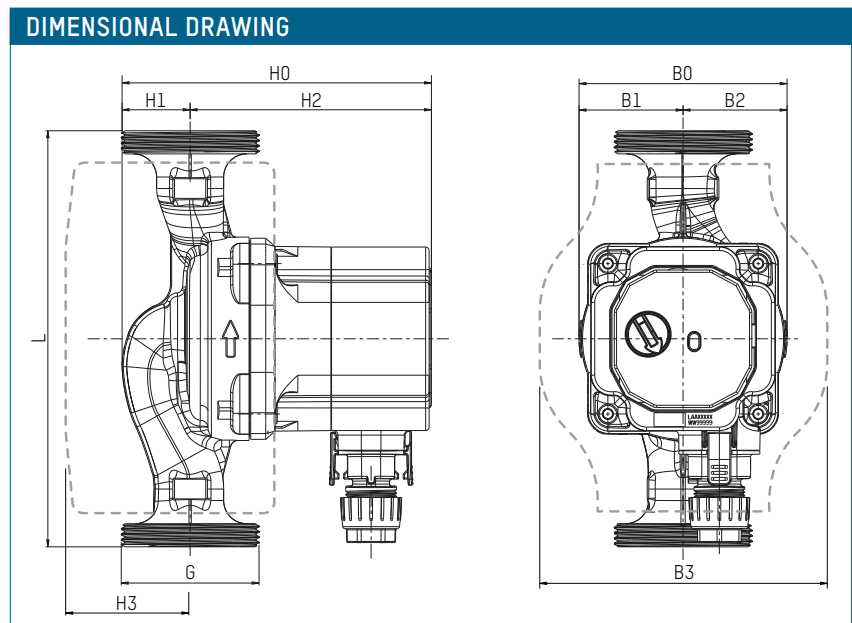

MEASUREMENT TABLE

Order no.	L	B0	B1	B2	B3	H0	H1	H2	H3
302.4233.000	130	90	45	45	124	133,8	29,4	104,4	49
302.5233.000	180	90	45	45	124	133,8	29,4	104,4	49
302.6233.000	180	90	45	45	124	133,8	29,4	104,4	49

ENERGY EFFICIENCY INDEX

EEI ≤ 0,20 - Part 2

Reference value for the most efficient circulation pump is EEI ≤ 0.20

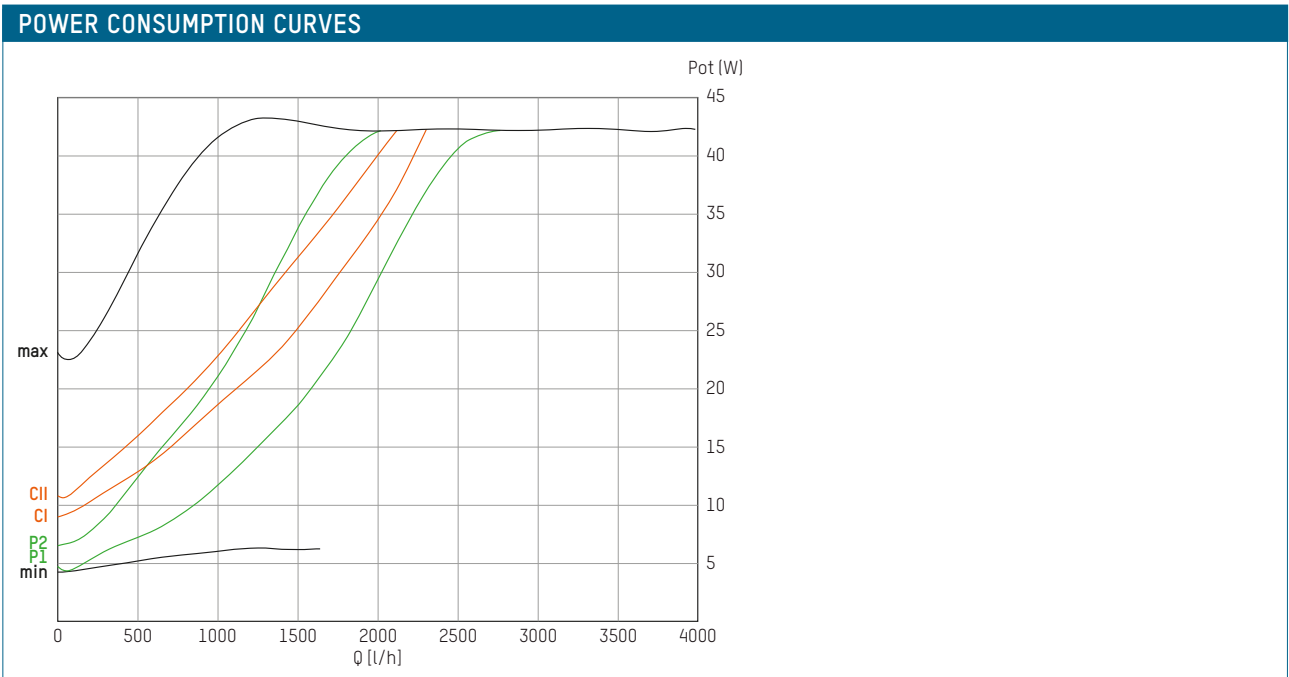
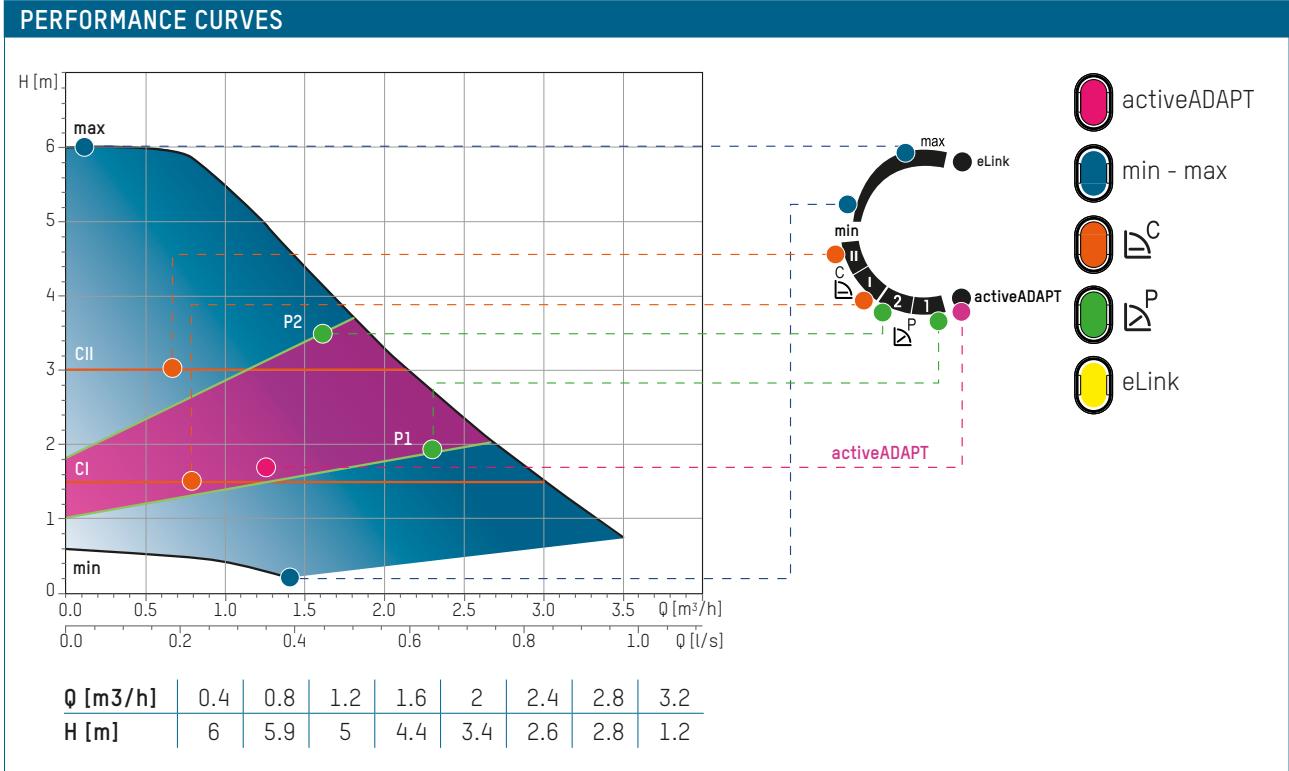

TACOFLOW3 MAX

HEATING AND COOLING CIRCUIT PUMPS



Glandless circulator pumps for hot water heating systems in residential and commercial buildings.

DESCRIPTION

The TacoFlow3 MAX is driven by permanent-magnet synchronous motors.

These innovative motors achieve a high efficiency at low operating costs.

They are maintenance-free and do not need replacement of seals and gaskets.

INSTALLATION POSITION

The pump can be installed both horizontally or vertically.

The arrow indicating the medium's flow direction must be observed.

ADVANTAGES

- activeADAPT function: Automatic adaptation of the pump rate to the specific requirements of the system
- Efficient output setting with variable $\Delta p-v$ proportional pressure curve, constant pressure curves $\Delta p-c$, fixed min./max. speed and 0-10 V or PWM control
- Media temperature range from -10°C to $+110^{\circ}\text{C}$
- Insulation shell supplied as standard
- A colour LED indicates the current operating state

OPERATION

The circulation pump are of a glandless design, since the rotating parts of the motor run inside the pumped medium. This provides lubrication for the motor and the rotating parts. The circulation pump is equipped with anti-blocking protection, since the high efficiency pumps no longer have a pump head screw for manual unblocking. They also feature an automatic venting function, which detects and indicates any air in the pump.

BUILDING CATEGORIES

- Apartment blocks, multiple dwelling units
- Public buildings
- Hotels and restaurants, industrial kitchens
- School buildings and sports facilities
- Office, commercial and industrial buildings
- Facilities with partial use, such as barracks, camping sites

SYSTEM/BASIC DIAGRAM

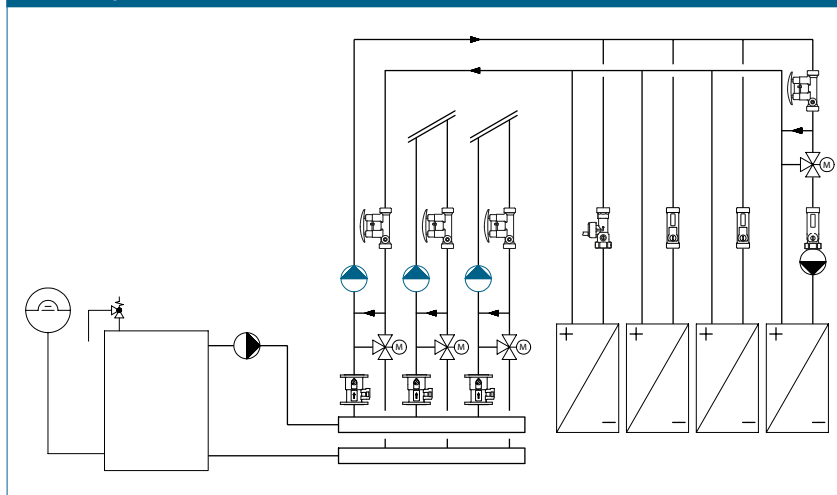

SPECIFICATION TEXT

See www.taconova.com

TECHNICAL DATA

Pump

- Ambient temperature: +0 °C to +40 °C
- Permissible temperature range: -10 °C to +110 °C
- Permissible temperature ranges at max. ambient temperature:
 - at 30 °C: +30 °C to +100 °C
 - at 40 °C: +40 °C to +70 °C
- Static pressure: Max. 1.0 MPa - 10 bar
- Minimum pressure at air intake:
 - 0.05 MPa (0.5 bar) at 80 °C
 - 0.15 MPa (1.5 bar) at 95 °C
- Max. relative humidity: ≤ 80%
- Sound pressure level: < 43 dB (A)
- Low Voltage Directive (2006/95/EC): Standards applied: EN 60335-1 and EN 60335-2-51
- EMC Directive (2004/108/EC); Standards applied: EN 61000-3-2, EN 61000-3-3
- Ecodesign Directive (2009/125/EC); Standards applied: EN 16297-1, EN 16297-2
- Inputs/outputs: PWM, 0-10 V DC

Material

- Pump body: Cast iron, CDP-coated (EN-GJL-200)
- Impeller: Brass / Composite plastic
- Shaft: Ceramic
- Bearing: Graphite / Ceramic
- Rotor housing: Composite plastic

TECHNICAL DATA (CONTINUED)

Motor and electronics

- Supply voltage: 1x230 V (±10%), PE frequency: 50/60 Hz
- Power rating (P1): Min. 16 W, max. 88 W
- Rated current (I1): Min. 0.2 A, max. 0.6 A
- Insulation class: F
- Protection rating: IP 44
- Temperature class: TF 110

TECHNICAL DATA (CONTINUED)

Fluids

- Heating water (VDI 2035; SWKI BT 102-01; ÖNORM H 5195-1)
- Water and proprietary additives used against corrosion and freezing up to 30 %

TYPE OVERVIEW

TacoFlow3 MAX | Heating and cooling circuit pumps
 Cast iron high efficiency pump with threaded and plug connection.
 Standard thermal insulation shell.
 Pump head: 6 m

Order no.	Designation	G	Centre distance	Weight
302.5238.000	MAX 25-60/180	1 ½"	180 mm	3.5 kg
302.6238.000	MAX 32-60/180	2"	180 mm	3.5 kg

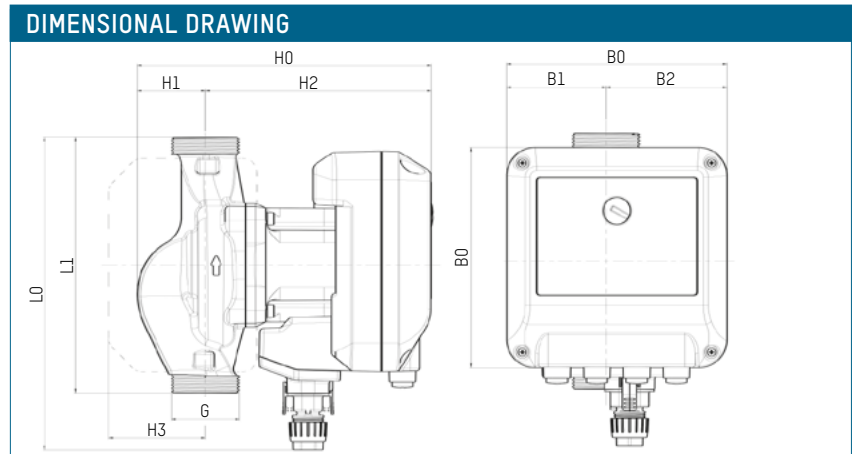

MEASUREMENT TABLE

Order no.	L0	L1	B0	B1	B2	H0	H1	H2	H3
302.5238.000	220	180	155	70	85	207	48	159	68
302.6238.000	220	180	155	70	85	207	48	159	68

ENERGY EFFICIENCY INDEX

EEI ≤ 0,22 - Part 2

Reference value for the most efficient circulation pump is EEI ≤ 0.20

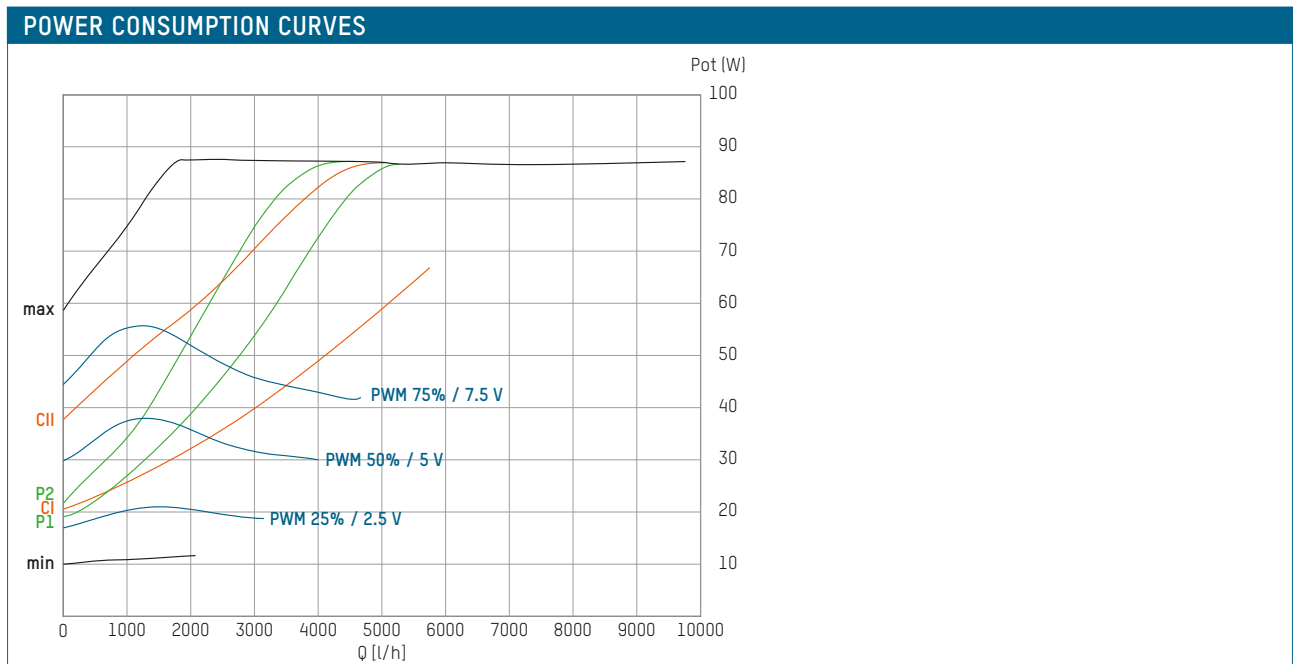
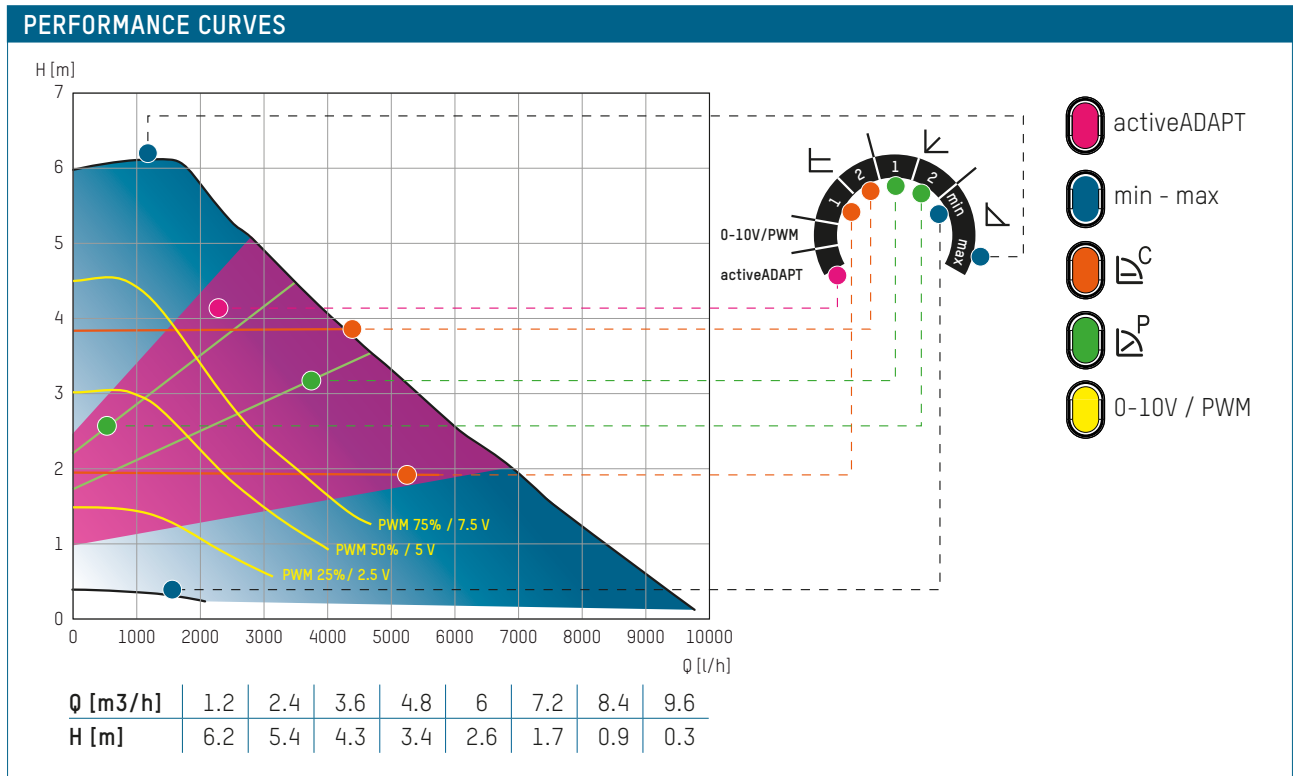

SPECIFICATION TEXT

See www.taconova.com

TECHNICAL DATA

Pump

- Ambient temperature: +0 °C to +40 °C
- Permissible temperature range: -10 °C to +110 °C
- Permissible temperature ranges at max. ambient temperature:
 - at 30 °C: +30 °C to +100 °C
 - at 40 °C: +40 °C to +70 °C
- Static pressure: Max. 1.0 MPa - 10 bar
- Minimum pressure at air intake:
 - 0.05 MPa (0.5 bar) at 80 °C
 - 0.15 MPa (1.5 bar) at 95 °C
- Max. relative humidity: ≤ 80%
- Sound pressure level: < 43 dB (A)
- Low Voltage Directive (2006/95/EC): Standards applied: EN 60335-1 and EN 60335-2-51
- EMC Directive (2004/108/EC); Standards applied: EN 61000-3-2, EN 61000-3-3
- Ecodesign Directive (2009/125/EC); Standards applied: EN 16297-1 and EN 16297-2
- Inputs/outputs: PWM, 0-10 V DC

Material

- Pump body: Cast iron, CDP-coated (EN-GJL-200)
- Impeller: Brass / Composite plastic
- Shaft: Ceramic
- Bearing: Graphite / Ceramic
- Rotor housing: Composite plastic

TECHNICAL DATA (CONTINUED)

Motor and electronics

- Supply voltage: 1x230 V (±10%), PE frequency: 50/60 Hz
- Power rating (P1): Min. 16 W, max. 122 W
- Rated current (I1): Min. 0.2 A, max. 0.8 A
- Insulation class: F
- Protection rating: IP 44
- Temperature class: TF 110

TECHNICAL DATA (CONTINUED)

Fluids

- Heating water (VDI 2035; SWKI BT 102-01; ÖNORM H 5195-1)
- Water and proprietary additives used against corrosion and freezing up to 30 %

TYPE OVERVIEW

TacoFlow3 MAX | Heating and cooling circuit pumps
 Cast iron high efficiency pump with threaded and plug connection.
 Standard thermal insulation shell.
 Pump head: 8 m

Order no.	Designation	G	Centre distance	Weight
302.5258.000	MAX 25-80/180	1 ½"	180 mm	3.5 kg
302.6258.000	MAX 32-80/180	2"	180 mm	3.5 kg

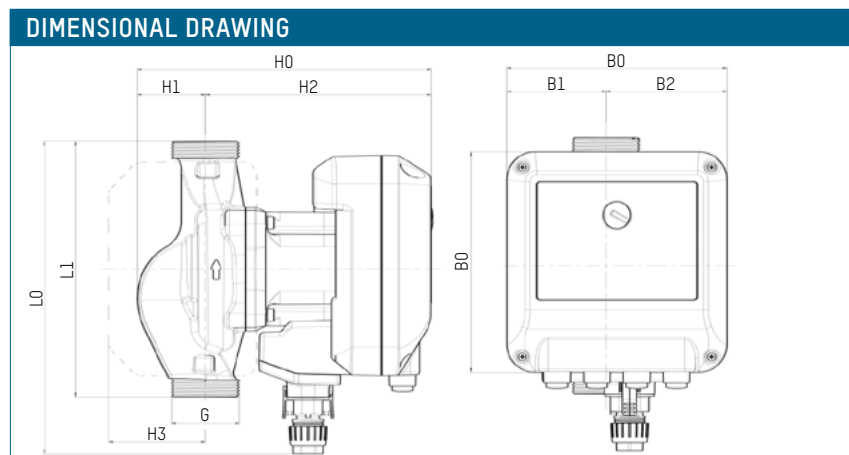

MEASUREMENT TABLE

Order no.	L0	L1	B0	B1	B2	H0	H1	H2	H3
302.5238.000	220	180	155	70	85	207	48	159	68
302.6238.000	220	180	155	70	85	207	48	159	68

ENERGY EFFICIENCY INDEX

EEI ≤ 0,22 - Part 2

Reference value for the most efficient circulation pump is EEI ≤ 0.20

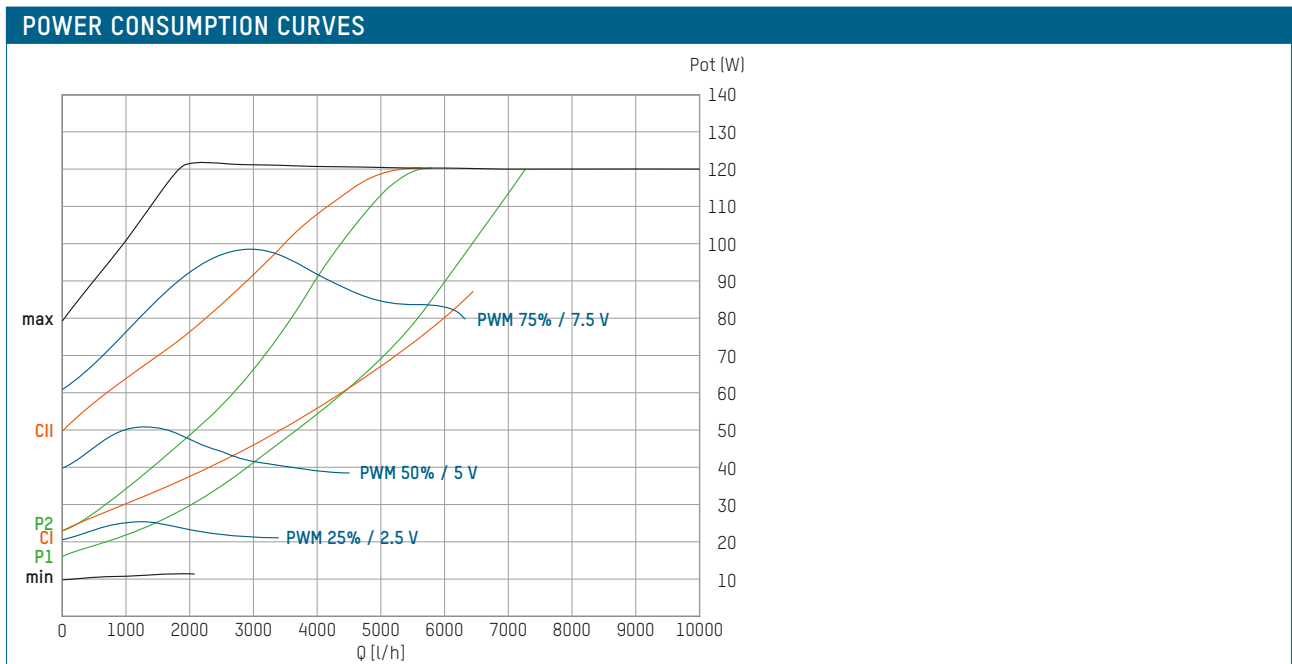
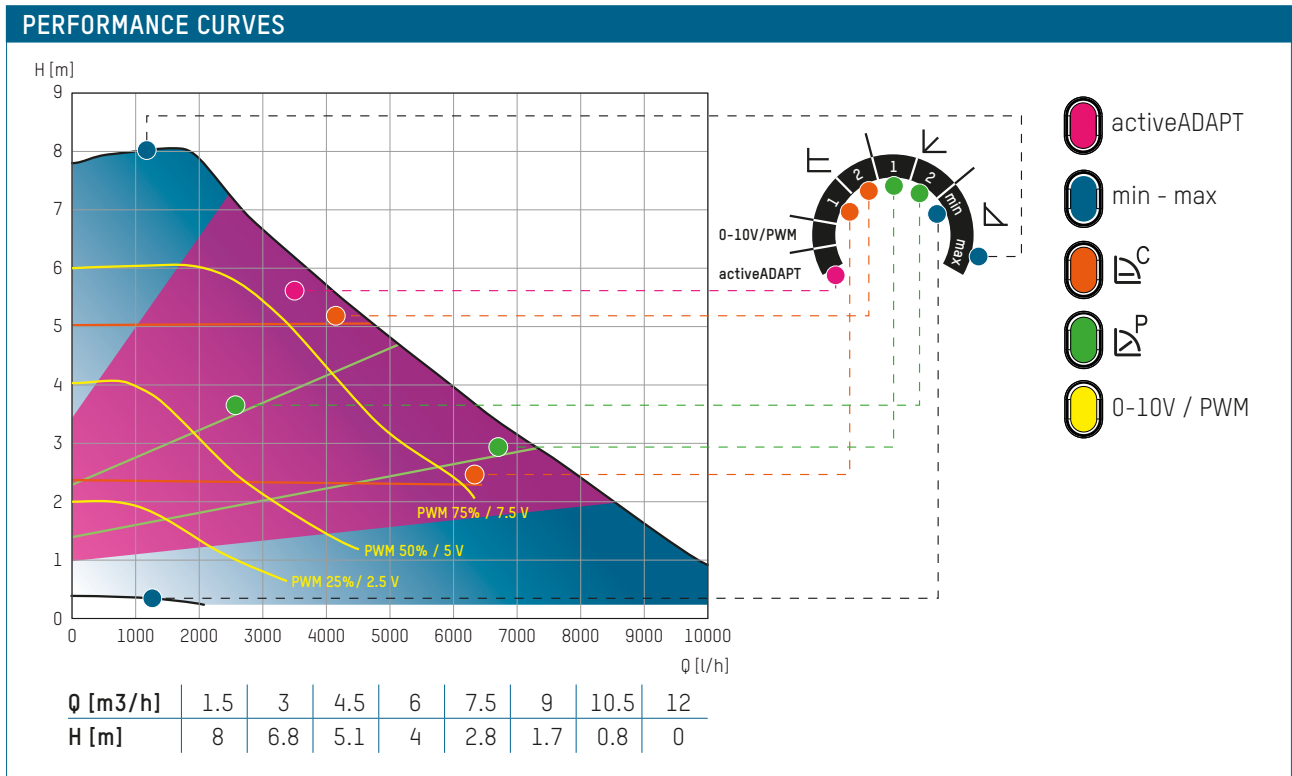

SPECIFICATION TEXT

See www.taconova.com

TECHNICAL DATA

Pump

- Ambient temperature: +0 °C to +40 °C
- Permissible temperature range: -10 °C to +110 °C
- Permissible temperature ranges at max. ambient temperature:
 - at 30 °C: +30 °C to +100 °C
 - at 40 °C: +40 °C to +70 °C
- Static pressure: Max. 1.0 MPa - 10 bar
- Minimum pressure at air intake:
 - 0.05 MPa (0.5 bar) at 80 °C
 - 0.15 MPa (1.5 bar) at 95 °C
- Max. relative humidity: ≤ 80%
- Sound pressure level: < 43 dB (A)
- Low Voltage Directive (2006/95/EC): Standards applied: EN 60335-1 and EN 60335-2-51
- EMC Directive (2004/108/EC); Standards applied: EN 61000-3-2, EN 61000-3-3
- Ecodesign Directive (2009/125/EC); Standards applied: EN 16297-1 and EN 16297-2
- Inputs/outputs: PWM, 0-10 V DC

Material

- Pump body: Cast iron, CDP-coated (EN-GJL-200)
- Impeller: Brass / Composite plastic
- Shaft: Ceramic
- Bearing: Graphite / Ceramic
- Rotor housing: Composite plastic

TECHNICAL DATA (CONTINUED)

Motor and electronics

- Supply voltage: 1x230 V (±10%), PE frequency: 50/60 Hz
- Power rating (P1): Min. 16 W, max. 175 W
- Rated current (I1): Min. 0.2 A, max. 0.9 A
- Insulation class: F
- Protection rating: IP 44
- Temperature class: TF 110

TECHNICAL DATA (CONTINUED)

Fluids

- Heating water (VDI 2035; SWKI BT 102-01; ÖNORM H 5195-1)
- Water and proprietary additives used against corrosion and freezing up to 30 %

TYPE OVERVIEW

TacoFlow3 MAX | Heating and cooling circuit pumps
 Cast iron high efficiency pump with threaded and plug connection.
 Standard thermal insulation shell.
 Pump head: 10 m

Order no.	Designation	G	Centre distance	Weight
302.5268.000	MAX 25-100/180	1 ½"	180 mm	3.5 kg
302.6268.000	MAX 32-100/180	2"	180 mm	3.5 kg

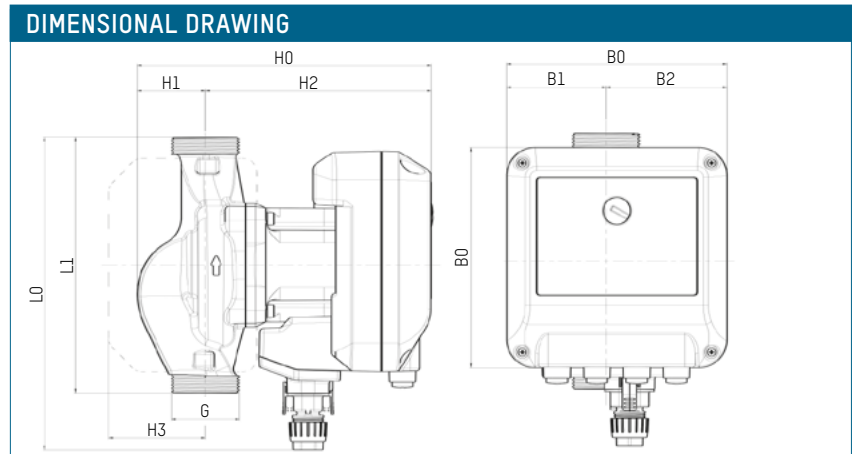

MEASUREMENT TABLE

Order no.	L0	L1	B0	B1	B2	H0	H1	H2	H3
302.5268.000	220	180	155	70	85	207	48	159	68
302.6268.000	220	180	155	70	85	207	48	159	68

ENERGY EFFICIENCY INDEX

EEI ≤ 0,22 - Part 2

Reference value for the most efficient circulation pump is EEI ≤ 0.20

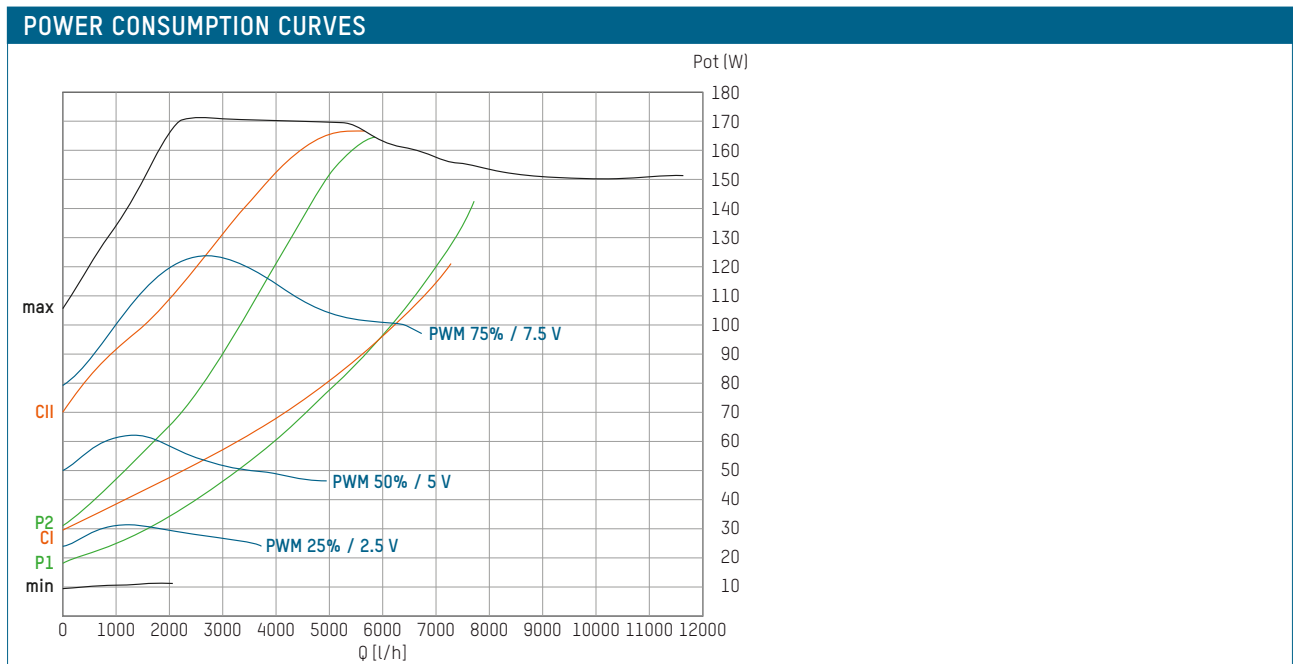
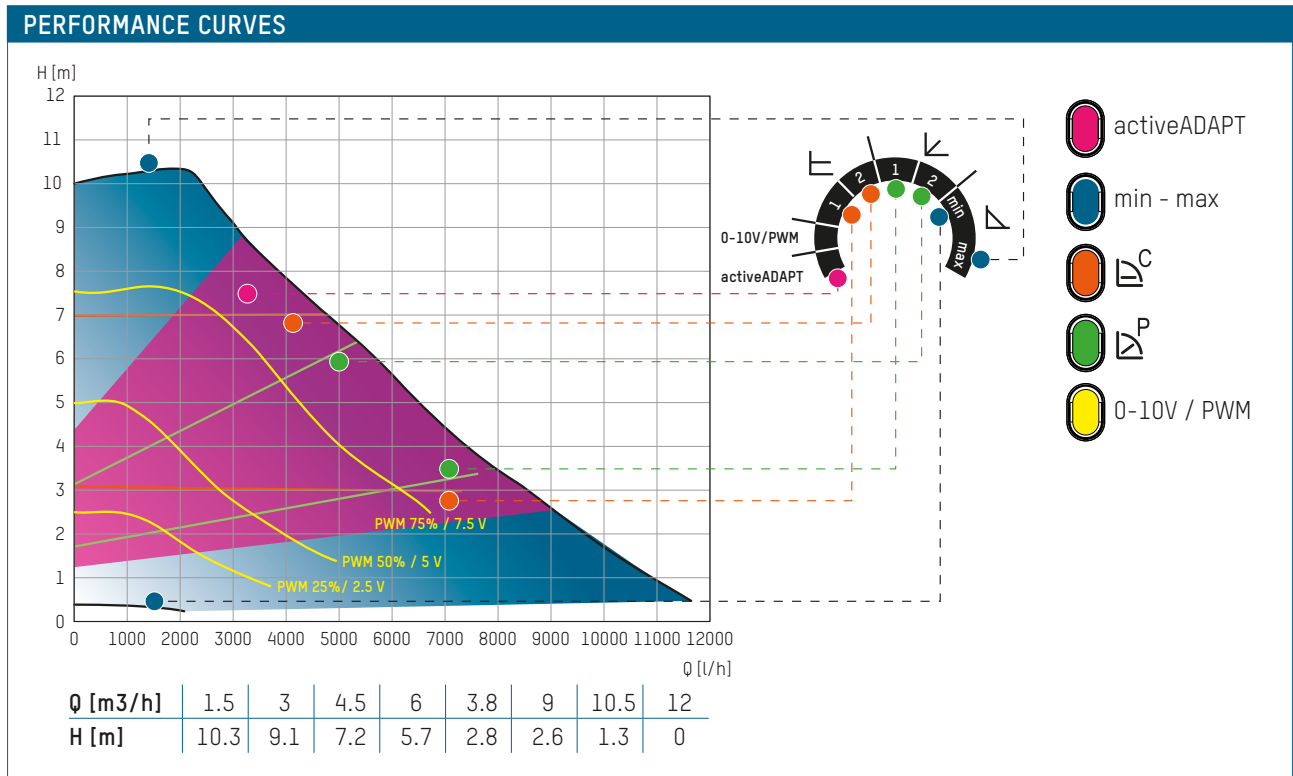

TACOFLOW3 MAX PRO

HEATING AND COOLING CIRCUIT PUMPS



Glandless circulation pumps for hot water heating, air conditioning, cooling, geothermal and solar thermal systems in residential and commercial buildings.

DESCRIPTION

The TacoFlow3 MAX PRO is driven by permanent-magnet synchronous motors.

These innovative motors achieve a high efficiency at low operating costs.

They are maintenance-free and do not need replacement of seals and gaskets.

INSTALLATION POSITION

The pump can be installed both horizontally or vertically.

The arrow indicating the medium's flow direction must be observed.

ADVANTAGES

- Simple setting of the output curves by means of pushbuttons
- With activeADAPT, variable Δp -v proportional pressure curves, constant pressure curves Δp -c, fixed min. - max. speed and 0-10 V or PWM control
- Night setback function
- Holiday function
- Media temperature range from -10 °C to +110 °C
- Thermal insulation shell supplied as standard
- Screen for displaying technical information

OPERATION

The circulation pump are of a glandless design, since the rotating parts of the motor run inside the pumped medium. This provides lubrication for the motor and the rotating parts. The circulation pump is equipped with anti-blocking protection, since the high efficiency pumps no longer have a pump head screw for manual unblocking. They also feature an automatic venting function, which detects and indicates any air in the pump.

BUILDING CATEGORIES

- Apartment blocks
- Public buildings
- Hotels and restaurants, industrial kitchens
- School buildings and sports facilities
- Office, commercial and industrial buildings
- Facilities with partial use, such as barracks, camping sites

SYSTEM/BASIC DIAGRAM

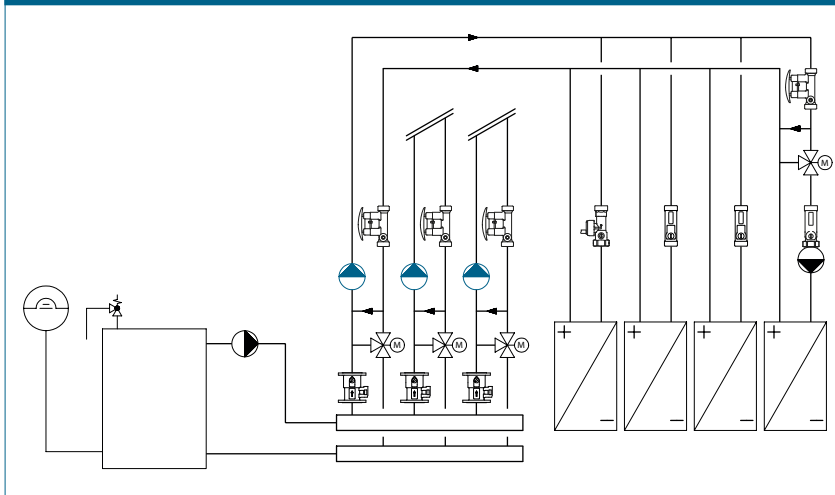

SPECIFICATION TEXT

See www.taconova.com

TECHNICAL DATA

Pump

- Ambient temperature: +0 °C to +40 °C
- Permissible temperature range: -10 °C to +110 °C
- Permissible temperature ranges at max. ambient temperature:
 - at 30 °C: +30 °C to +100 °C
 - at 40 °C: +40 °C to +70 °C
- Static pressure: Max. 1.0 MPa - 10 bar
- Minimum pressure at air intake:
 - 0.05 MPa (0.5 bar) at 80 °C
 - 0.15 MPa (1.5 bar) at 95 °C
- Max. relative humidity: ≤ 80%
- Sound pressure level: < 43 dB (A)
- Low Voltage Directive (2006/95/EC): Standards applied: EN 60335-1 and EN 60335-2-51
- EMC Directive (2004/108/EC); Standards applied: EN 61000-3-2, EN 61000-3-3
- Ecodesign Directive (2009/125/EC); Standards applied: EN 16297-1 and EN 16297-2
- Inputs/outputs: PWM, 0-10 V DC

Material

- Pump body: Cast iron, CDP-coated (EN-GJL-200)
- Impeller: Brass / Composite plastic
- Shaft: Ceramic
- Bearing: Graphite / Ceramic
- Rotor housing: Composite plastic

TECHNICAL DATA (CONTINUED)

Motor and electronics

- Supply voltage: 1x230 V (±10%), PE frequency: 50/60 Hz
- Power rating (P1): Min. 16 W, max. 88 W
- Rated current (I1): Min. 0.2 A, max. 0.6 A
- Insulation class: F
- Protection rating: IP 44
- Temperature class: TF 110

TECHNICAL DATA (CONTINUED)

Fluids

- Heating water (VDI 2035; SWKI BT 102-01; ÖNORM H 5195-1)
- Water and proprietary additives used against corrosion and freezing up to 30 %

TYPE OVERVIEW

TacoFlow3 MAX PRO | Heating and cooling circuit pumps
 Cast iron high efficiency pump with threaded and plug connection.
 Standard thermal insulation shell.
 Pump head: 6 m

Order no.	Designation	G	Centre distance	Weight
302.5239.000	MAX PRO 25-60/180	1 ½"	180 mm	3.5 kg
302.6239.000	MAX PRO 32-60/180	2"	180 mm	3.5 kg

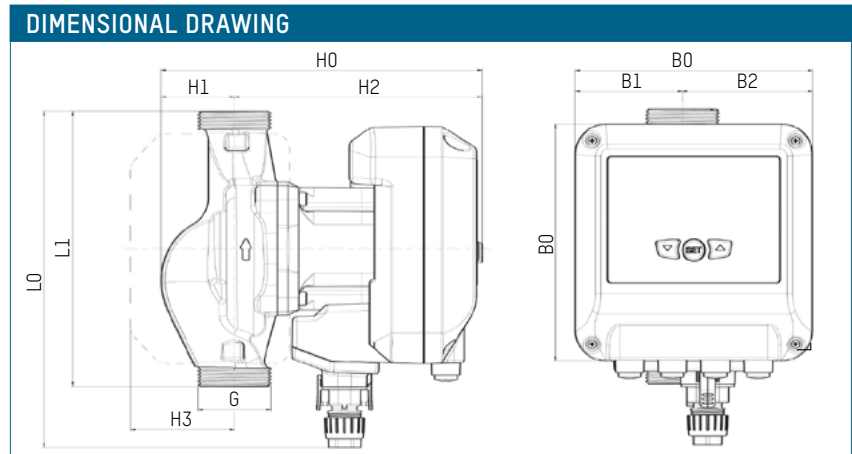

MEASUREMENT TABLE

Order no.	L0	L1	B0	B1	B2	H0	H1	H2	H3
302.5239.000	220	180	155	70	85	207	48	159	68
302.6239.000	220	180	155	70	85	207	48	159	68

ENERGY EFFICIENCY INDEX

EEI ≤ 0,22 - Part 2

Reference value for the most efficient circulation pump is EEI ≤ 0.20

PERFORMANCE CURVES

Operating mode C (Δp -c) – constant differential pressure

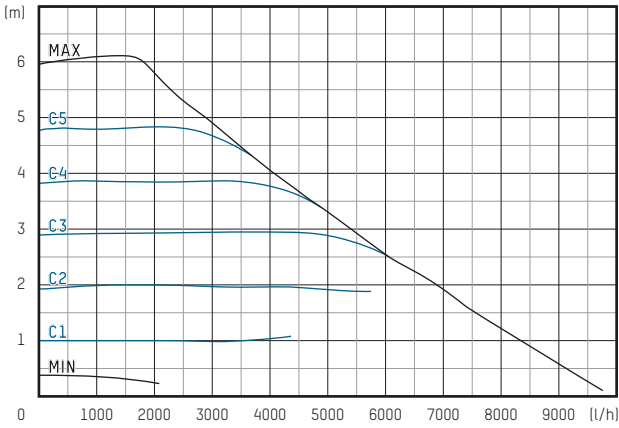

Operating mode P (Δp -v) – variable differential pressure

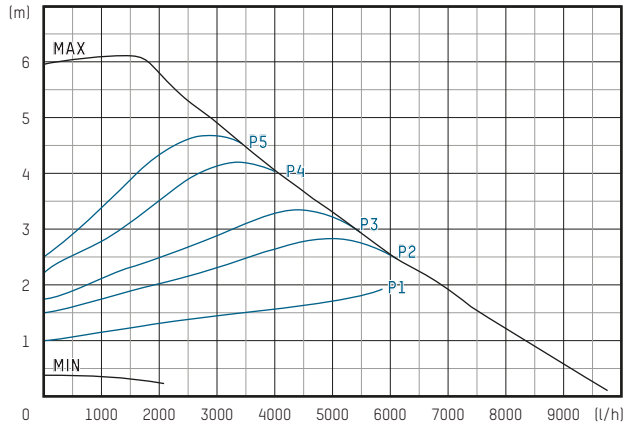

Operating mode activeADAPT - dynamic differential pressure

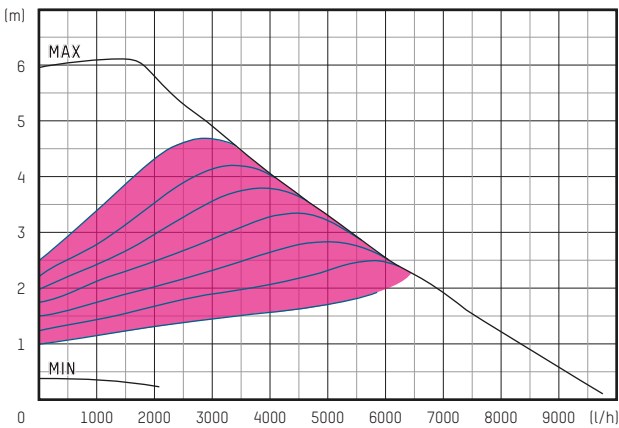

Operating mode 0 – 10 V

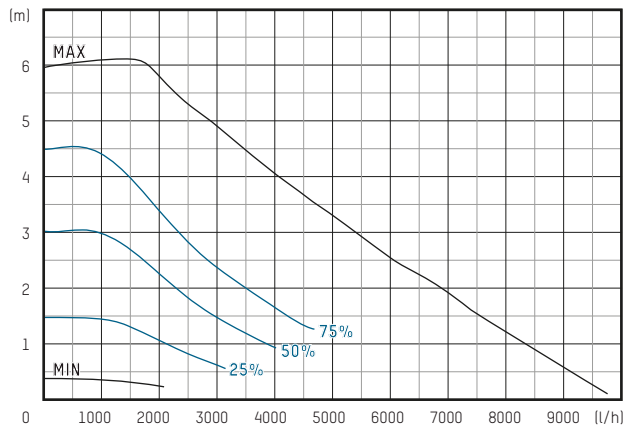

POWER CONSUMPTION CURVES

Operating mode C (Δp -c) – constant differential pressure

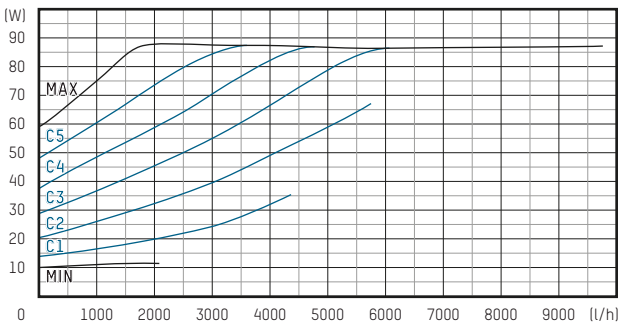

Operating mode P (Δp -v) – variable differential pressure

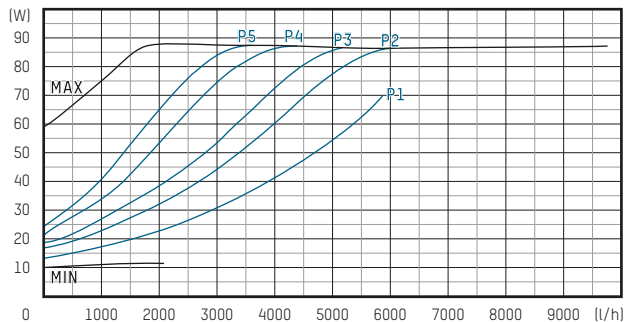

Operating mode activeADAPT - dynamic differential pressure

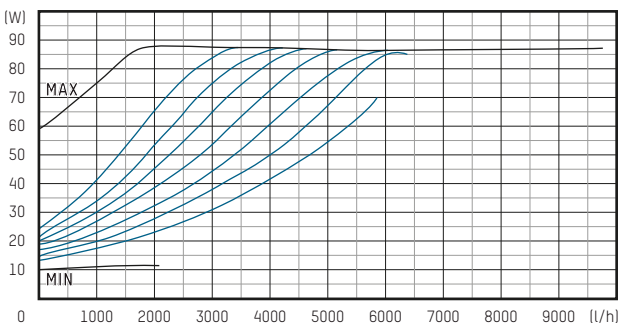

Operating mode 0 – 10 V

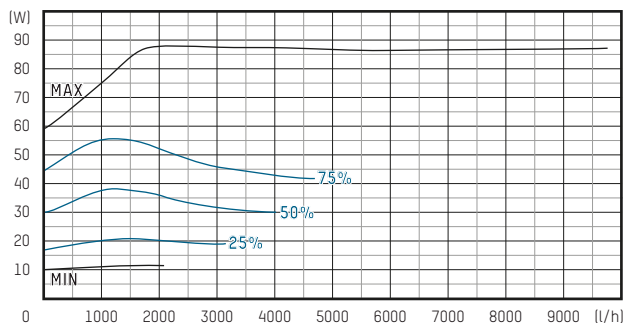

SPECIFICATION TEXT

See www.taconova.com

TECHNICAL DATA

Pump

- Ambient temperature: +0 °C to +40 °C
- Permissible temperature range: -10 °C to +110 °C
- Permissible temperature ranges at max. ambient temperature:
 - at 30 °C: +30 °C to +100 °C
 - at 40 °C: +40 °C to +70 °C
- Static pressure: Max. 1.0 MPa - 10 bar
- Minimum pressure at air intake:
 - 0.05 MPa (0.5 bar) at 80 °C
 - 0.15 MPa (1.5 bar) at 95 °C
- Max. relative humidity: ≤ 80%
- Sound pressure level: < 43 dB (A)
- Low Voltage Directive (2006/95/EC): Standards applied: EN 60335-1 and EN 60335-2-51
- EMC Directive (2004/108/EC); Standards applied: EN 61000-3-2, EN 61000-3-3
- Ecodesign Directive (2009/125/EC); Standards applied: EN 16297-1 and EN 16297-2
- Inputs/outputs: PWM, 0-10 V DC

Material

- Pump body: Cast iron, CDP-coated (EN-GJL-200)
- Impeller: Brass / Composite plastic
- Shaft: Ceramic
- Bearing: Graphite / Ceramic
- Rotor housing: Composite plastic

TECHNICAL DATA (CONTINUED)

Motor and electronics

- Supply voltage: 1x230 V (±10%), PE
frequency: 50/60 Hz
- Power rating (P1): Min. 16 W, max. 122 W
- Rated current (I1): Min. 0.2 A, max. 0.8 A
- Insulation class: F
- Protection rating: IP 44
- Temperature class: TF 110

TECHNICAL DATA (CONTINUED)

Fluids

- Heating water (VDI 2035; SWKI BT 102-01; ÖNORM H 5195-1)
- Water and proprietary additives used against corrosion and freezing up to 30 %

TYPE OVERVIEW

TacoFlow3 MAX PRO | Heating and cooling circuit pumps
Cast iron high efficiency pump with threaded and plug connection.
Standard thermal insulation shell.
Pump head: 8 m

Order no.	Designation	G	Centre distance	Weight
302.5259.000	MAX PRO 25-80/180	1 ½"	180 mm	3.5 kg
302.6259.000	MAX PRO 32-80/180	2"	180 mm	3.5 kg

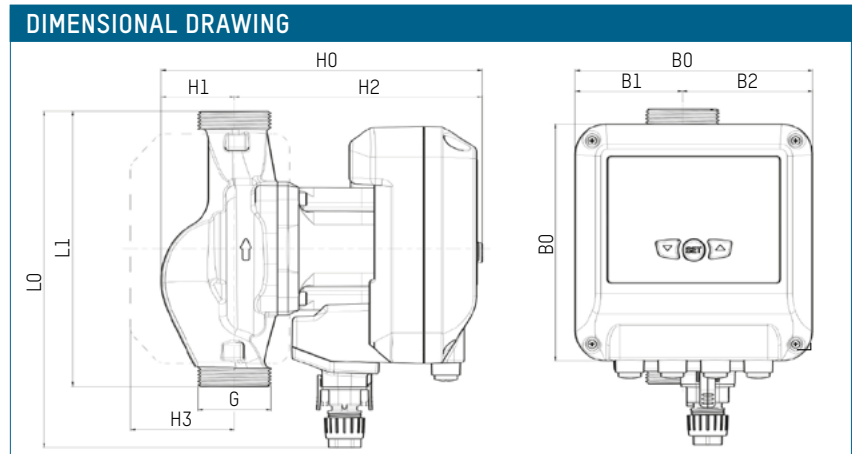

MEASUREMENT TABLE

Order no.	L0	L1	B0	B1	B2	H0	H1	H2	H3
302.5259.000	220	180	155	70	85	207	48	159	68
302.6259.000	220	180	155	70	85	207	48	159	68

ENERGY EFFICIENCY INDEX

EEI ≤ 0,22 - Part 2

Reference value for the most efficient circulation pump is EEI ≤ 0.20

PERFORMANCE CURVES

Operating mode C (Δp -c) – constant differential pressure

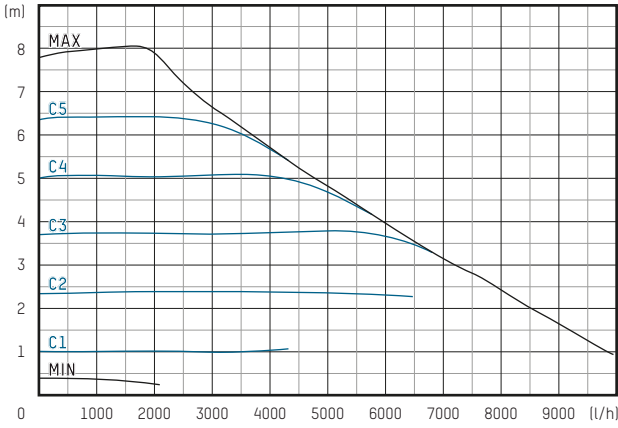

Operating mode P (Δp -v) – variable differential pressure

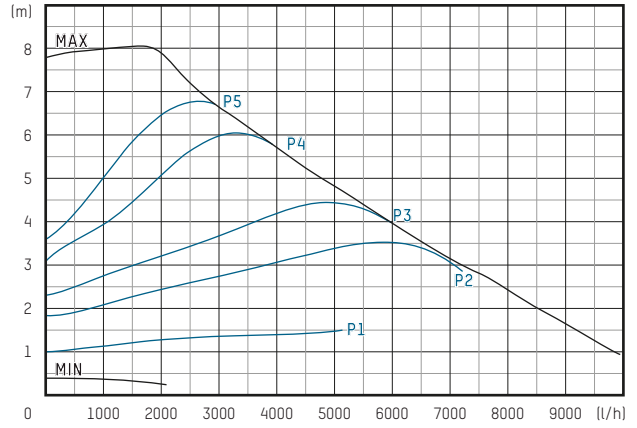

Operating mode activeADAPT - dynamic differential pressure

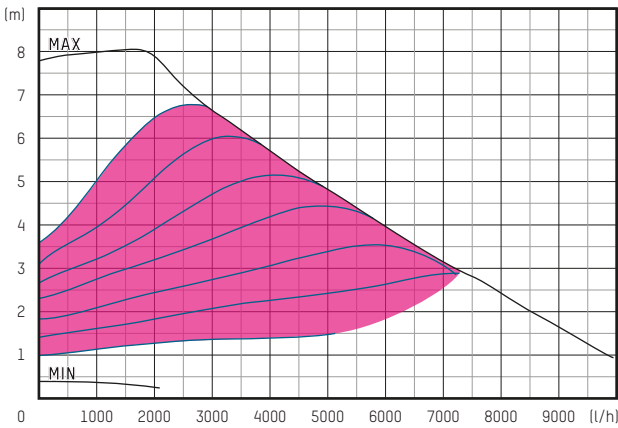

Operating mode 0 – 10 V

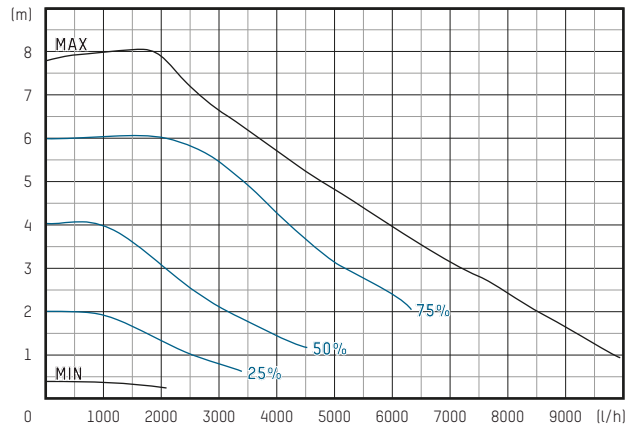

POWER CONSUMPTION CURVES

Operating mode C (Δp -c) – constant differential pressure

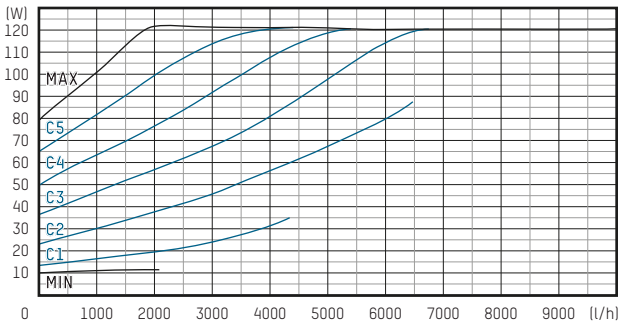

Operating mode P (Δp -v) – variable differential pressure

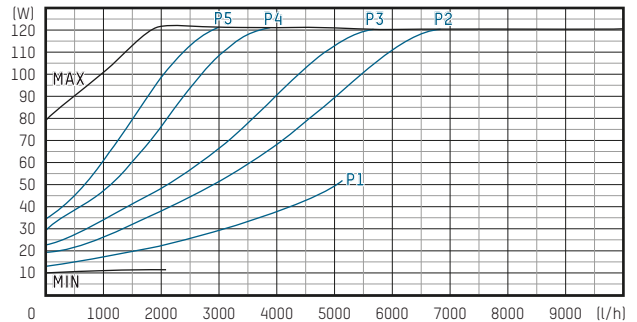

Operating mode activeADAPT - dynamic differential pressure

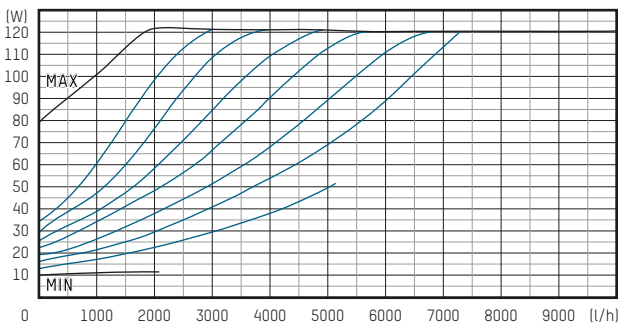

Operating mode 0 – 10 V

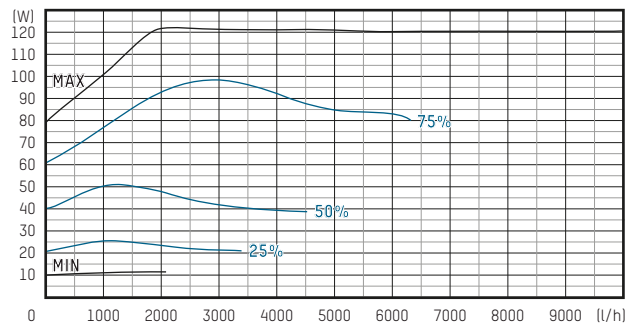

SPECIFICATION TEXT

See www.taconova.com

TECHNICAL DATA

Pump

- Ambient temperature: +0 °C to +40 °C
- Permissible temperature range: -10 °C to +110 °C
- Permissible temperature ranges at max. ambient temperature:
 - at 30 °C: +30 °C to +100 °C
 - at 40 °C: +40 °C to +70 °C
- Static pressure: Max. 1.0 MPa - 10 bar
- Minimum pressure at air intake:
 - 0.05 MPa (0.5 bar) at 80 °C
 - 0.15 MPa (1.5 bar) at 95 °C
- Max. relative humidity: ≤ 80%
- Sound pressure level: < 43 dB (A)
- Low Voltage Directive (2006/95/EC): Standards applied: EN 60335-1 and EN 60335-2-51
- EMC Directive (2004/108/EC); Standards applied: EN 61000-3-2, EN 61000-3-3
- Ecodesign Directive (2009/125/EC); Standards applied: EN 16297-1 and EN 16297-2
- Inputs/outputs: PWM, 0-10 V DC

Material

- Pump body: Cast iron, CDP-coated (EN-GJL-200)
- Impeller: Brass / Composite plastic
- Shaft: Ceramic
- Bearing: Graphite / Ceramic
- Rotor housing: Composite plastic

TECHNICAL DATA (CONTINUED)

Motor and electronics

- Supply voltage: 1x230 V (±10%), PE frequency: 50/60 Hz
- Power rating (P1): Min. 16 W, max. 175 W
- Rated current (I1): Min. 0.2 A, max. 0.9 A
- Insulation class: F
- Protection rating: IP 44
- Temperature class: TF 110

TECHNICAL DATA (CONTINUED)

Fluids

- Heating water (VDI 2035; SWKI BT 102-01; ÖNORM H 5195-1)
- Water and proprietary additives used against corrosion and freezing up to 30 %

TYPE OVERVIEW

TacoFlow3 MAX PRO | Heating and cooling circuit pumps
 Cast iron high efficiency pump with threaded and plug connection.
 Standard thermal insulation shell.
 Pump head: 10 m

Order no.	Designation	G	Centre distance	Weight
302.5269.000	MAX PRO 25-100/180	1 ½"	180 mm	3.5 kg
302.6269.000	MAX PRO 32-100/180	2"	180 mm	3.5 kg

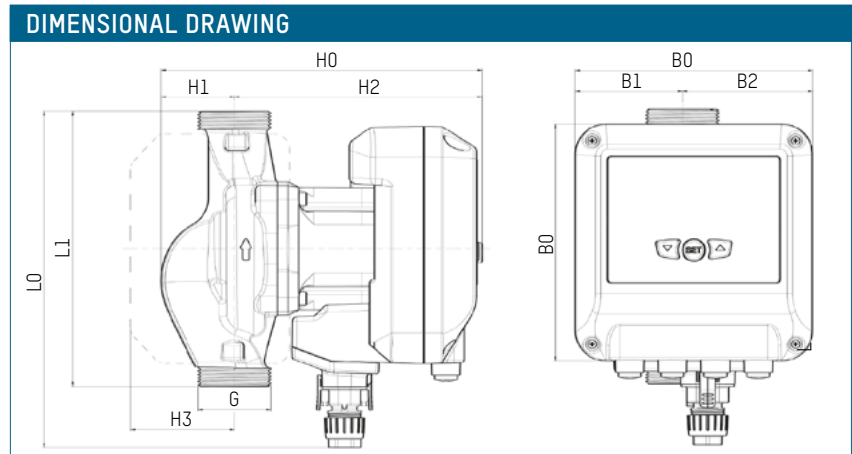

MEASUREMENT TABLE

Order no.	L0	L1	B0	B1	B2	H0	H1	H2	H3
302.5269.000	220	180	155	70	85	207	48	159	68
302.6269.000	220	180	155	70	85	207	48	159	68

ENERGY EFFICIENCY INDEX

EEI ≤ 0,22 - Part 2

Reference value for the most efficient circulation pump is EEI ≤ 0.20

PERFORMANCE CURVES

Operating mode C (Δp -c) – constant differential pressure

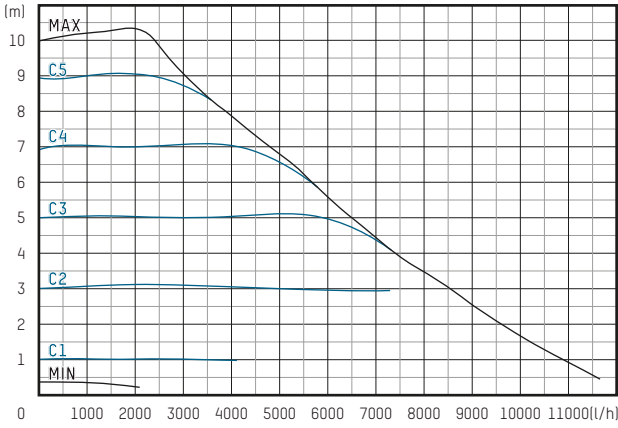

Operating mode P (Δp -v) – variable differential pressure

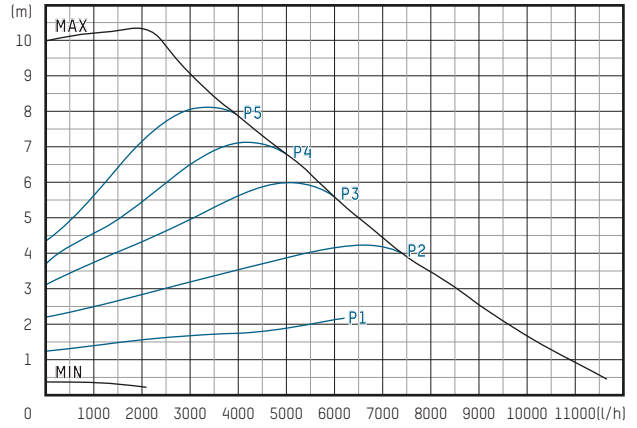

Operating mode activeADAPT - dynamic differential pressure

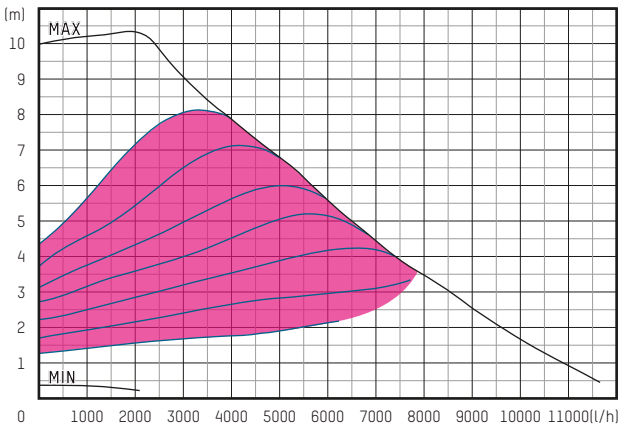

Operating mode 0 – 10 V

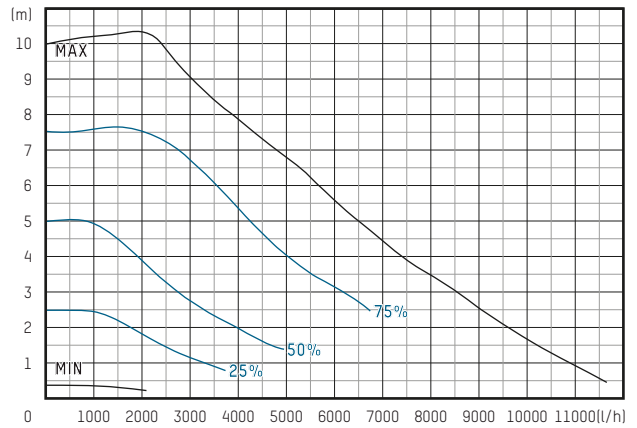

POWER CONSUMPTION CURVES

Operating mode C (Δp -c) – constant differential pressure

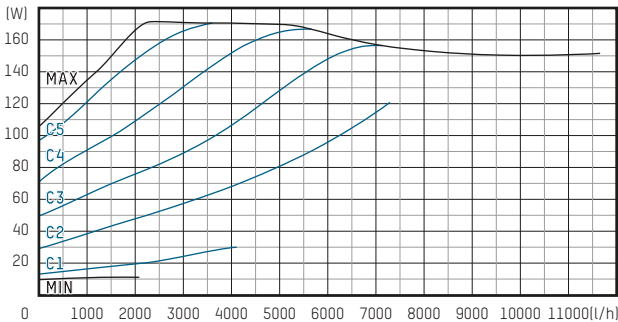

Operating mode P (Δp -v) – variable differential pressure

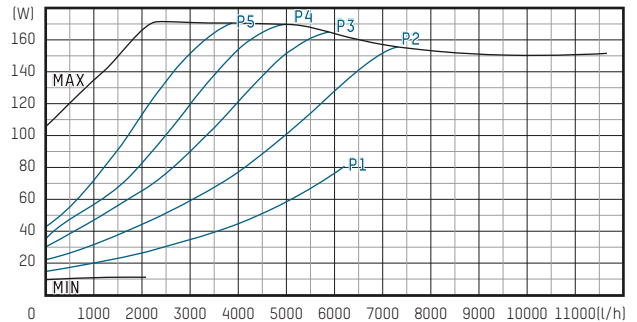

Operating mode activeADAPT - dynamic differential pressure

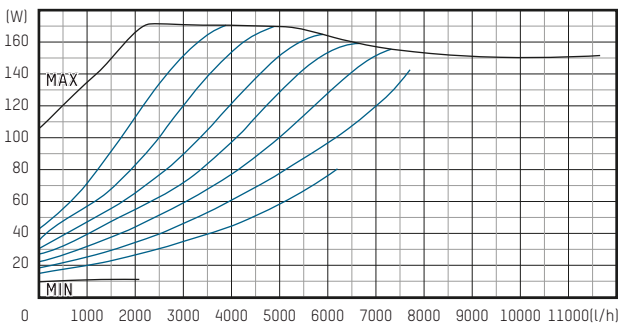

Operating mode 0 – 10 V

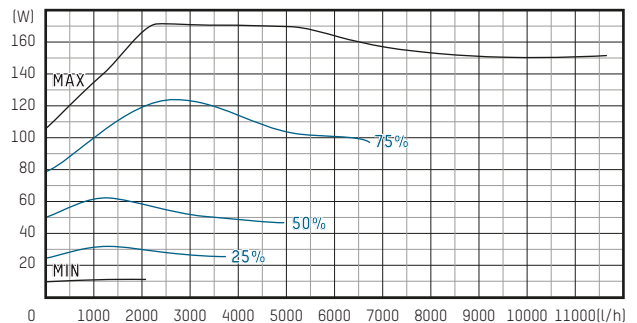

TACOFLOW2 SOLAR

CIRCULATION PUMPS FOR SOLAR THERMAL SYSTEMS



Glandless circulation pumps for solar thermal systems in residential and commercial buildings.

DESCRIPTION

The TacoFlow2 SOLAR is driven by permanent-magnet synchronous motors.

These innovative motors achieve a high efficiency at low operating costs.

They are maintenance-free and do not need replacement of seals and gaskets.

INSTALLATION POSITION

The pump can be installed both horizontally or vertically. The arrow indicating the medium's flow direction must be observed.

ADVANTAGES

- Efficient throughput setting with variable Δp -v proportional pressure curves or fixed Min-Max speed
- Media temperature range from +2 °C to +110 °C
- A colour LED indicates the current operating state

OPERATION

The circulation pump are of a glandless design, since the rotating parts of the motor run inside the pumped medium. This provides lubrication for the motor and the rotating parts. The circulation pump is equipped with anti-blocking protection, since the high efficiency pumps no longer have a pump head screw for manual unblocking. They also feature an automatic venting function, which detects and indicates any air in the pump.

BUILDING CATEGORIES

- Apartment blocks, single family dwellings, housing estates, multiple dwelling units
- Smaller public buildings
- Office, commercial and industrial buildings
- Facilities with partial use, such as barracks, camping sites

SYSTEM/BASIC DIAGRAM

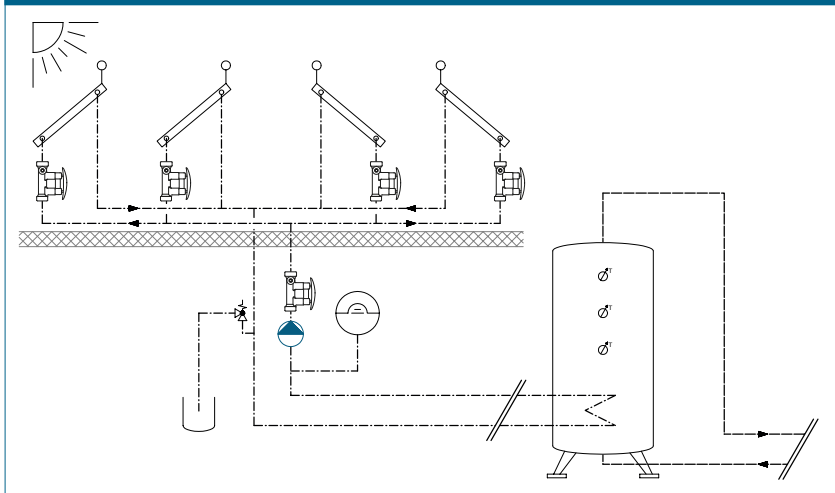

SPECIFICATION TEXT

See www.taconova.com

TECHNICAL DATA

Pump

- Ambient temperature: +0 °C to +40 °C
- Permissible temperature range*: +2 °C to +110 °C
- Permissible temperature ranges at max. ambient temperature:
 - at 30 °C: +30 °C to +110 °C
 - at 35 °C: +35 °C to +90 °C
 - at 40 °C: +40 °C to +70 °C
- Static pressure: Max. 1.0 MPa - 10 bar
- Minimum pressure at air intake:
 - 0.03 MPa (0.3 bar) at 50 °C
 - 0.10 MPa (1.0 bar) at 95 °C
 - 0.15 MPa (1.5 bar) at 110 °C
- Max. relative humidity: ≤ 95%
- Sound pressure level: <43 dB (A)
- Low Voltage Directive (2006/95/EC): Standards applied: EN 62233, EN 60335-1 and EN 60335-2-51
- EMC Directive (2004/108/EC); Standards applied: EN 61000-3-2, EN 61000-3-3, EN 55014-1 and EN 55014-2
- Ecodesign Directive (2009/125/EC); Standards applied: EN 16297-1 and EN 16297-2

Material

- Pump body: Cast iron, CDP-coated (EN-GJL-200)
- Impeller: Composite plastic
- Shaft: Ceramic
- Bearing: Graphite
- Axial thrust bearing: Ceramic
- Can: Composite plastic

* To prevent condensate in the motor and on the control electronics, the temperature of the pumped medium must always be higher than the ambient temperature.

TECHNICAL DATA (CONTINUED)

Motor and electronics

- Supply voltage: 1x230 V (±10%); frequency: 50/60 Hz
- Pump power plug
- Power rating (P1): Min. 3 W, max. 42 W
- Rated current (I1): Min. 0.03 A, max. 0.33 A
- Insulation class: H
- Protection rating: IP 44
- Safety category: II

TECHNICAL DATA (CONTINUED)

Fluids

- Heating water (VDI 2035; SWKI BT 102-01; ÖNORM H 5195-1)
- Water and proprietary additives used against corrosion and freezing up to 30 %

TYPE OVERVIEW

TacoFlow2 SOLAR | Circulation pumps for solar thermal systems
 Cast iron high efficiency pump with plug connection.
 Also suitable for heating systems.
 Pump head: 6 m

Order no.	Designation	Connection	Centre distance	Weight
302.2235.000	SOLAR 15-60/130	G 1"	130 mm	1,67 kg
302.4235.000	SOLAR 25-60/130	G 1 ½"	130 mm	1,81 kg
302.5235.000	SOLAR 25-60/180	G 1 ½"	180 mm	1,96 kg

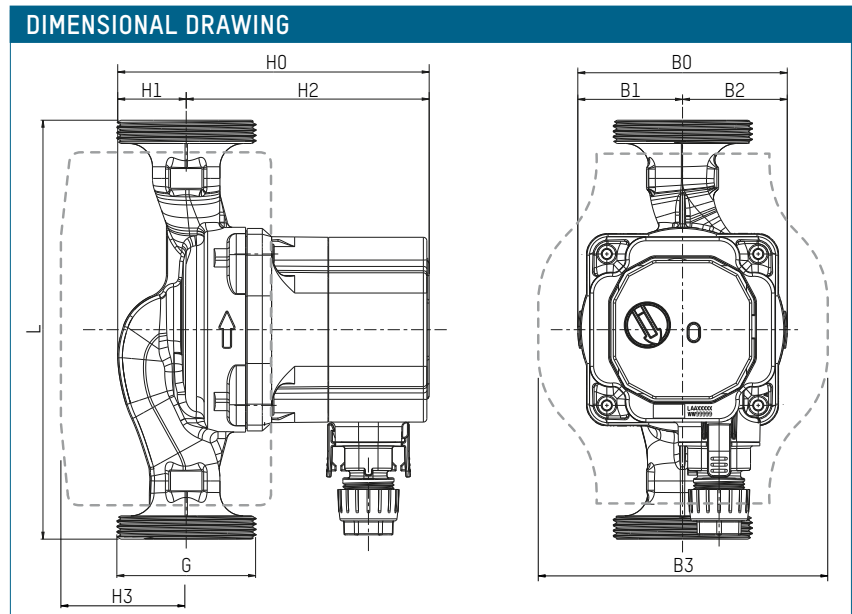

MEASUREMENT TABLE

Order no.	L	B0	B1	B2	B3	H0	H1	H2	H3
302.2235.000	130	90	45	45	124	133,8	29,4	104,4	49
302.4235.000	130	90	45	45	124	133,8	29,4	104,4	49
302.5235.000	180	90	45	45	124	133,8	29,4	104,4	49

ENERGY EFFICIENCY INDEX

EEI ≤ 0,20 - Part 2

Reference value for the most efficient circulation pump is EEI ≤ 0.20

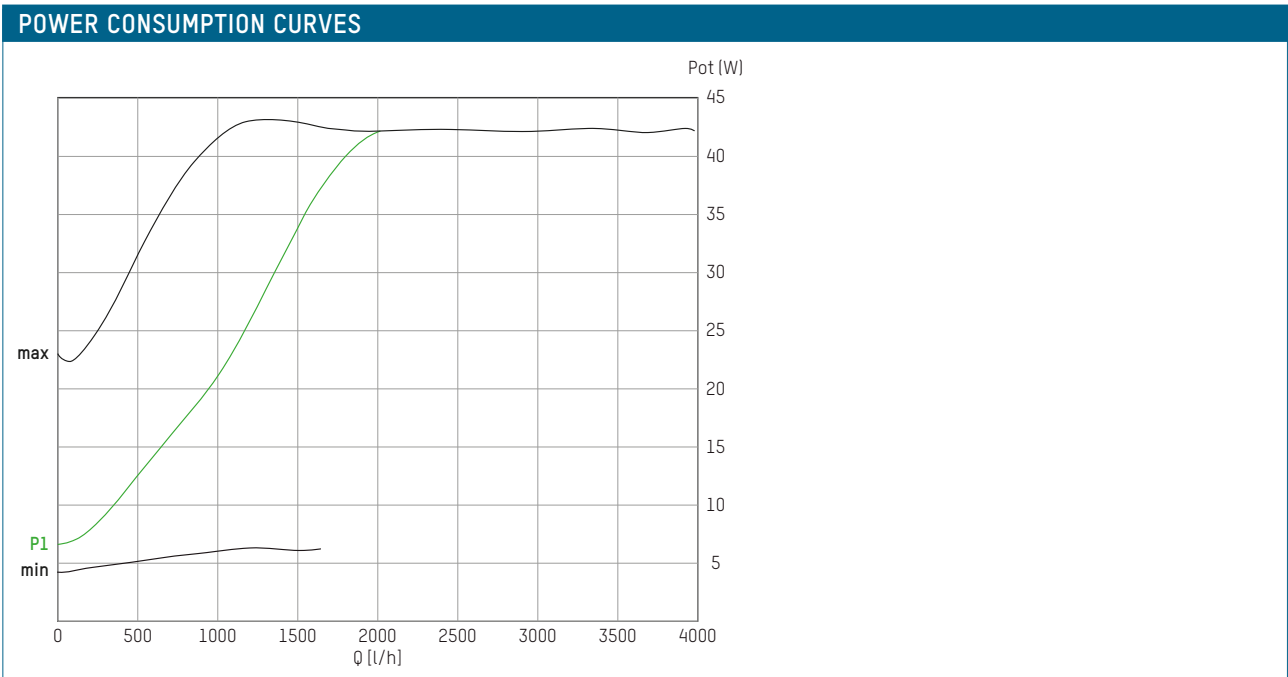
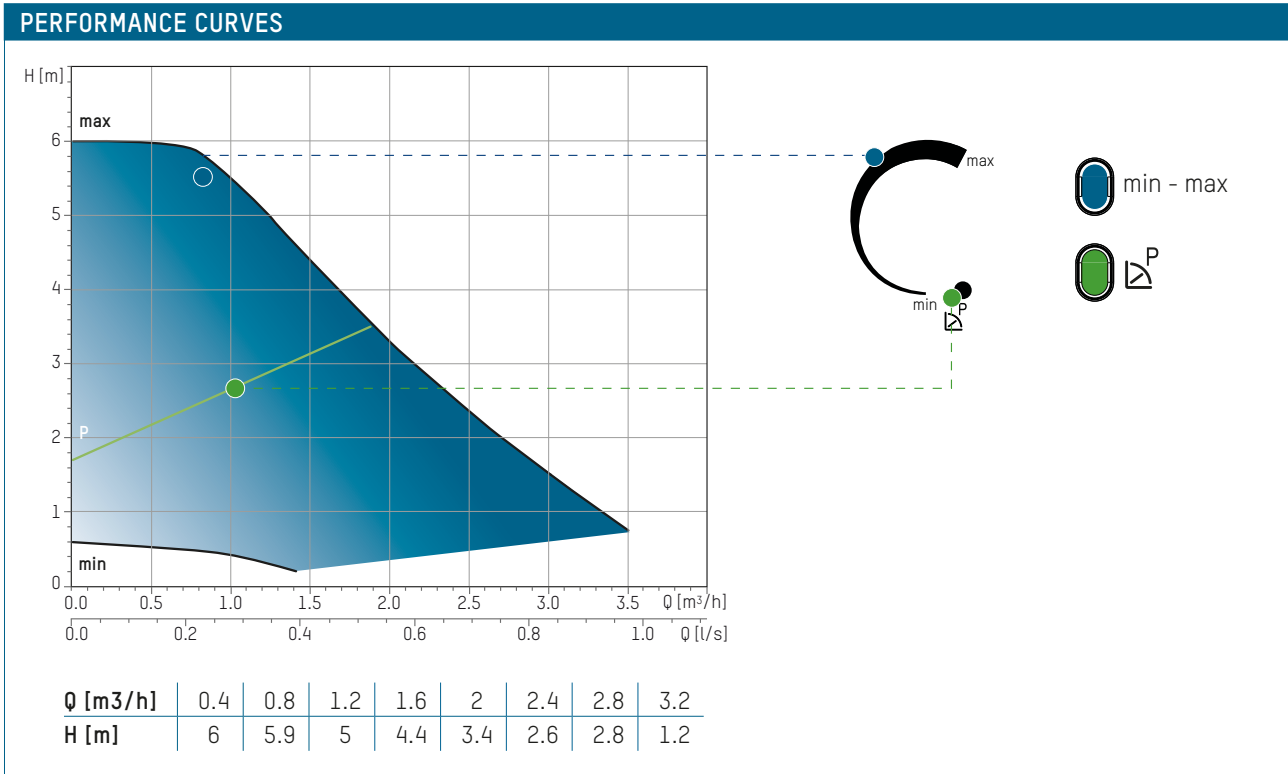

SPECIFICATION TEXT

See www.taconova.com

TECHNICAL DATA

Pump

- Ambient temperature: +0 °C to +40 °C
- Permissible temperature range*: +2 °C to +110 °C
- Permissible temperature ranges at max. ambient temperature:
 - at 30 °C: +30 °C to +110 °C
 - at 35 °C: +35 °C to +90 °C
 - at 40 °C: +40 °C to +70 °C
- Static pressure: Max. 1.0 MPa - 10 bar
- Minimum pressure at air intake:
 - 0.03 MPa (0.3 bar) at 50 °C
 - 0.10 MPa (1.0 bar) at 95 °C
 - 0.15 MPa (1.5 bar) at 110 °C
- Max. relative humidity: ≤ 95%
- Sound pressure level: <43 dB (A)
- Low Voltage Directive (2006/95/EC): Standards applied: EN 62233, EN 60335-1 and EN 60335-2-51
- EMC Directive (2004/108/EC); Standards applied: EN 61000-3-2, EN 61000-3-3, EN 55014-1 and EN 55014-2
- Ecodesign Directive (2009/125/EC); Standards applied: EN 16297-1 and EN 16297-2

Material

- Pump body: Cast iron, CDP-coated (EN-GJL-200)
- Impeller: Composite plastic
- Shaft: Ceramic
- Bearing: Graphite
- Axial thrust bearing: Ceramic
- Can: Composite plastic

* To prevent condensate in the motor and on the control electronics, the temperature of the pumped medium must always be higher than the ambient temperature.

TECHNICAL DATA (CONTINUED)

Motor and electronics

- Supply voltage: 1x230 V (±10%); frequency: 50/60 Hz
- Pump power plug
- Power rating (P1): Min. 3 W, max. 56 W
- Rated current (I1): Min. 0.03 A, max. 0.44 A
- Insulation class: H
- Protection rating: IP 44
- Safety category: II

TECHNICAL DATA (CONTINUED)

Fluids

- Heating water (VDI 2035; SWKI BT 102-01; ÖNORM H 5195-1)
- Water and proprietary additives used against corrosion and freezing up to 30 %

TYPE OVERVIEW

TacoFlow2 SOLAR | Circulation pumps for solar thermal systems
 Cast iron high efficiency pump with plug connection.
 Also suitable for heating systems.
 Pump head: 7 m

Order no.	Designation	Connection	Centre distance	Weight
302.2245.000	SOLAR 15-70/130	G 1"	130 mm	1,91 kg
302.4245.000	SOLAR 25-70/130	G 1 ½"	130 mm	2,05 kg
302.5245.000	SOLAR 25-70/180	G 1 ½"	180 mm	2,20 kg

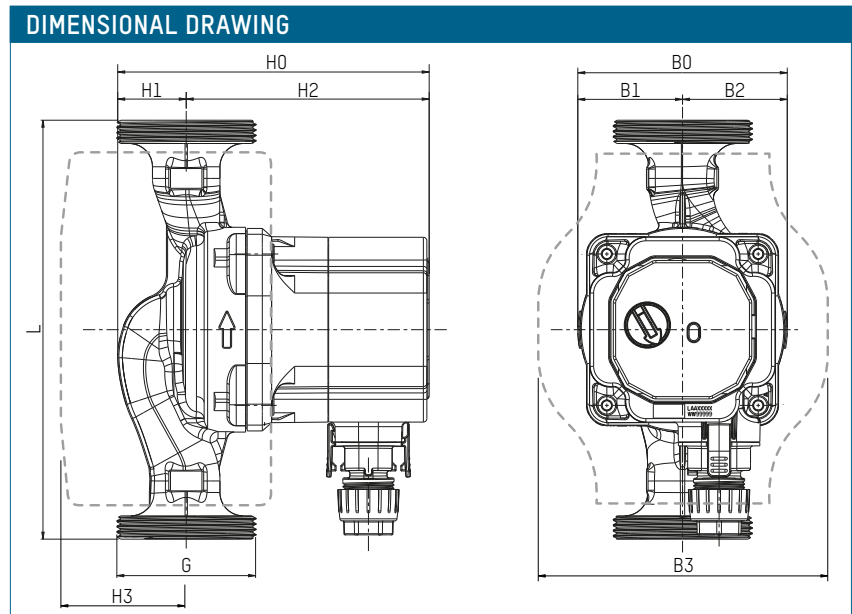

MEASUREMENT TABLE

Order no.	L	B0	B1	B2	B3	H0	H1	H2	H3
302.2245.000	130	90	45	45	124	143,8	29,4	114,4	49
302.4245.000	130	90	45	45	124	143,8	29,4	114,4	49
302.5245.000	180	90	45	45	124	143,8	29,4	114,4	49

ENERGY EFFICIENCY INDEX

EEI ≤ 0,21 - Part 2

Reference value for the most efficient circulation pump is EEI ≤ 0.20

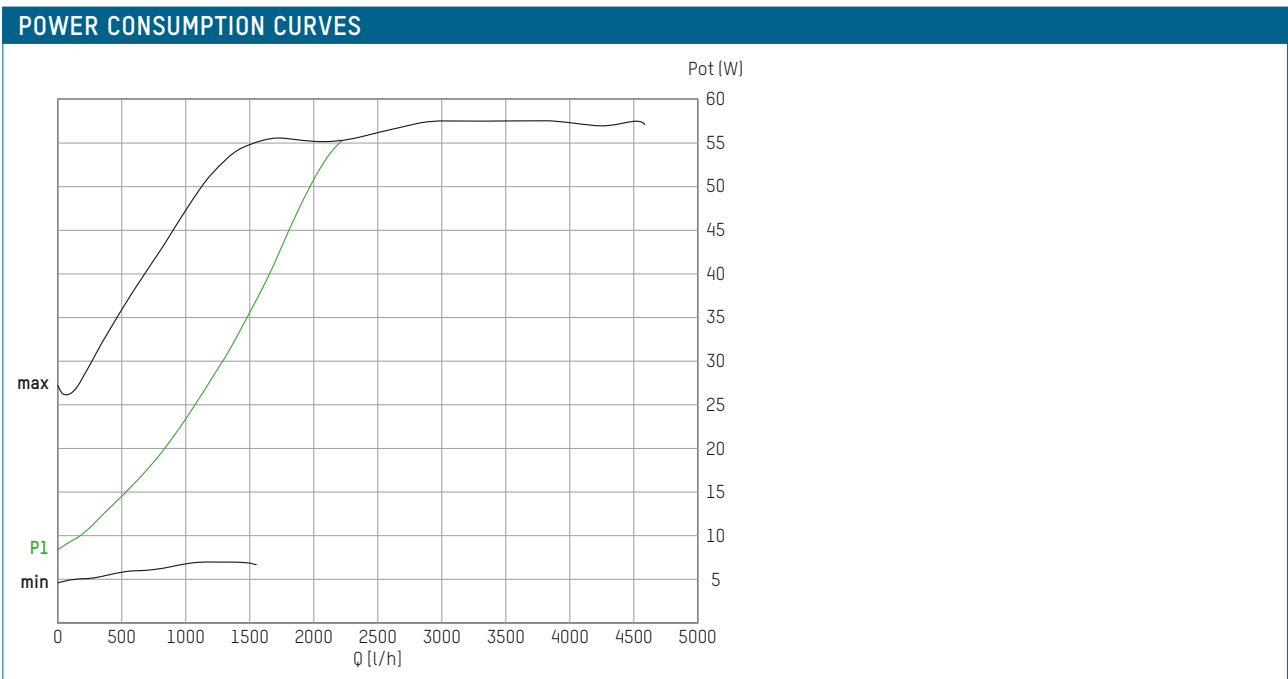
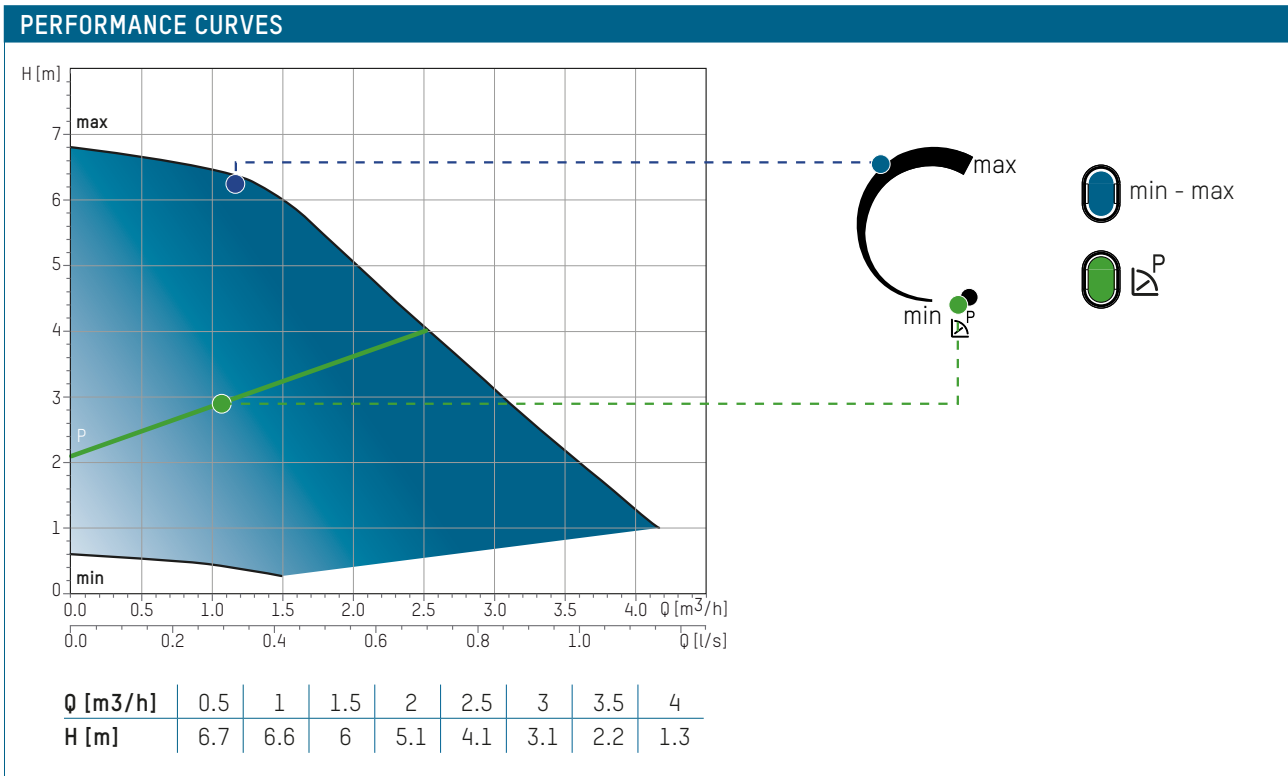

TACOFLOW2 PURE C

DHW CIRCULATION PUMPS FOR POTABLE WATER SYSTEMS



DHW circulation pumps for domestic hot water systems in residential and commercial buildings.

DESCRIPTION

The TacoFlow2 PURE C (Composite) is driven by permanent-magnet synchronous motors.

These innovative motors achieve a high efficiency at low operating costs.

They are maintenance-free and do not need replacement of seals and gaskets.

INSTALLATION POSITION

The pump can be installed both horizontally or vertically.

The arrow indicating the medium's flow direction must be observed.

ADVANTAGES

- Efficient throughput setting with fixed Min-Max speed
- Media temperature range from +2 °C to +95 °C
- A colour LED indicates the current operating state
- Suitable for use in domestic hot water systems

OPERATION

The circulation pump are of a gland-less design, since the rotating parts of the motor run inside the pumped medium. This provides lubrication for the motor and the rotating parts. The circulation pump is equipped with anti-blocking protection, since the high efficiency pumps no longer have a pump head screw for manual unblocking. They also feature an automatic venting function, which detects and indicates any air in the pump.

BUILDING CATEGORIES

- Apartment blocks, single family dwellings, housing estates, multiple dwelling units
- Smaller public buildings
- Facilities with partial use, such as barracks, camping sites

SYSTEM/BASIC DIAGRAM

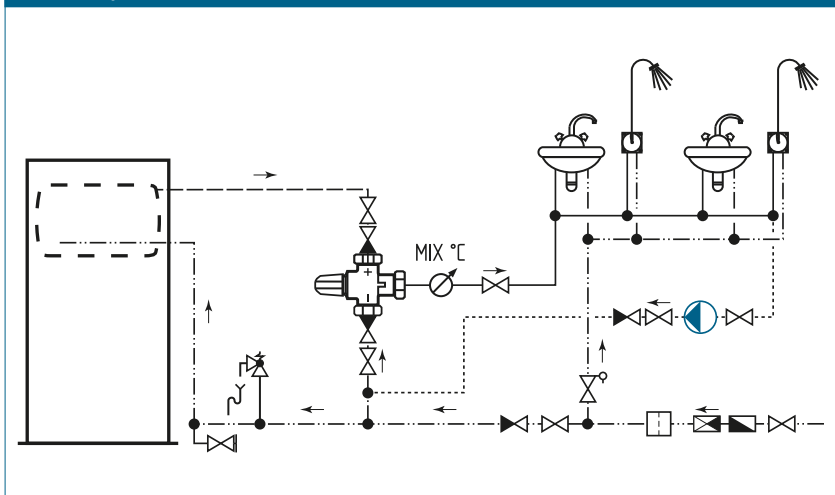

SPECIFICATION TEXT

See www.taconova.com

TECHNICAL DATA

Pump

- Ambient temperature: +0 °C to +40 °C
- Permissible temperature range*: +2 °C to +95 °C
- Permissible temperature ranges at max. ambient temperature:
 - at 30 °C: +30 °C to +95 °C
 - at 35 °C: +35 °C to +90 °C
 - at 40 °C: +40 °C to +70 °C
- Static pressure: Max. 1.0 MPa - 10 bar
- Minimum pressure at air intake:
 - 0.03 MPa (0.3 bar) at 50 °C
 - 0.10 MPa (1.0 bar) at 95 °C
- Max. relative humidity: ≤ 95%
- Sound pressure level: <43 dB (A)
- Low Voltage Directive (2006/95/EC): Standards applied: EN 62233, EN 60335-1 and EN 60335-2-51
- EMC Directive (2004/108/EC); Standards applied: EN 61000-3-2, EN 61000-3-3, EN 55014-1 and EN 55014-2
- Hydraulic unit certifications: ICIM (IT), KTW (DE), DVGW W270 (DE), ACS (FR), WRAS (GB)

Material

- Pump body: Composite plastic PA 6T/6I GF
- Impeller: Composite plastic
- Shaft: Ceramic
- Bearing: Graphite
- Axial thrust bearing: Ceramic
- Can: Composite plastic

* To prevent condensate in the motor and on the control electronics, the temperature of the pumped medium must always be higher than the ambient temperature.

TECHNICAL DATA (CONTINUED)

Motor and electronics

- Supply voltage: 1x230 V (±10%); frequency: 50/60 Hz
- Pump power plug
- Power rating (P1): Min. 4.3 W, max. 40 W
- Rated current (I1): Min. 0.03 A, max. 0.32 A
- Insulation class: H
- Protection rating: IP 44
- Safety category: II

TECHNICAL DATA (CONTINUED)

Fluids

- Drinking water < 20° dH

TYPE OVERVIEW

TacoFlow2 PURE C | DHW circulation pumps for potable water systems
 High efficiency electronic DHW circulation pump made of composite plastic, glandless design with permanent magnet synchronous motor, inverter control and plug connection.
 Pump head: 4 m

Order no.	Designation	G	Centre distance	Weight
302.1126.000	PURE C 10-40/130	3/4"	130 mm	1,47 kg
302.2126.000	PURE C 15-40/130	1"	130 mm	1,47 kg

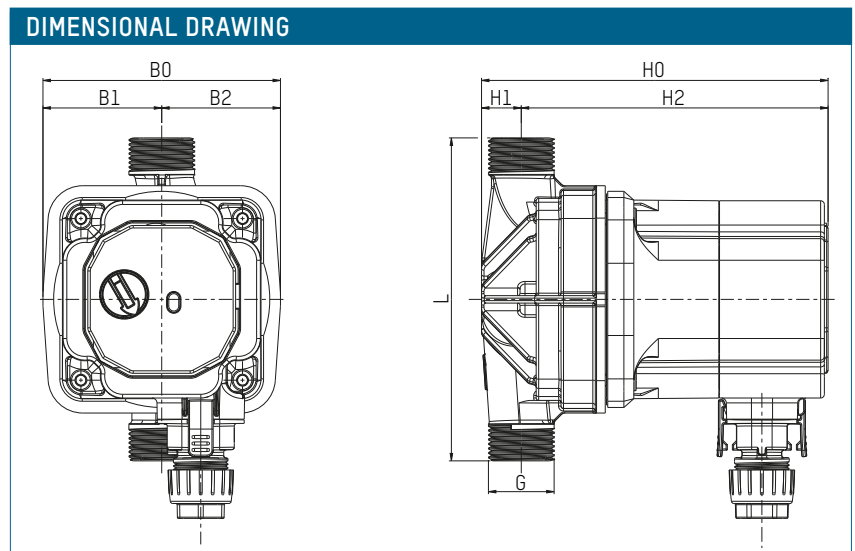

MEASUREMENT TABLE

Order no.	L	B0	B1	B2	H0	H1	H2
302.1126.000	130	95,6	47,8	47,8	139	16	123
302.2126.000	130	95,6	47,8	47,8	139	16	123

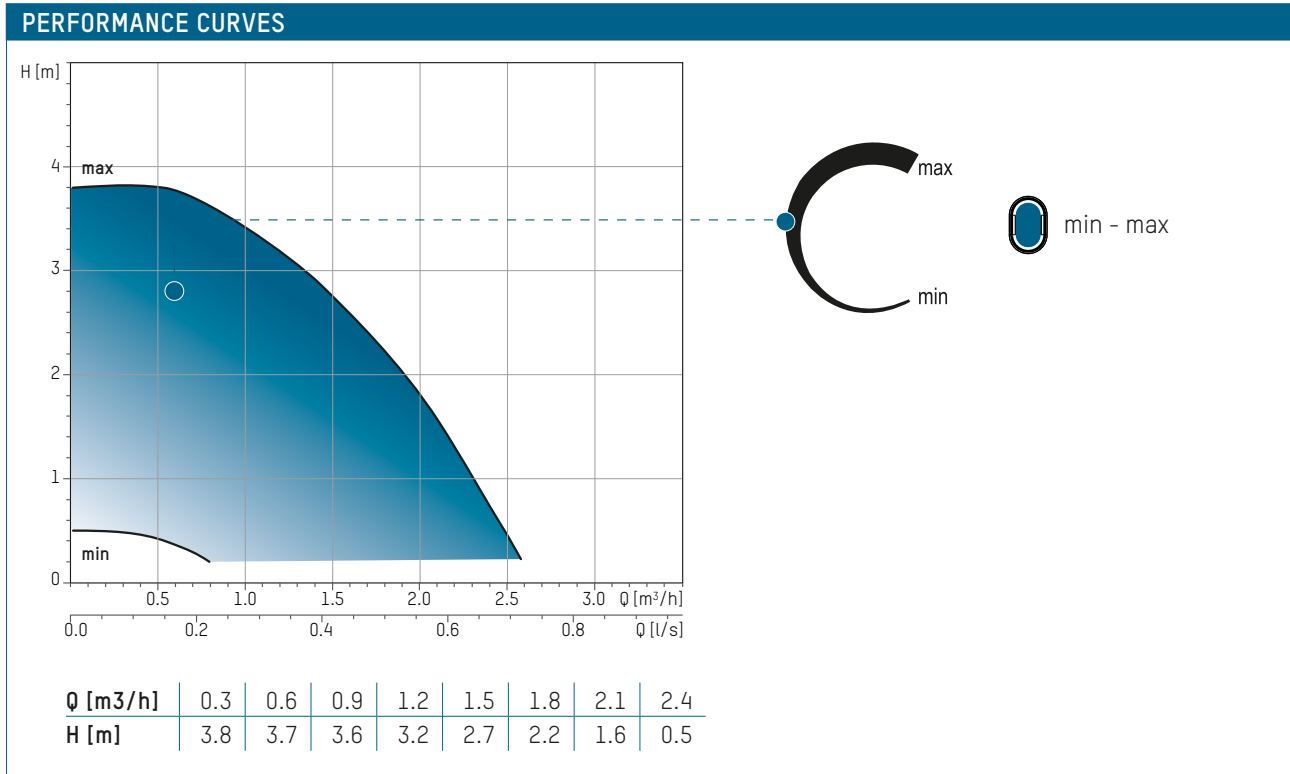

TACOFLOW2 PURE (PLUS)

DHW CIRCULATION PUMPS FOR POTABLE WATER SYSTEMS



DHW circulation pumps for domestic hot water systems in residential and commercial buildings.

DESCRIPTION

The TacoFlow2 PURE (PLUS) circulation pumps are virtually maintenance-free. You can reduce power consumption by up to 80% compared to a standard circulation pump, whilst maintaining the same hydraulic output.

INSTALLATION POSITION

The pump can be installed both horizontally or vertically. The arrow indicating the medium's flow direction must be observed.

ADVANTAGES

- Highly efficient circulation pump
- Efficient output setting with three constant-pressure curves
- Ceramic shaft
- Contact sensor for temperature control (PLUS version)
- Integrated timer for individual seven-day programming (PLUS version)
- LCD (PLUS version)
- Media temperature range from +5 °C to +65 °C
- Suitable for use in domestic hot water systems

OPERATION

The rotating parts of the motor run inside the pumped medium. This ensures the lubrication of the motor and the rotating parts. The circulation pump is equipped with anti-blocking protection. The pump can be optimally adapted to the system by selecting the most appropriate of the three available curves.

BUILDING CATEGORIES

- Apartment blocks, single family dwellings, housing estates, multiple dwelling units
- Smaller public buildings
- Facilities with partial use, such as barracks, camping sites

SYSTEM/BASIC DIAGRAM

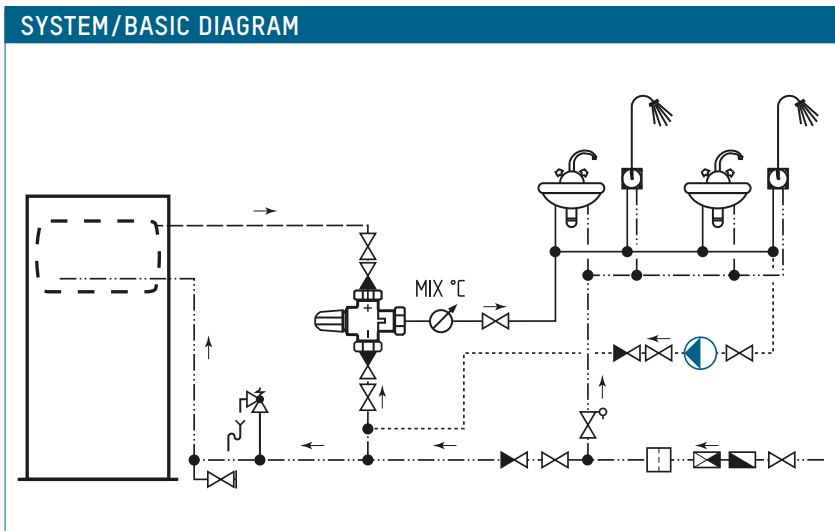

SPECIFICATION TEXT

See www.taconova.com

TECHNICAL DATA

Pump

- Ambient temperature: +0 °C to +40 °C
- Permissible temperature range: +5 °C to +65 °C
- Static pressure: Max. 1.0 MPa - 10 bar
- Maximum flow rate: 650 l/h
- Control: 3 constant characteristic curves
- Anti-blocking protection

Material

- Pump body: brass

Motor and electronics

- Supply voltage: 1x230 V; frequency: 50 Hz
- No external motor protection required
- Protection rating: IP 44

Fluids

- Drinking water < 20° dH

TYPE OVERVIEW

TacoFlow2 PURE | DHW circulation pumps for potable water systems
 High-efficiency DHW circulation pump in glandless design with brass housing, insulation shell and plug connection.
 Pump head: 1.4 m.

Order no.	Designation	Rp	Centre distance	Weight
302.2416.000	PURE 15-14/80	½"	80 mm	1,210 kg

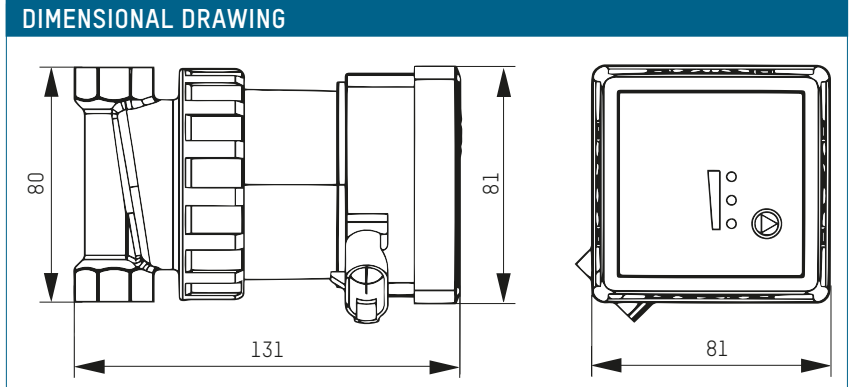

TacoFlow2 PURE PLUS | DHW circulation pumps for potable water systems
 High-efficiency DHW circulation pump in glandless design with brass housing, insulation shell and plug connection.

LCD display, integrated timer for setting individual weekly programmes and contact sensor for monitoring the temperature.

Pump head: 1.4 m.

Order no.	Designation	Rp	Centre distance	Weight
302.2417.000	PURE PLUS 15-14/80	½"	80 mm	1,170 kg

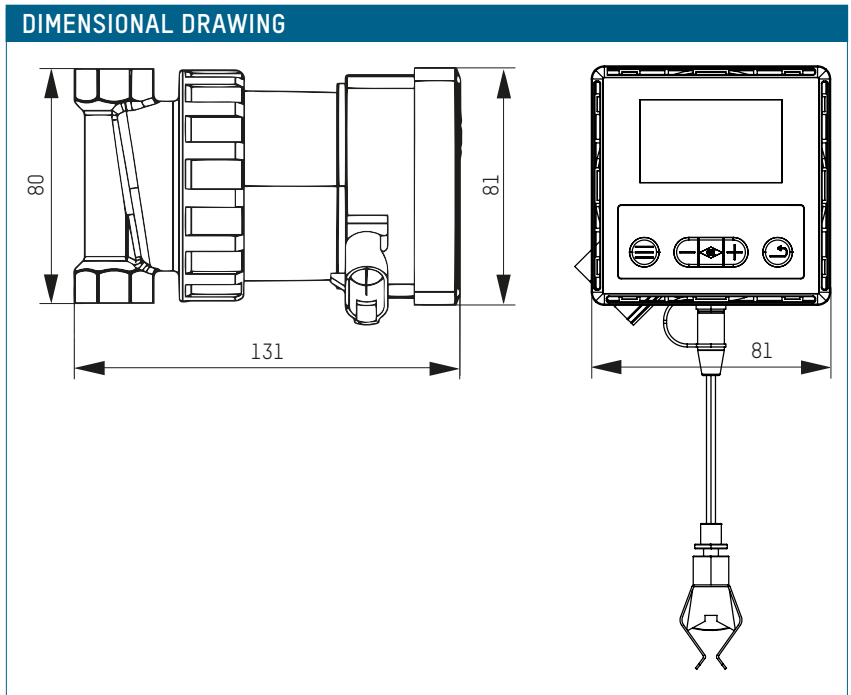

PERFORMANCE CURVES

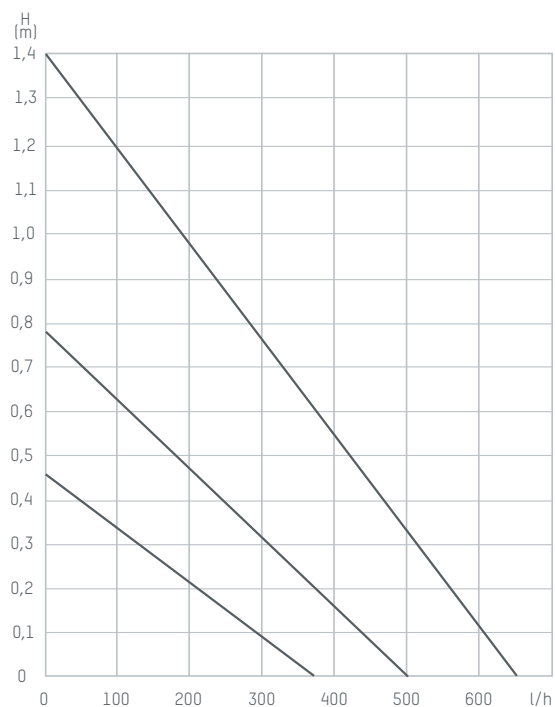

ACCESSORIES



BALL-VALVE & GRAVITY-BRAKE PLUGS

2-piece set consisting of a ball valve plug and a gravity brake plug. The set is suitable for both the PURE 15-14/80 and PURE PLUS 15-14/80. The plugs extend the pump (before: 80 mm / after: approx. 136 mm).

Order no.	Connections	Length	Total weight
231.5000.000	G ½" / G 1"	38 mm each	0,19 kg

DIMENSIONAL DRAWING

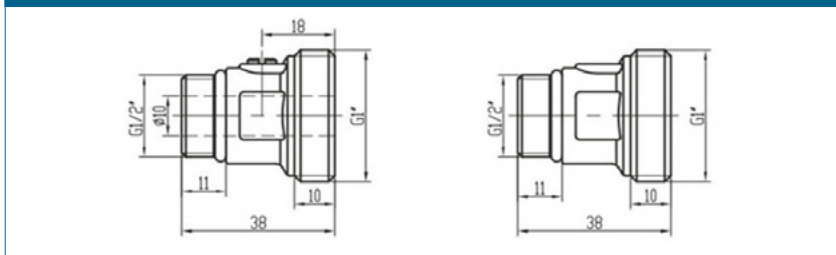

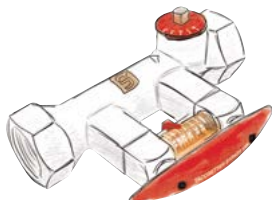

HYDRONIC BALANCING

Static or dynamic

Heat distribution for any system, matched to demand.



VALVES AND ACCESSORIES

Compact aids

For safety, greater effectiveness and convenience.

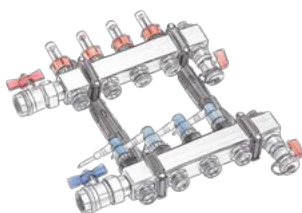

AREA HEATING SYSTEMS

Perfect interaction

For a pleasant, individual room climate.



PUMP TECHNOLOGY

Upwardly efficient

For low operating costs and greater energy efficiency.

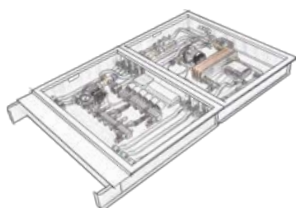

SYSTEM TECHNOLOGY

Intelligent units

For reliable operation, reduced maintenance and optimised energy costs.



Follow us on 

TACONOVA.COM

Further information

Find the latest news, product information, animations, datasheets and much more on taconova.com