

Programmable ZigBee/868MHz Smart Thermostat, 230V



E40-230W



E40-230B

FULL MANUAL

Table of contents

1. Introduction	5
1.1 Product Compliance	5
1.2 Safety Informations	5
1.3 Symbols used.....	5
2. Product Overview	6
2.1 Package content	7
2.2 Proper thermostat location	7
3. Description of thermostat terminals	8
4. Connection description	8
4.1 Connection diagram to the control box.....	8
4.2 Connection diagram to pump.....	9
4.3 Connection diagram to actuator.....	9
4.4 Connection diagram for heating source.....	9
5. Wall mounting of the thermostat, additional frame	10
6. First power on	11
6.1 LCD icon description	12
6.2 Buttons description.....	12
7. Thermostat installation without application - OFFLINE	13
7.1 Setting the day of the week and time (Offline mode).....	13
7.2 Manual mode - temperature setting.....	14
7.3 Schedule.....	15
7.4 Temporary override mode	16
7.5 System type selection (heating or cooling).....	16
7.6 Key lock function	17
8. ZigBee thermostat installation without application - OFFLINE	18
8.1 Adding the thermostat to the ZigBee network	18
8.2 ENGO Binding - wireless link between the thermostat and the receiver	19
8.2.1 Linking the thermostat to the ECB62-ZB wireless control box	19
8.2.2 Linking the thermostat with the EMOD-ZB control module	20
8.2.3 Linking the thermostat to the EREL-16ZB, EREL-12ZB relay.....	21
9. Controlling the radiator heating without the internet and apps	22
9.1 Operating principle of the radiator heating control.....	22
9.2 Installing the TRV head on a thermostatic insert.....	22
9.3 Synchronising the thermostat with the ETRV without an Internet gateway	23
10. Installer parameters in OFFLINE mode	24
11. Factory reset	25
12. Communication map	26
12.1 Wired control of underfloor heating.....	26
12.2 Wireless control of underfloor heating.....	27
12.3 Wireless control of the radiator heating.....	28
13. About ZigBee Network	29
13.1 ZigBee network creation and operation.....	29
14. About ENGO Smart	33
14.1 Mobile device requirements	33
14.2 About ENGO Smart App (general information)	33
14.3 Compatibility of devices in the ENGO SMART application.....	34
15. ENGO Smart App instalation	36

15.1 Account registration	37
15.2 Passwort reset	38
15.3 Guidelines for installing devices in a Wi-Fi network.....	39
16. Installation of the ZigBee thermostat in the app - ONLINE	40
17. ENGO Binding - wireless link between the thermostat and the receiver	42
17.1 Linking the thermostat to the ECB62-ZB wireless control box.....	42
17.2 Linking the thermostat with the EMOD-ZB control module.....	43
17.3 Linking the thermostat to the EREL-16ZB, EREL-12ZB relay	44
18. Controlling the radiator heating without the internet and apps	45
18.1 Operating principle of the radiator heating control	45
18.2 Installing the TRV head on a thermostatic insert	45
18.3 Synchronising the thermostat with the ETRV without an Internet gateway.....	46
19. Thermostat operation in the app - ONLINE	47
19.1 General information.....	47
19.2 Description of icons in the application.....	47
20. Control	48
20.1 Setpoint / temperature setting	48
20.2 On / Off	49
20.3 Manual mode	50
20.4 Schedule mode	51
20.5 Temporary schedule overwrite mode.....	54
20.6 Frost mode.....	55
20.7 Diagrams.....	56
21. Settings in the application (installer parameters)	57
21.1 Key lock function	57
21.2 Setting PIN	58
21.3 Display brightness	59
21.4 Maximum temp. limit	60
21.5 Minimum temp. limit.....	60
21.6 Temperature correction.....	61
21.7 Control algorithm	62
21.8 Relay type.....	63
21.9 VP valve protection and ANTISTOP function.....	64
21.10 Settings for TRV radiator head	65
21.10.1 Changing the head name.....	65
21.10.2 Triggering head update	66
21.10.3 Battery condition in the TRV head.....	67
21.10.4 Protection against head freezing	68
21.10.5 Control of TRV - ΔT RCWC algorithm.....	69
21.11 Heating/Cooling mode selection	71
22. General management.....	72
22.1 Change the name, icon and location of the thermostat	72
22.2 Supported external control (voice assistants)	74
22.2.1 Integration with Amazon Alexa	74
22.2.2 Integration with Google Assistant	77
22.3 Device information.....	80
22.4 „Tap-To-Run” Scenery and „Automation” of related activities.....	81
22.5 Create a group.....	92
22.6 FAQs and feedback.....	94

22.7 Add an icon to the home screen (create a shortcut on the phone's desktop)	95
22.8 Check available updates for a single device	96
22.8.1 Updating devices automatically	96
22.8.2 Updating devices manually	97
22.8.3 Checking whether updates are available for installed devices.....	98
23. Sharing facilities/home with other users.....	99
24. Alarms / Push notifications / Emergency states.....	101
25. Removing the device from the application.....	103
26. Factory reset	104
27. Cleaning and maintenance	104
28. Technical data	105
29. Warranty	106

1. Introduction

1.1 Product Compliance

The product complies with the following EU directives: 2014/53/EU and 2011/65/EU.

1.2 Safety Informations

Please read this manual in its entirety before commencing installation and operation.

- The regulator must not be used improperly.
- The information contained in these instructions is essential for proper operation.
- In order to avoid accidents resulting in personal injury and material damage, all safety rules detailed in these instructions must be observed.
- The regulator must not be used with a damaged housing.
- Under no circumstances modifications be made to the design of the regulator is not allowed.
- It is forbidden to use a faulty device or one repaired by an unauthorised service.
- The device should not be used by persons with limited mental, sensory or intellectual capacity, without experience, with insufficient knowledge, as well as children.
- Keep the appliance away from children and ensure that they do not play with it. Children should not be left unattended.
- Do not leave the packaging, casing, or any loose parts of the appliance unattended, as they are a danger to children.

INSTALLATION:

- Installation must be carried out by a qualified person with the appropriate electrical license, in accordance with the standards and regulations in force in your country and in the EU.
- Never attempt to connect the appliance in any way other than that described in the instructions.
- The device must not be exposed to extreme temperatures, strong vibrations or subjected to mechanical impacts.
- The device should not be used in adverse environmental conditions.

NOTE

- There may be additional protection requirements for the entire installation, which are the responsibility of the installer.

1.3 Symbols used



The symbol indicates the need to press a button on the thermostat or on the mobile app according to the instructions in the individual sections of this manual.



The symbol indicates important information on which damage to property, danger to human life and to pets may depend.



Concern for the environment is of paramount importance to us. Knowing that we manufacture electronic devices obliges us to dispose of used electronic components and equipment safely. For this reason, the company has received a registration number issued by the Chief Inspector of Environmental Protection. The symbol of the crossed-out rubbish bin on the product means that the product must not be disposed of in normal waste bins. Recycling helps to protect the environment. It is your responsibility to take your used equipment to a designated collection point for waste electrical and electronic equipment.

2. Product Overview

The ZigBee/868 MHz Internet temperature controller in surface-mounted design is mains-powered (230V AC). The product is based on ZigBee/868MHz wireless communication technology. It is designed for radiator or floor heating. It works with electronic wireless heads. It can control as many as 6 radiator heads in one room. Measuring the room temperature away from the radiator ensures comfort and economy. A unique feature of this controller is the ability to control devices WITHOUT WIRES (ENGO binding function). The “ENGO binding” function provides a direct link between the controller and receivers, such as a wireless control box, module or relay (“BIND” function device). ZigBee binding can only be done using an Internet gateway (sold separately). If the controller is used with an Internet gateway connected to the Internet, it has the ability to control wirelessly using the ENGO Smart mobile app. When added to the mobile app, the regulator receives further functions, such as the ability to program time schedules or push notifications. The controller has a key lock function, minimum and maximum set temperature settings, and the ability to operate in heating or cooling mode.

Product features:

- Designed for underfloor or radiator heating
- Works with ETRV electronic heads
- Can control up to 6 radiator heads in one room
- Measures the room temperature away from the radiator for comfort and economy
- Can be programmed and operated with the ENGO Smart application (using a web gateway)
- Offline operation without web gateway possible
- It can be connected to a wired underfloor heating control box
- Can control wirelessly EMOD-ZB, ELEL-12ZB or ELEL-16ZB relays
- Communicates with wireless receivers, e.g. an ECB62-ZB control box for underfloor heating
- Voice control using Alexa/Google Home

2.1 Package content

- 1) E40-230 regulator
- 2) Wall mounting plate
- 3) Quick reference guide
- 4) Mounting screws



Regulator E40-230W (white or E40-230B (black)



wall mounting plate white or black



Quick reference guide

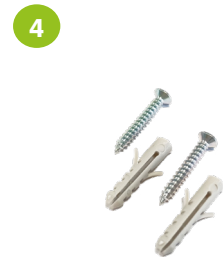

Mounting screws

2.2 Proper thermostat location

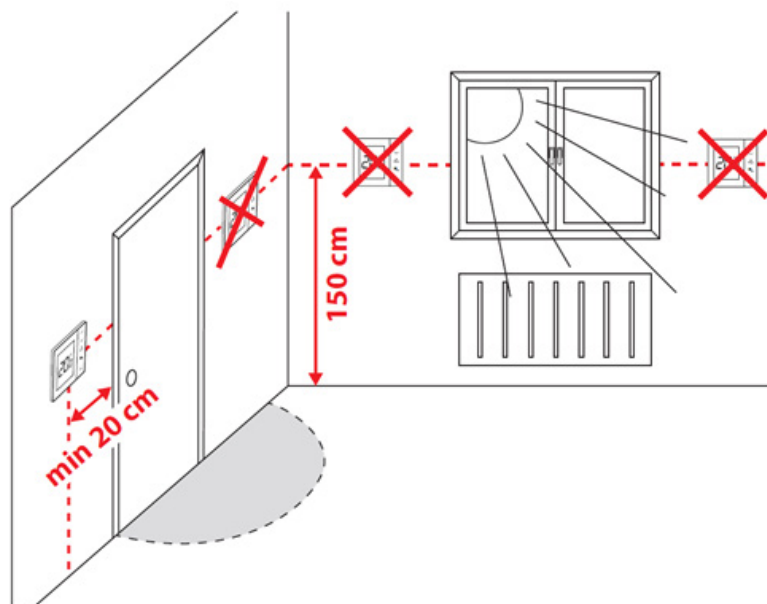



Attention:

The recommended height for mounting the thermostat is approximately 1.5 m above ground level, away from any source of heat or cold. It is not recommended to mount the thermostat on an external wall, in a draught or where it will be exposed to direct sunlight.

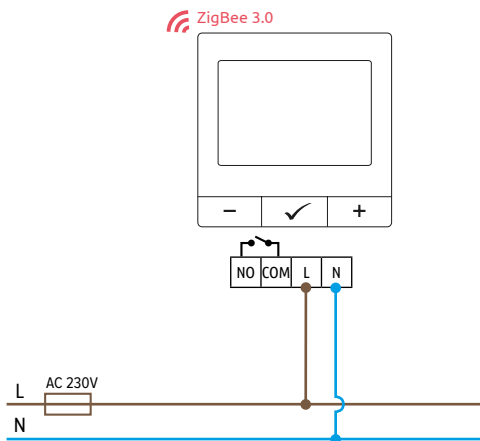
3. Description of thermostat terminals



Legend:

- L, N** 230V Power supply
- COM, NO** Voltage-free output
-  Fuse
-  Connection with ZigBee 3.0 network

4. Connection description

4.1 Connection diagram to the control box

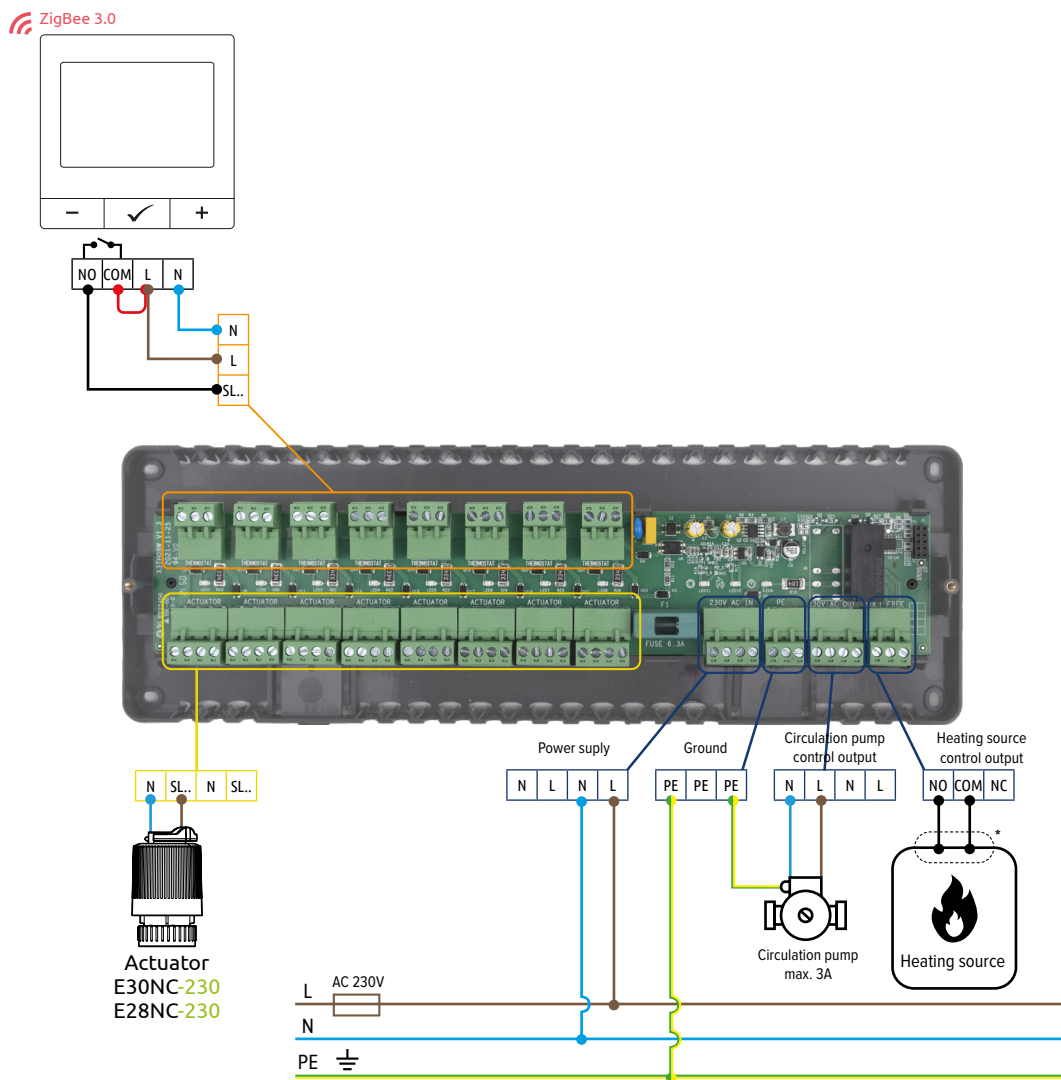

4.2 Connection diagram to pump

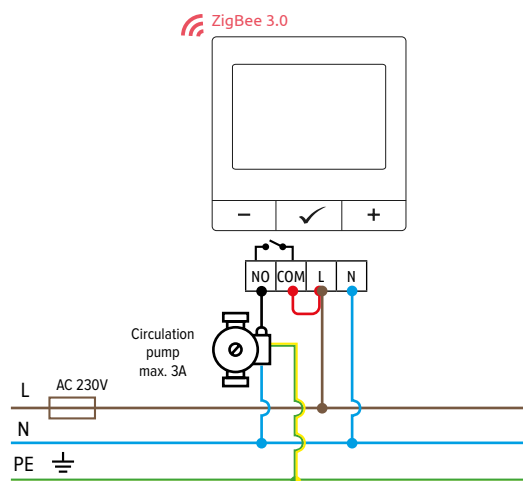



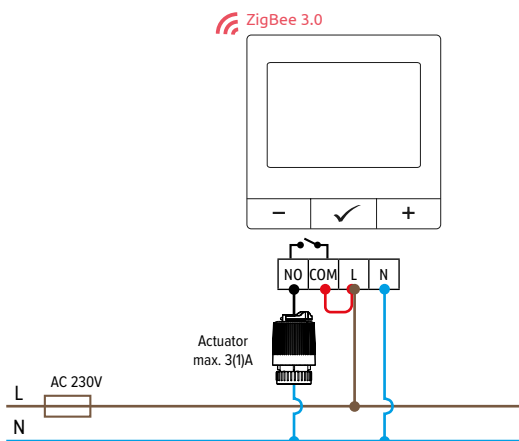

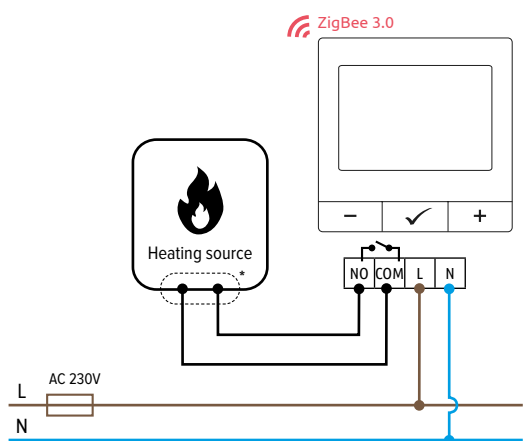

4.3 Connection diagram to actuator



4.4 Connection diagram for heating source



LEGEND:

 Fuse	 Circulation pump
L, N 230V AC power supply	 Actuator
PE  Ground	 Wireless communication
COM, NO Volt-free output	Boiler - Boiler connection * - Boiler's contacts for ON/ OFF thermostat (according to the boiler's instructions)
SL.. Designation of the input in the control box	

5. Wall mounting of the thermostat, additional frame

Use the accessories included in the kit (mounting screws) to mount the regulator correctly. Remove the back plate from the regulator in order to mount it on the wall. Then place the regulator on the plate using the movement as shown.



1 Prepare the frame and regulator

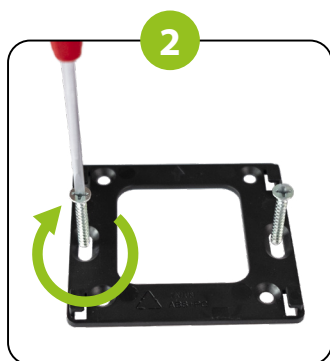

2 Screw the mounting plate to the box/wall

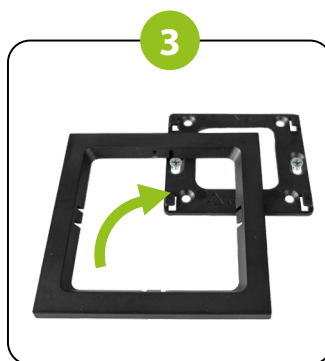

3 Attach the frame to the mounting plate

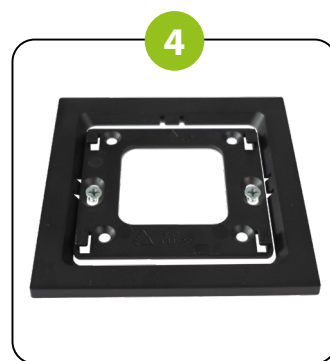

4 Make sure the frame hangs evenly

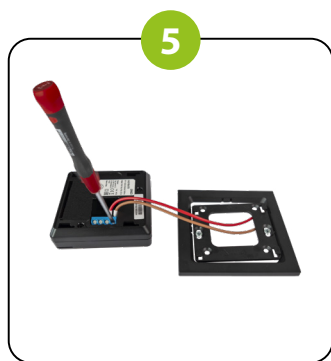

5 Connect the wires to the thermostat



6 Put the regulator on the frame



7 Attachment of regulator to mounting plate



8 The thermostat in the frame is ready for operation



Attention:

The optional EBEZEL-W (white) or EBEZEL-B (black) frame is an accessory available as an add-on.

6. First power on

The regulator is powered by 230V. When properly connected to the power supply, the regulator will start up showing all the icons, and then will go to the main screen.

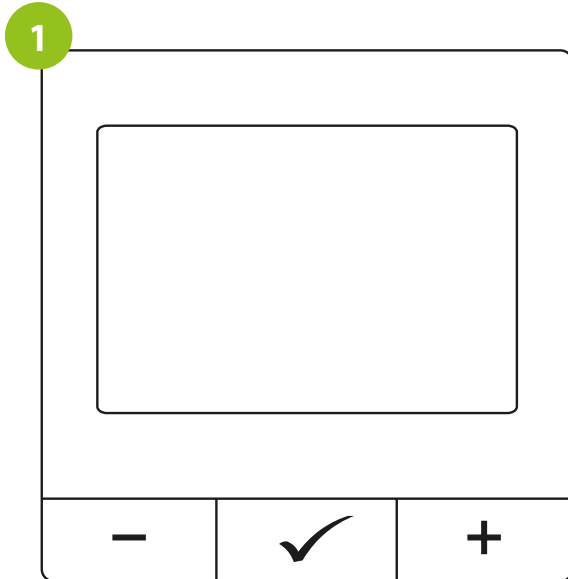

In order to turn on the regulator, it must be connected to 230V....

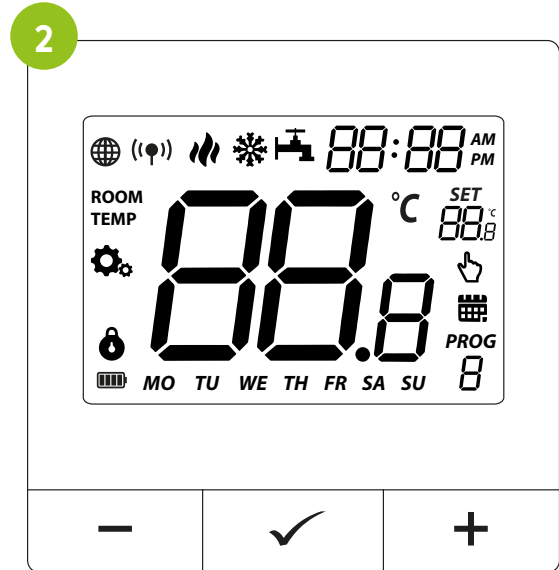

The display will show all the icons....

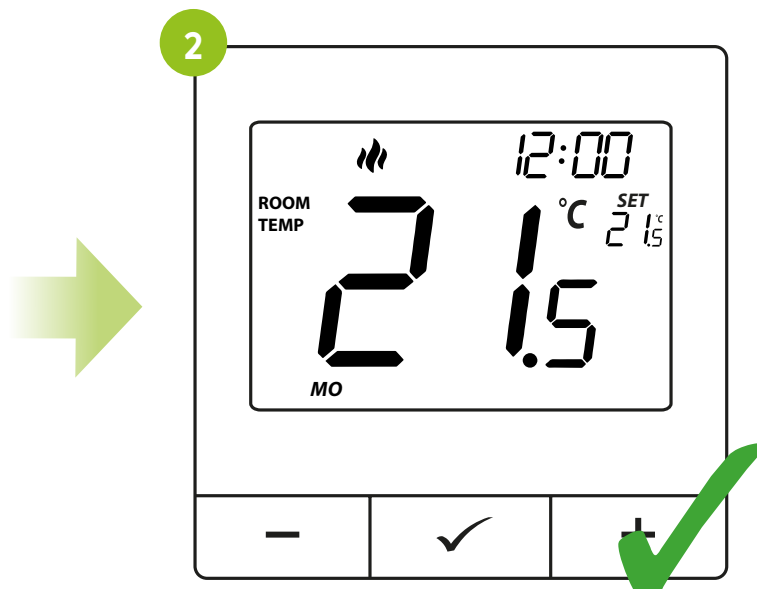

... the main screen will be displayed.

6.1 LCD icon description

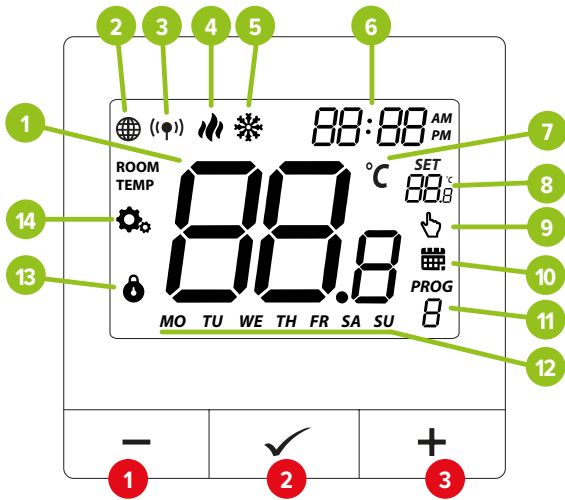

1. Current temperature
2. ZigBee network connection indicator
3. Receiver binding indicator
4. Heating indicator (icon is animating when there is heating demand)
5. Cooling indicator (icon is animating when there is cooling demand)
6. Clock
7. Temperature unit
8. Setpoint temperature
9. Temporary override mode
10. Schedule mode icon
11. Program number
12. Day of the week indicator
13. Button lock
14. Settings icon

1. "Down" Button -
2. "OK" Button OK
3. "Up" Button +

6.2 Buttons description

+	Change the parameter value up
-	Change the parameter value down
✓	Manual/Schedule mode - short button press (Online mode)
	Enter the schedule programming/installer parameters - hold for 3 seconds
	Turn OFF/ON thermostat - hold 5 seconds
+ & -	Enter the pairing mode - hold 5 seconds
	Enter Sync / Binding mode - hold 5 seconds
	Factory reset - hold until the FA message appears
+ & ✓	Lock/Unlock thermostat keys - hold 3 seconds
- & ✓	Heating/Cooling mode change - hold 3 seconds

7. Thermostat installation without application - OFFLINE

7.1 Setting the day of the week and time (Offline mode)



Attention:

To ensure proper operation of the thermostat, the time must be set first.

To set the clock format, current time, and day of the week, follow the steps below:

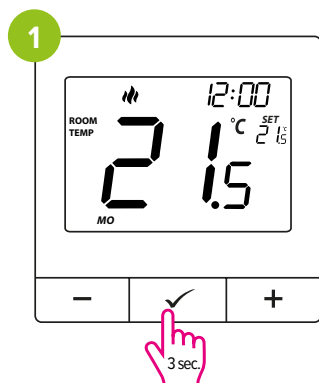

To enter clock settings press and hold ✓ button for 3 seconds.

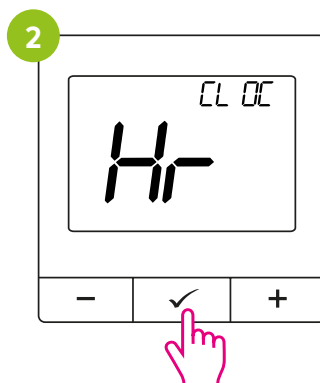

Select "Hr" with the - or + button and confirm with the ✓ button.

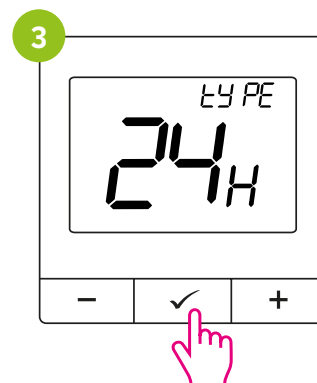

Using the - or + buttons, set the clock format, then confirm with ✓ button.

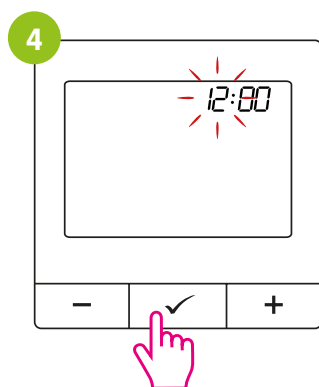

Using the - or + buttons, set the hour, then confirm with ✓ button.

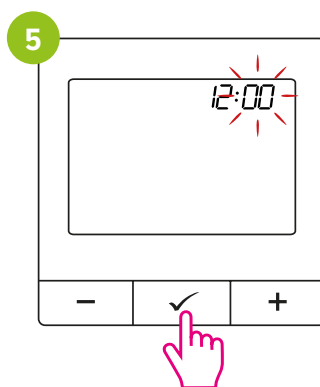

Using the - or + buttons, set the minutes, then confirm with ✓ button.

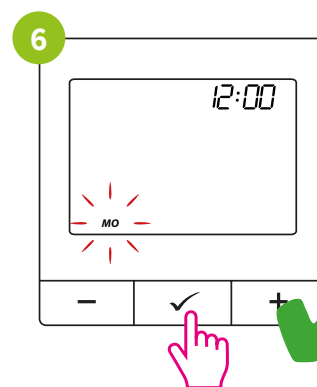

Using the - or + buttons, set the day of the week, then confirm with ✓ button.



Attention:

If the thermostat is added to the app, the time is automatically updated and synchronized from the Internet.

7.2 Manual mode - temperature setting

In manual mode, the controller maintains a constant setpoint temperature until the user changes its value or switches to Auto mode (schedule). To set manual mode, follow the steps below:

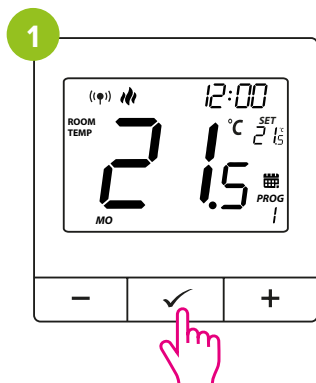

To switch the operating mode from schedule to manual mode, press the ✓ button.

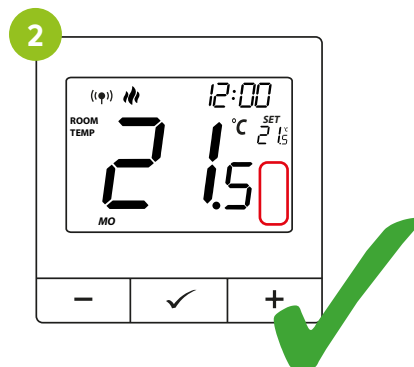

The schedule information has disappeared from the display. The controller has switched to manual mode.

To change the setpoint temperature in manual mode, follow the steps below:

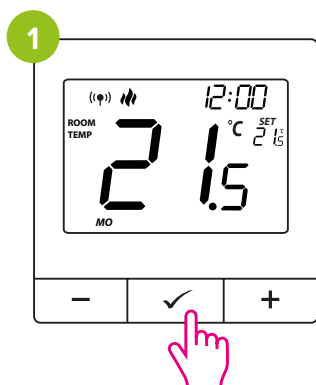

Using the - or + buttons, set the temperature, then confirm with ✓ button or wait 3 seconds.

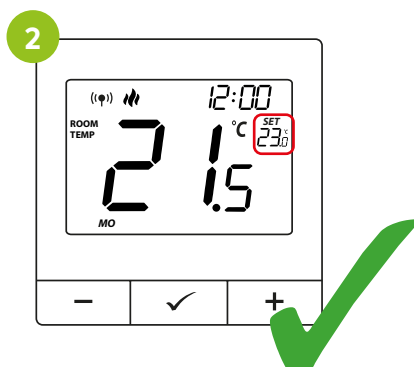

The setpoint temperature has been changed and is displayed on the right side of the screen as "SET".

7.3 Schedule

To set the schedule, follow the steps below:

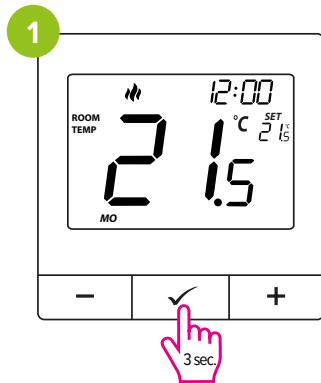

To enter schedule settings press and hold ✓ button for 3 seconds.

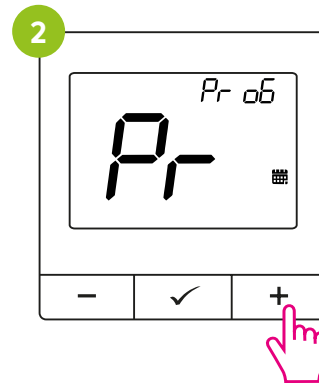

Select "Pr" with the - or + button and confirm with the ✓ button.

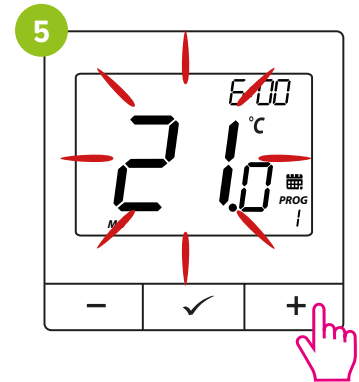
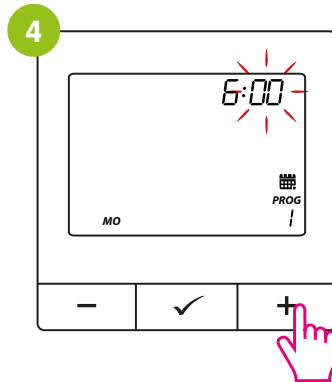
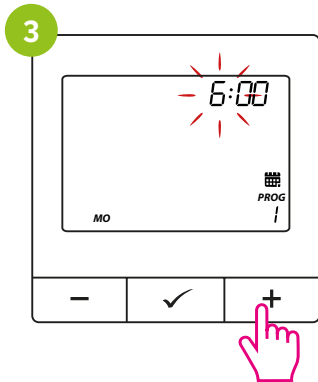

Using the - or + buttons, set the hour, minutes, and temperature for the first time slot, confirming each selection with the ✓ button.

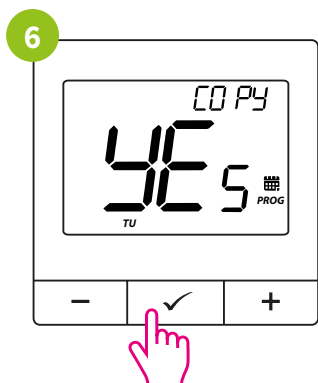

The set schedule can be copied to the next day by changing the Copy parameter to YES using the - or + buttons, and then confirming with the ✓ button.

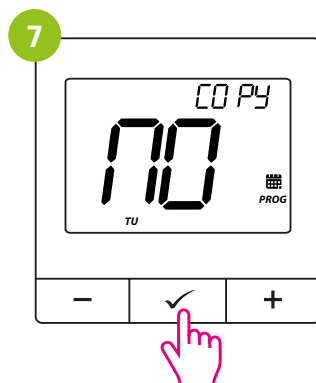

If you want to set an individual schedule for the next day of the week, set the Copy parameter to NO and confirm the selection with the ✓ button.

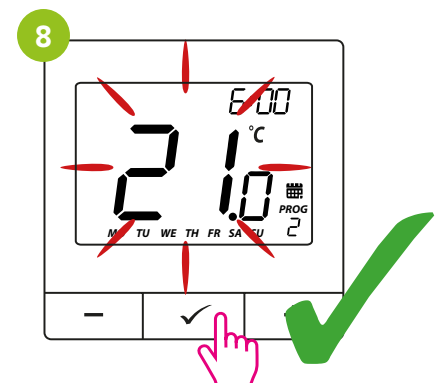

Create the schedule for the next day of the week (see steps 3–5).

Attention:

Programs must be set for all days of the week!

7.4 Temporary override mode

When thermostat is running schedule mode (AUTO) we can temporarily override it by setting new setpoint temperature:

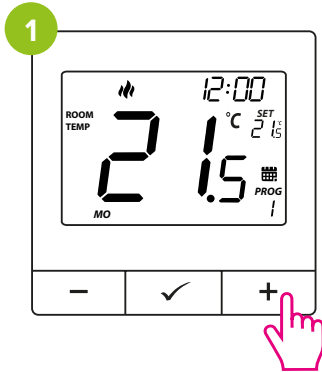

Using the - or + buttons, set the temperature, then confirm with ✓ button or wait 3 seconds.

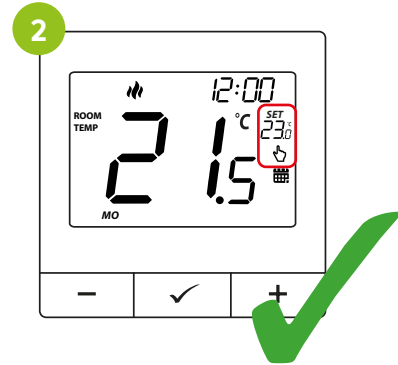

The setpoint temperature has been temporarily changed and is displayed on the right side of the screen ("SET"). An icon has appeared on the screen.

Attention:

The overridden temperature will be maintained until the next schedule change occurs. At that point, the icon will disappear from the display, and the controller will return to AUTO mode.

7.5 System type selection (heating or cooling)

To change the system type, follow the steps below:

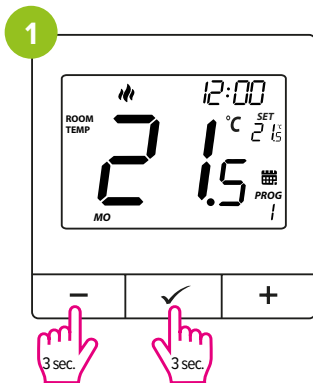

Press and hold - and ✓ buttons again for 3 seconds.

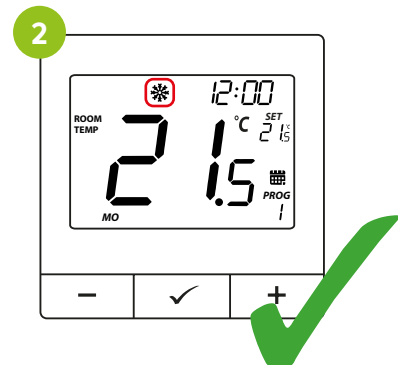

The icon will disappear from the controller's display, and the icon will appear. The system type has been changed from heating to cooling.

Attention:

To switch back to the heating system type, press and hold the - and ✓ buttons simultaneously for 3 seconds.

7.6 Key lock function

To LOCK the thermostat keys, follow the steps below:

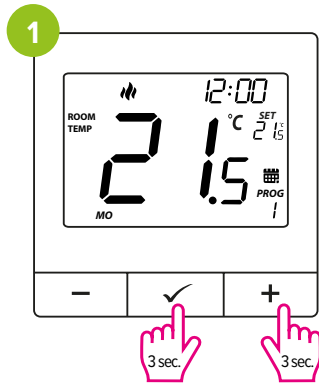

Press and hold ✓ and + buttons for 3 seconds.

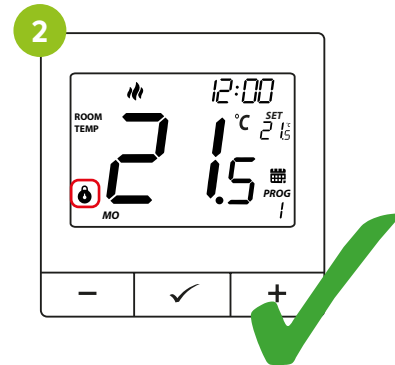

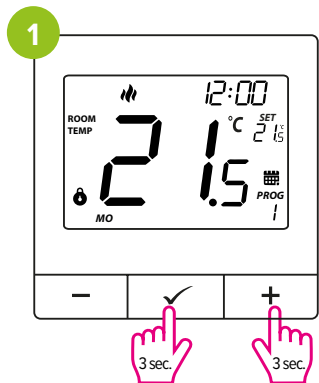

A  icon will appear on the screen.
The buttons on the thermostat have been locked.

To UNLOCK the thermostat keys, follow these steps:

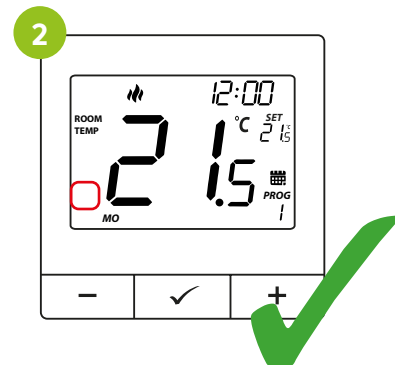

Press and hold ✓ and + buttons for 3 seconds.



The  icon will disappear from the screen.
The buttons on the thermostat have been unlocked.

Attention:

The user can protect the installer settings with a PIN code by activating parameter P07 (set to YES).

Next, in parameter P08, a new PIN code must be set.

To require the PIN code also when unlocking the controller's keys, parameter P09 must be activated (set to YES).

Attention:

Parameter P11 is functional only when P07 = YES.

Once this feature is activated, the user will be required to enter the PIN code each time to unlock the controller's keypad.

8. ZigBee thermostat installation without application - OFFLINE

8.1 Adding the thermostat to the ZigBee network

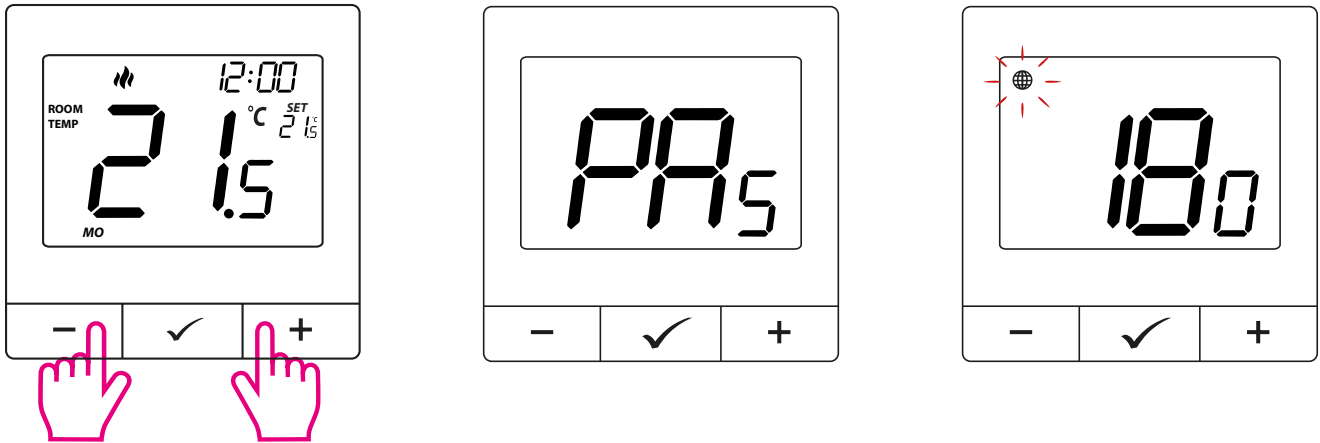

On the thermostat, hold down the - and + buttons simultaneously for 5 seconds until „PA” appears.
Release the keys. The thermostat will enter pairing mode.

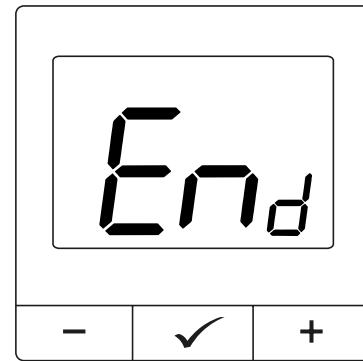
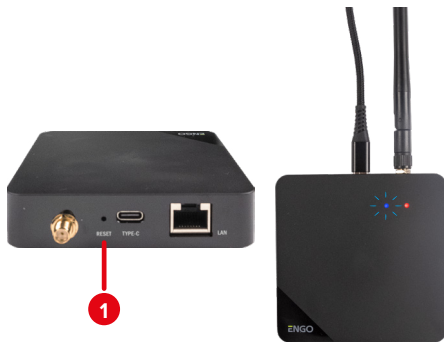

To start pairing mode, press the RESET button on the gateway. The blue LED will start flashing
- the ZigBee network is now open.

Once pairing is complete, the thermostat will display the message “End” on the screen.

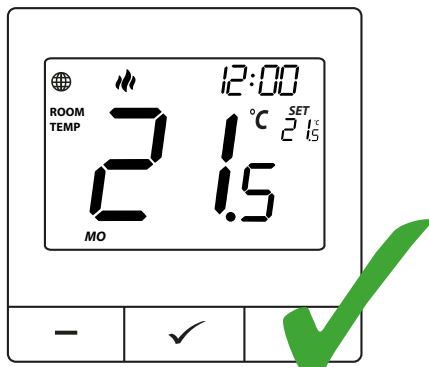

A globe icon will appear on the thermostat screen, indicating that it has been successfully added to the ZigBee network.



After adding all devices to the gateway, press the RESET button again to close the ZigBee network.
The blue LED will stop flashing.

8.2 ENGO Binding - wireless link between the thermostat and the receiver

The ENGO ZigBee series of devices - as the only one based on the TUYA platform - offers the so-called ENGO binding function, which enables direct linking of EONE, E40, E25 thermostats with receivers (ECB62-ZB control box, EMOD-ZB module, EREL-16ZB relay, EREL-12ZB relay) using the EGATE-PRO or EGATEZB universal gateway. This makes it possible to bind devices without having to create automation in the mobile application. The binding function ensures stable communication of the devices online and offline (even without Internet or router connection).

8.2.1 Linking the thermostat to the ECB62-ZB wireless control box

Ensure that the ECB62-ZB control box and the thermostat are on the same ZigBee network (they are added to the same Internet gateway) and the POWER LED on the control box is lit blue.

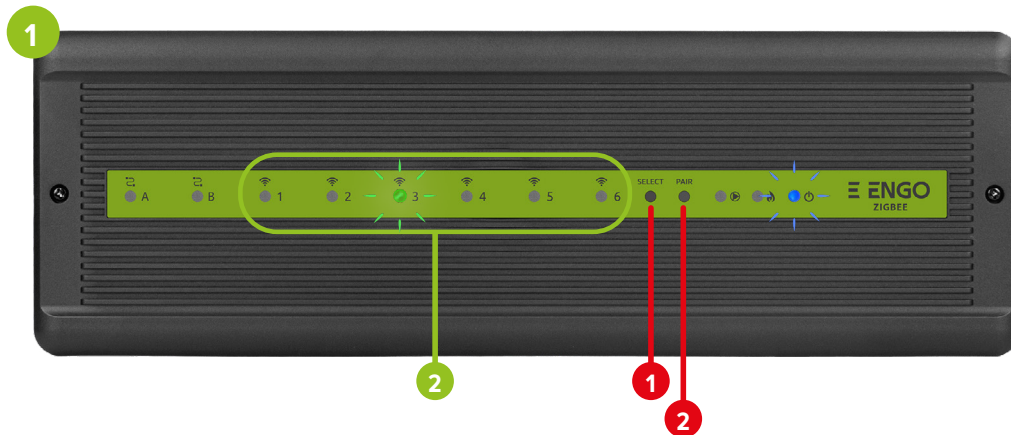

To correctly link the thermostat to the control box, first select the zone in the control box that you wish to assign to the thermostat using the SELECT button (1). The LED (2) will blink 3 times next to the selected zone. Confirm the selection by clicking on the PAIR button (2). The LED (2) will flash green next to the previously selected zone - The binding process has started, it is active for 10 minutes and during this time you can bind the thermostat to the selected zone.

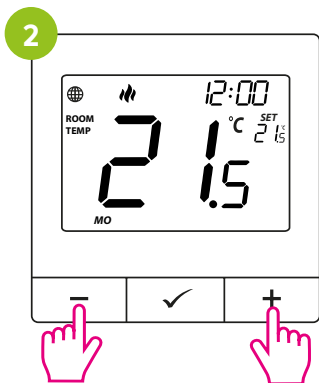

On the thermostat, hold down the - and + buttons simultaneously until the „bind” function appears.

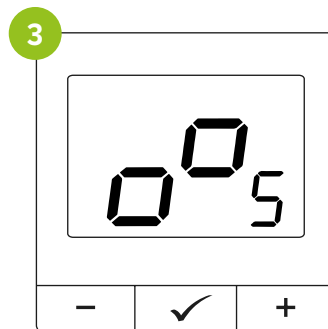

Release the keys, the bind function is active.

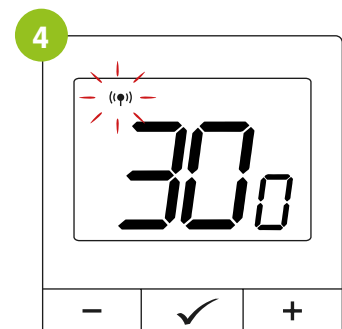

The „bind” process takes a maximum of 300 seconds.

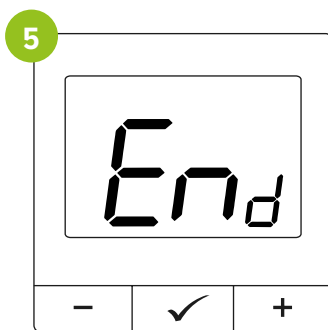

When the devices are paired correctly, the END message will be displayed.

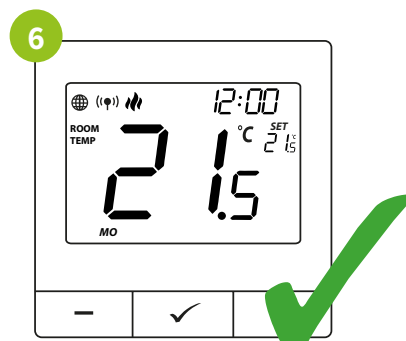

The devices have been paired correctly. The thermostat displays the main screen, the icon „(⚡)”, appears on the screen indicating the pairing with the receiver.



NOTES:

If the „bind” process fails, it must be repeated, taking into account distances between devices, obstacles and interference.



Remember:

The range can be increased by installing ZigBee network repeaters.



NOTES:

When the thermostat is binded with a wireless zone in the control box, in the event of a loss of communication between the devices, the zone will switch off after 50 minutes.

8.2.2 Linking the thermostat with the EMOD-ZB control module

Ensure that the module and the thermostat are on the same ZigBee network (are added to the same Internet gateway).



To correctly bind the thermostat to the module, first click the button quickly 5 times. The LED will start flashing slowly in red, indicating that the unit is in binding mode (pairing with the thermostat).

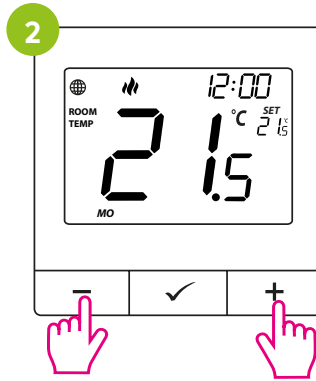

On the thermostat, hold down the - and + buttons simultaneously until the „bind” function appears.

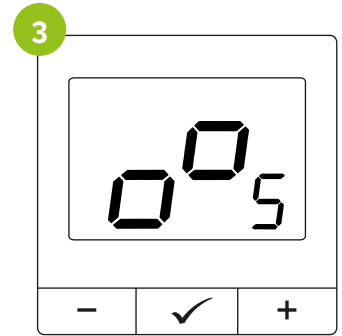

Release the keys, the bind function is active.

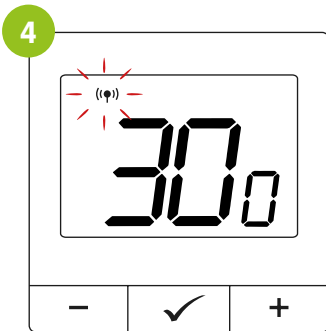

The „bind” process takes a maximum of 300 seconds.

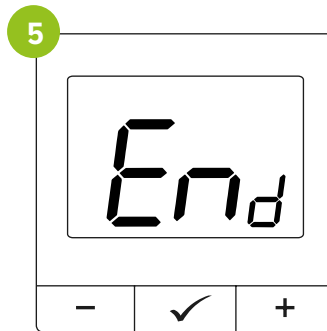

When the devices are paired correctly, the END message will be displayed. The LED on the module will stop flashing.

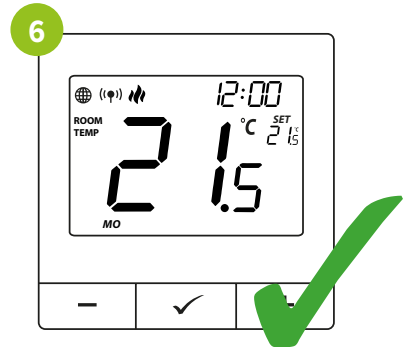

The devices have been paired correctly. The thermostat displays the main screen, icon " (⚡) " appears on the screen signalling the pairing with the receiver.



NOTES:

If the „bind” process fails, it must be repeated, taking into account distances between devices, obstacles and interference.



Remember:

The range can be increased by installing ZigBee network repeaters.



NOTES:

When the thermostat is binded with the module, in the event of a loss of communication between the devices, the module will switch off after 50 minutes.



NOTES:

When the thermostat is binded with the module, do not set time schedules in the module as these will interfere with the operation of the heating system.

8.2.3 Linking the thermostat to the EREL-16ZB, EREL-12ZB relay

Ensure that the module and the thermostat are on the same ZigBee network (are added to the same Internet gateway).

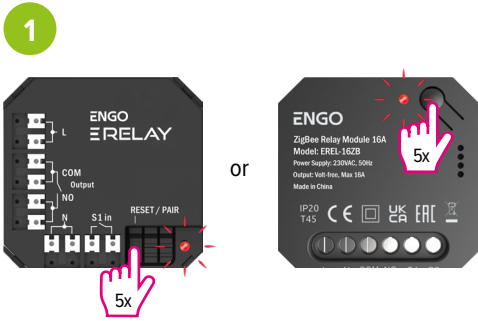

To correctly bind the thermostat to the module, first click the button quickly 5 times. The LED will start flashing slowly in red, indicating that the unit is in binding mode (pairing with the thermostat).

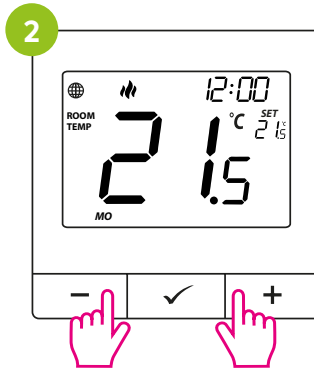

On the thermostat, hold down the - and + buttons simultaneously until the „bind” function appears.

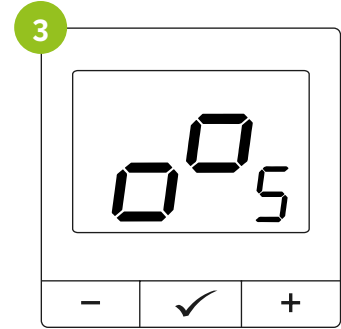

Release the keys, the bind function is active.

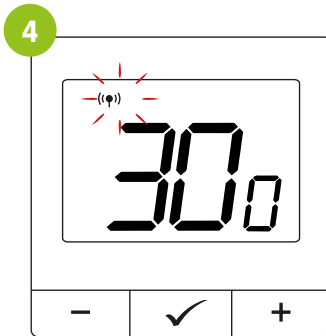

The „bind” process takes a maximum of 300 seconds.

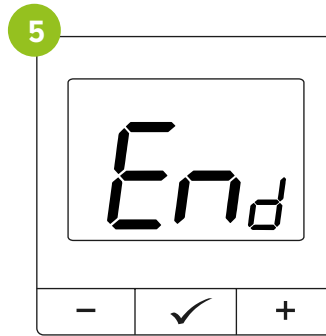

When the devices are paired correctly, the END message will be displayed. The LED on the module will stop flashing.

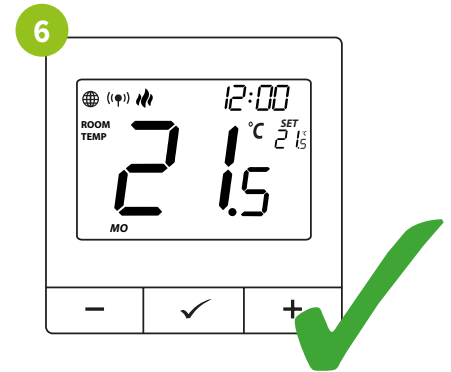

The devices have been paired correctly. The thermostat displays the main screen, icon ”(••)” appears on the screen signalling the pairing with the receiver.



NOTES:

If the „bind” process fails, it must be repeated, taking into account distances between devices, obstacles and interference.



Remember:

The range can be increased by installing ZigBee network repeaters.



NOTES:

When the thermostat is binded with the relay, in the event of a loss of communication between the devices, the module will switch off after 50 minutes.



NOTES:

When the thermostat is binded with the relay, do not set time schedules in the module as these will interfere with the operation of the heating system.

9. Controlling the radiator heating without the internet and apps

9.1 Operating principle of the radiator heating control

The wireless head is used to control radiator heating. An excellent replacement for the traditional manual thermostatic head. It needs to be paired with a master thermostat for it to work correctly. Up to 6 wireless heads can be paired with one thermostat within the same room. Two-way communication between the devices takes place every few minutes via radio. Based on the collected data, the thermostat modulates the opening of the head. The temperature measured by the thermostat ensures even heating of the entire interior. Using an internet gateway, it is possible to control the set (radiator head + regulator) using the ENGO Smart application.

9.2 Installing the TRV head on a thermostatic insert

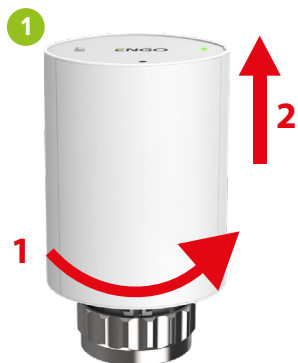

Remove the cover in a motion as shown.



Insert batteries according to polarity.

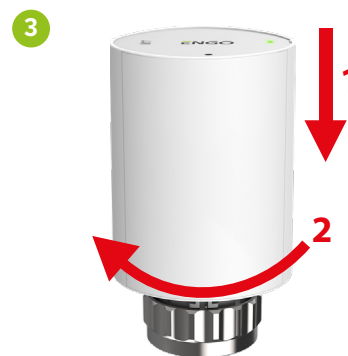

Fit the cover with the movement as shown.



An LED will indicate the software version (e.g. v3.5 flashing 3x green and 5x red).



Wait until the LED is lit continuously in green.

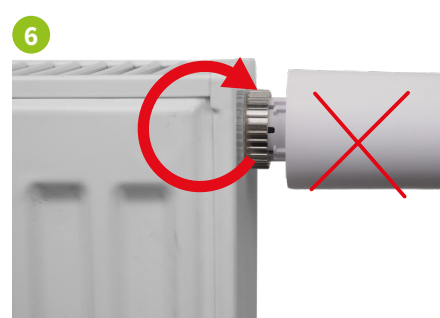

Screw the head onto the radiator valve by turning only the metal nut.

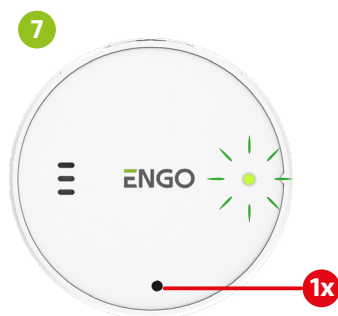

To start the adaptation process on the valve insert press the button once or wait 3 minutes, then the adaptation will start automatically. After correct adaptation - the LED will go out.

Mounting the head on the Danfoss RA valve

When mounting the head on the Danfoss RA valve (figure below), an adapter for M30 thread must be used.



INFO:

For the installation of the head on the Danfoss RA valve, contact customer service.

NOTES:

If there is an adaptation error with the valve insert, the LED will alternately flash green/red every 3 seconds. Check that the head is correctly mounted. Adaptation can be repeated immediately by clicking the button 1 time.

9.3 Synchronising the thermostat with the ETRV without an Internet gateway

An internet gateway is not required to synchronise the thermostat with the head. Ensure that the head is installed and adapted with the valve insert (see head manual).



After correct adaptation, press the button on the head for 3 seconds. The LED will start flashing blue.

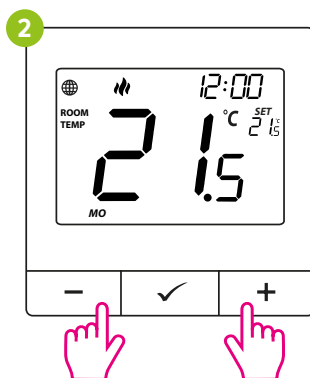

On the thermostat, hold down the - and + buttons simultaneously until the „SY” function appears.

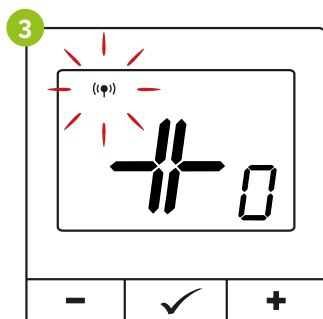
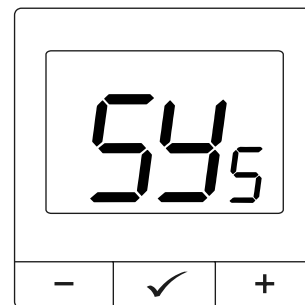

Release the keys, the SYNC function (synchronisation with the head) is active.



When the head is correctly synchronised with the thermostat, the LED on the head will light up blue for 10 seconds, then go out.

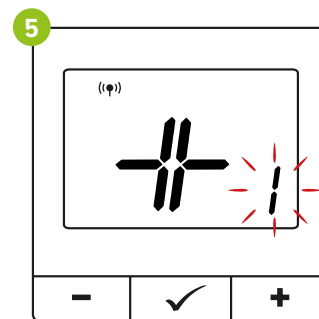

Once correctly paired with each head, the number of added heads in the bottom right corner of the screen will change.

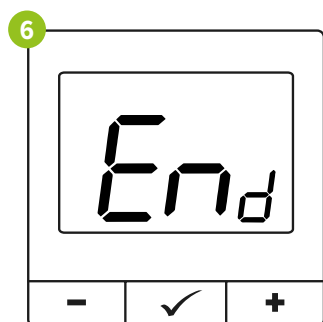

When the devices are paired correctly, the END message will be displayed.



The devices are paired and ready to go.

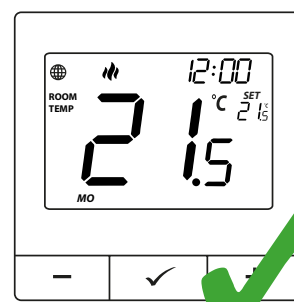

NOTES:

- If the thermostat is binded with a wireless control box or relay, it is not possible to start synchronisation.
- The synchronisation operation must be performed for each head separately. If you have made a mistake during pairing, paired the wrong head or performed the incorrect steps, REMEMBER that you can always perform a FACTORY RESET of the thermostat (see page 25) and perform the above steps again.
- If the devices (regulator and head) do not pair after 10 minutes, repeat the synchronisation process taking into account distances between the devices, obstacles and interference.

10. Installer parameters in OFFLINE mode

To enter installer parameters press and hold ✓ button for 3 seconds, then Select “PARA” with the - or + button and confirm with the ✓ button.

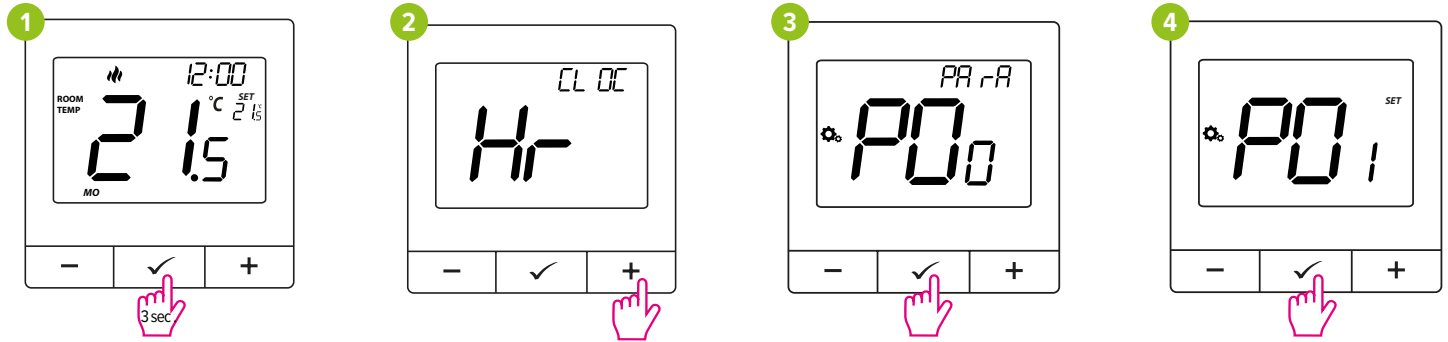

Use – or + button to move between parameters. Enter the parameter by ✓. Edit the parameter using – or + Confirm the new parameter value with the ✓ button.

Pxx	Function	Value	Description	Factory setting
P01	Select Heating/Cooling		Heating	
			Cooling	
P02	Method of control of heating/cooling system	TPI UFH	TPI algorithm for underfloor heating	TPI UFH for heating HIS 0.4 for cooling
		TPI RAD	TPI algorithm for radiator heating	
		TPI ELE	TPI algorithm for electric heating	
		HIS 0.4	SPAN +/-0.2°C	
		HIS 0.8	SPAN +/-0.4°C	
		HIS 1.2	SPAN +/-0.6°C	
		HIS 1.6	SPAN +/-0.8°C	
		HIS 2.0	SPAN +/-1.0°C	
P03	Correction of displayed temperature	-3.5°C to +3.5°C	If the thermostat indicates an incorrect temperature, it can be corrected within +/- 3.5°C	0°C
P04	Minimum set temperature	5°C - 45°C	Minimum heating/cooling temperature that can be set	5°C
P05	Maximum set temperature	5°C - 45°C	Maximum heating/cooling temperature, that can be set	35°C
P06	Display brightness	10% - 100%	Adjustable from 10 to 100%	50%
P07	Installer setting PIN	NO	Inactive	NO
		PIN	Active	
P08	PIN value	000-xxx	User PIN	000
P09	Required PIN to unlock keys (Active, when P07=PIN)	NO	No	NO
		YES	YES	
P10	Valve protection	ON	On	OFF
		OFF	Off	
P11	Soft available for heads	xxx	Software version available to update heads	Read
P12	Current soft in heads	null-xxx	null - soft in heads is current. xxx - newer version available, press ✓ to update heads	-
P13	ΔRCWC delta algorithm (for heads only)	0.5°C to 5.0°C	When the room temperature decreases/increases, the head opens in proportion to the size of the delta. The smaller the delta of the RCWC, the faster the response of the valve.	2.0
P14	Frost protection TRV	ON	On	ON
		OFF	Off	
P15	Internal relay	NO	Relay type NO-COM	NO
		NC	Relay type NC-COM	
		OFF	Relay disabled	
CLR	Return to factory settings	NO	Cancel	NO
		YES	Factory reset	

11. Factory reset

To RESET Thermostat to factory settings, hold down the – and + buttons until the „FA” message appears. Then release the keys. Then use the - or + button to change “NO” to „YES” and confirm with ✓ button. Thermostat will restart, will restore the default factory settings and display the main screen. If the thermostat has been added to an internet gateway and ZigBee network, it will be removed from the gateway and will need to be added / paired again.

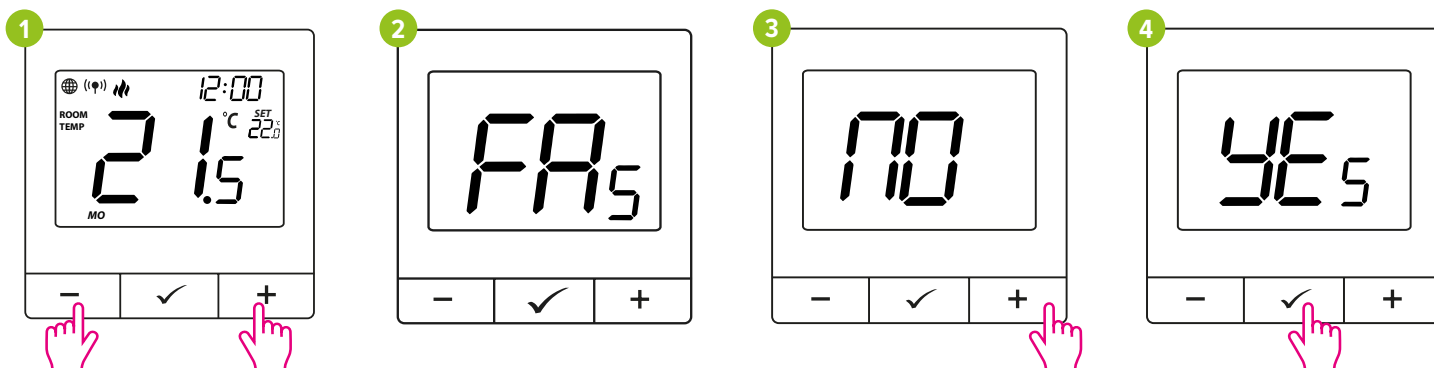

12. Communication map

12.1 Wired control of underfloor heating

- 1 **Internet gateway** - the main component for creating a wireless ZigBee network. It acts as an intermediary between ZigBee devices and a 2.4 GHz Wi-Fi or Ethernet router. With the gateway, it is possible to control ZigBee devices via a mobile app.
- 2 **Thermostat** - connected by wires to an executive device, such as a wired control box. Maintains the set temperature of the room, turning on or off the corresponding zone in the control box. Turns on the heating via the control box and activates the thermoelectric actuators mounted on the manifold. If the controller is used with an Internet-connected gateway, it is possible to control the temperature using the ENGO Smart mobile app.
- 3 **Wired control box** - connected to 230V power supply. Allows convenient connection and powering of wired controllers and actuators. It has the function of controlling the circulation pump and the boiler.
- 4 **Engo Smart mobile app** - allows remote control of smart devices in your home. It works with devices running under the Tuya cloud, making it extremely versatile and easy to use.

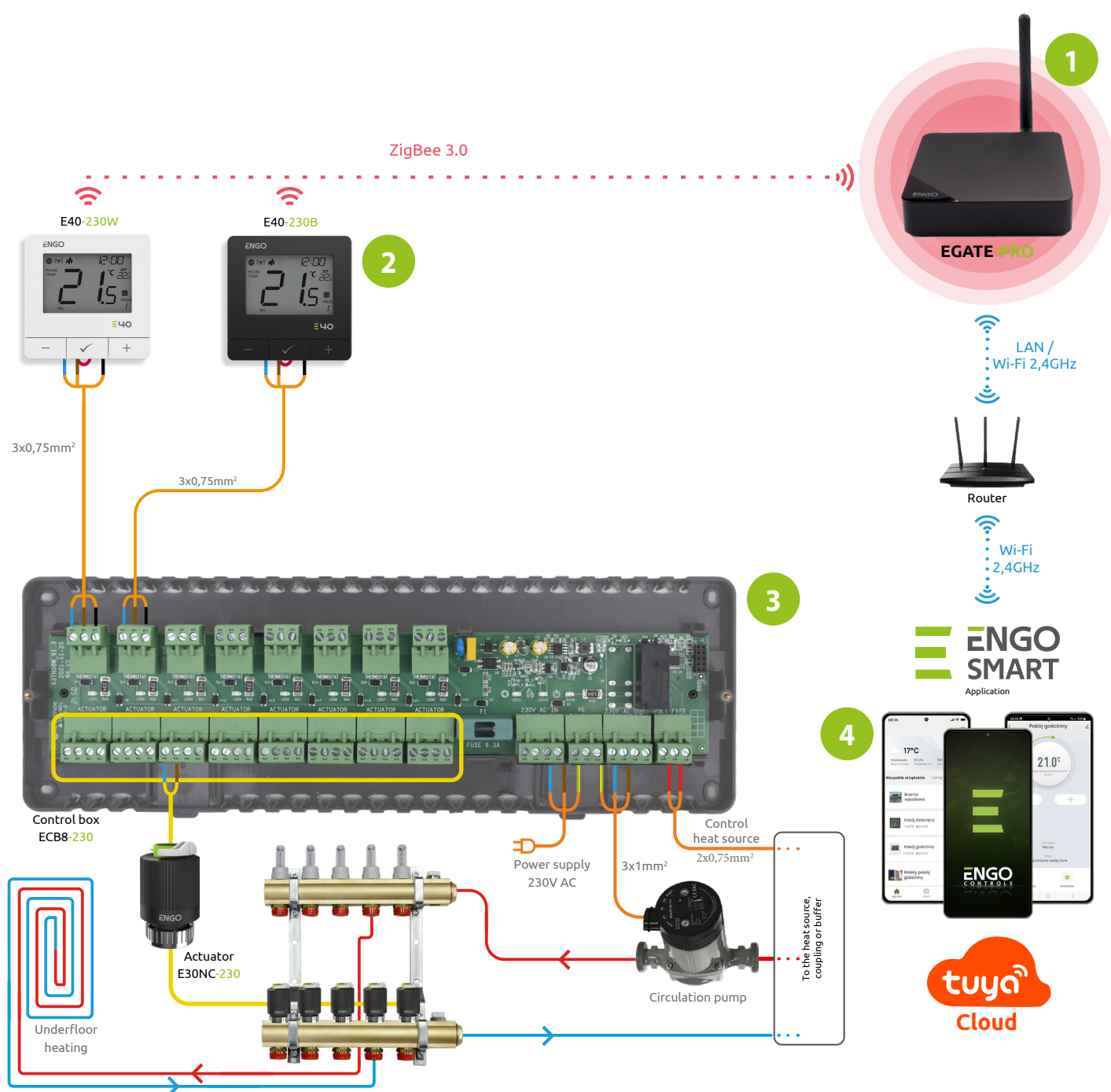

12.2 Wireless control of underfloor heating

- 1 **Internet gateway** - the main component for creating a wireless ZigBee network. It acts as an intermediary between ZigBee devices and a 2.4 GHz Wi-Fi or Ethernet router. With the gateway, it is possible to control ZigBee devices via a mobile app.
- 2 **Thermostat** - can be connected to the control box in two ways:
 - For zones "A" and "B" in the control box, make a wire connection (the controller can be powered from these zones).
 - For zones "1...6", the wireless „ENGO Binding" function is performed between the thermostat and the zone in the control box. Wireless binding is possible after the thermostat has been added to the gateway (to the ZigBee network). The thermostat maintains the set room temperature by switching the corresponding zone in the control box on or off, which activates the thermoelectric actuators mounted on the manifold. In addition, by connecting the gateway to the Internet and using ZigBee thermostats, the room temperature can be controlled using the ENGO Smart mobile app.
- 3 **Wireless control box** - allows control of 8 heating zones with a combination of connections: 2 wired and 6 wireless temperature thermostats. Wired control (zone "A" and "B") is done via a module plugged into the control box, which is linked wirelessly to the thermostat. Wireless communication is done using ZigBee 3.0 technology. The „ENGO binding" function provides wireless and direct linking of the control box (zones 1..6) to dedicated temperature thermostats using an internet gateway. The control box has a function to control the circulation pump and boiler.
- 4 **Engo Smart mobile app** - allows remote control of smart devices in your home. It works with devices running under the Tuya cloud, making it extremely versatile and easy to use.

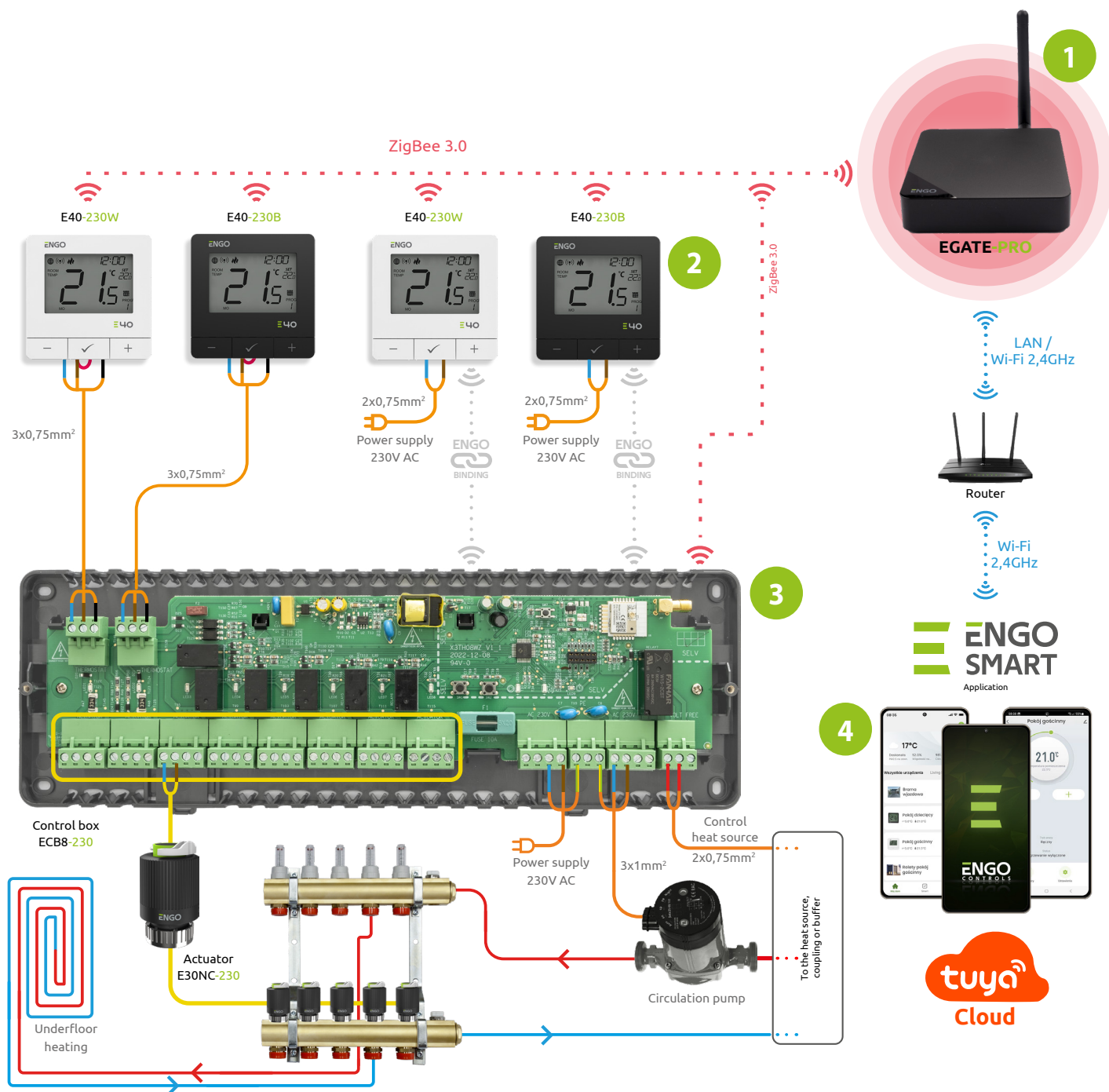

12.3 Wireless control of the radiator heating

- 1 **Internet gateway** - the main component for creating a wireless ZigBee network. It acts as an intermediary between ZigBee devices and a 2.4 GHz Wi-Fi or Ethernet router. With the gateway, it is possible to control ZigBee devices via a mobile app.
- 2 **Thermostat** - essential for the correct operation of the radiator heating. Two-way communication between the regulator and the head takes place every few minutes via radio. An internet gateway is not required to synchronise the thermostat with the head. If the thermostat is used with an internet gateway connected to the internet, it is possible to control the temperature using the ENGO Smart mobile app.
- 3 **Wireless head** - is used to control the radiator heating. In order for it to work properly, it is necessary to pair it with the master thermostat. Up to 6 wireless heads can be paired with one thermostat within the same room.
- 4 **Engo Smart mobile app** - allows remote control of smart devices in your home. It works with devices running under the Tuya cloud, making it extremely versatile and easy to use.
- 5 **Wireless relay** - allows you to control a heat source (such as a gas boiler) or a circulating pump. Wireless communication is carried out in ZigBee 3.0 technology using an Internet gateway.

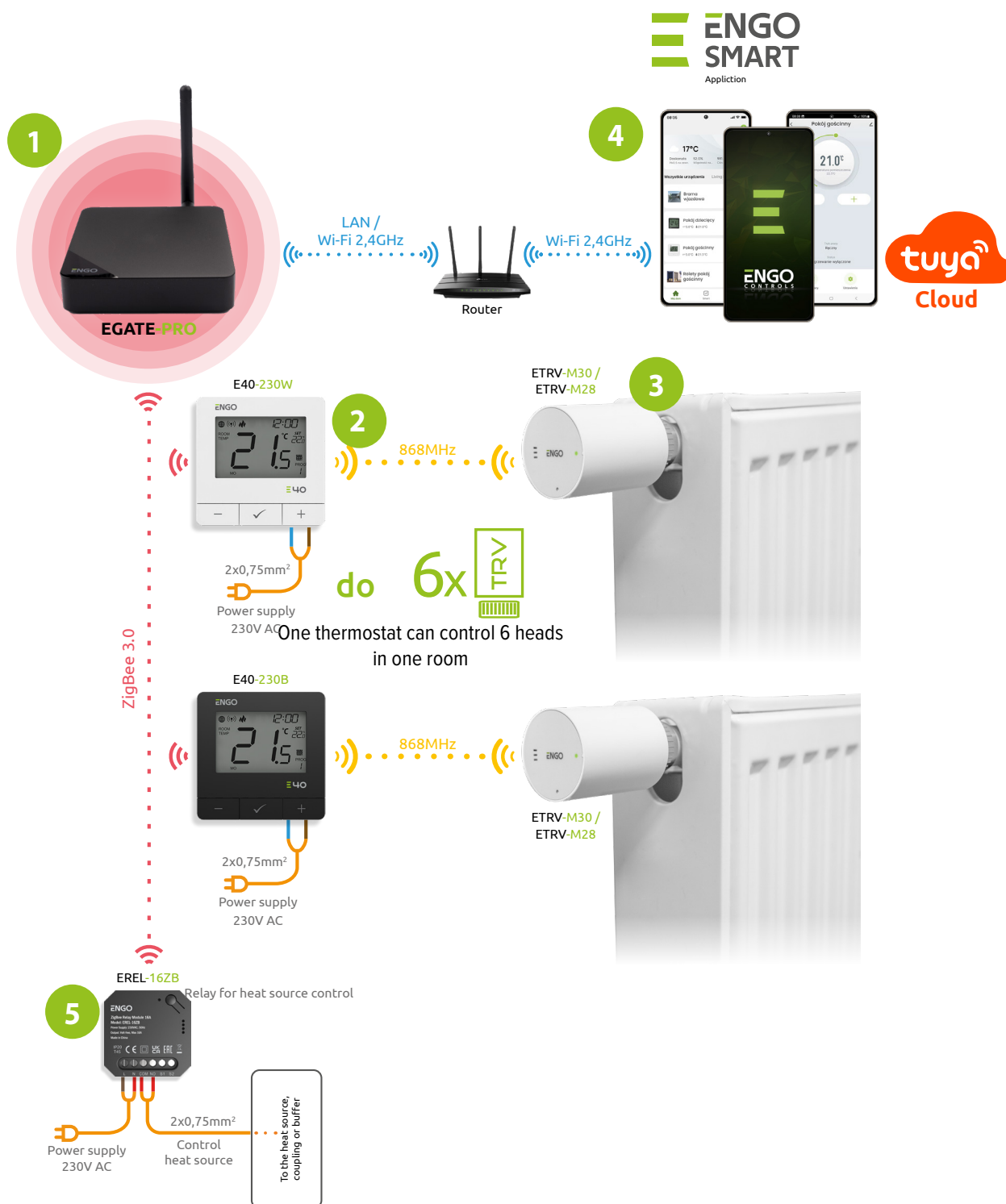

13. About ZigBee Network

13.1 ZigBee network creation and operation

ZigBee - is a wireless network based on the IEEE 802.15.4 standard, and communication takes place in the 2.4GHz band. The network is based on a mesh topology, which allows for a very long range and high reliability. The maximum range of direct communication between two network nodes (devices) is approximately 100m in open space.

The devices included in the ZigBee network are divided into three types:

- **coordinator** - only one such device can function in each network. It fulfills the role of a connection node for all devices

- **router (repeater)** - this device is powered by 230VAC, with functionality similar to classic network routers, and its task is to forward data packets and increase the range of the network

terminal device - battery powered, sends data to the coordinator (also through the router) to which it is connected. It is usually put to sleep temporarily, which helps reduce energy consumption. Built in security in the ZigBee protocol (ISO-27001 and SSAE16 / ISAE 3402 Type II - SOC 2 certification) ensure high transmission reliability, detection and removal of transmission errors, as well as connectivity between established priority devices.

Instructions on how to create a ZigBee
Mesh network
without interference from the Wi-Fi
signal



Installation of devices in the ENGO Smart Application

Download and install the ENGO Smart mobile app. You will find it in Google Play or the Apple App Store.



Before you start installing the system, make sure that:

- Bluetooth on your phone is ON
- Localization on your phone is ON
- Your phone is connected to a 2.4GHz Wi-Fi network with internet access.

To properly create a ZigBee Mesh network, add devices in the following order:

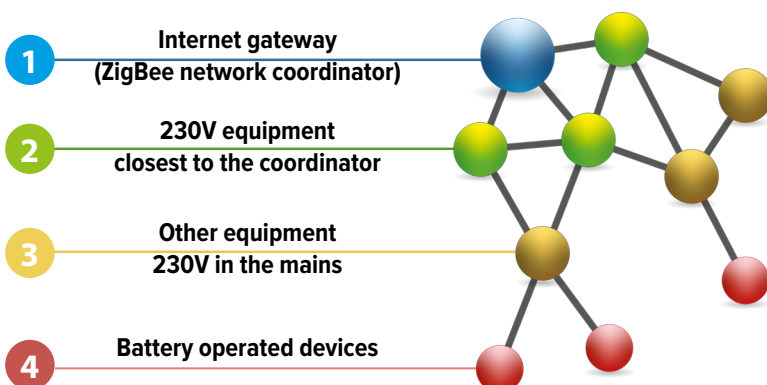

STEP 1 Install EGATE-PRO or EGATEZB (ZigBee network coordinator) internet gateway

To avoid interference with Wi-Fi and ZigBee networks, the minimum distance between the router and the gateway should be 1 m.



The gateway will automatically adjust the ZigBee channel so that it does not overlap with the Wi-Fi network.

STEP 2 Install 230V AC equipment as close as possible to the gateway

This will extend the reach of the ZigBee network and create a radio route for the installation of further devices.

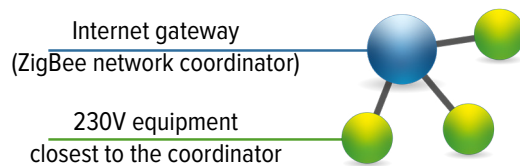

STEP 3 Install further 230V AC equipment

Installing further 230V AC voltage devices increases the range of ZigBee, creating a mesh network.

Increased range can also be achieved by installing network repeaters - EREPEATERZB.

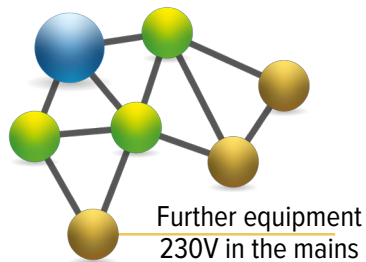

STEP 4 Install battery equipment

Installing battery devices is the final element of building a ZigBee Mesh network. Battery devices do not extend the range of the ZigBee network. To do so, use REPEATERS. Below is an example of a built network.

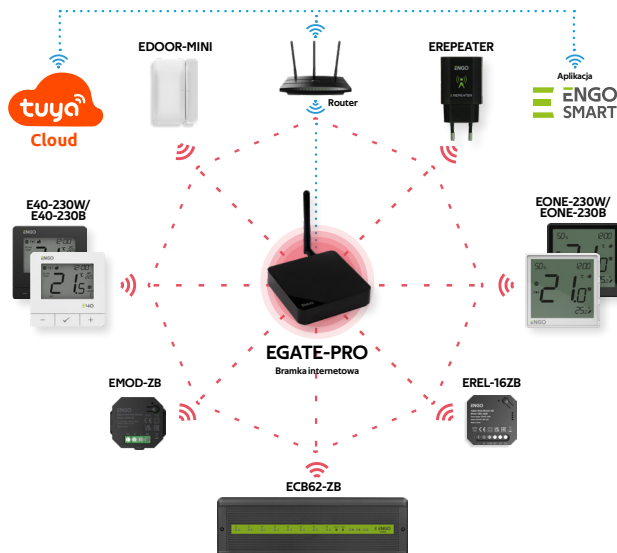

FOR THE ADVANCED USERS - Have you followed the instructions and still have problems with connectivity between ZigBee devices? Use the additional tips.

Arrange your 2.4 GHz Wi-Fi network channels

Wi-Fi and ZigBee channels operate on the same frequency - the 2.4 GHz band. Make sure that the Wi-Fi networks in your home do not operate on channels that overlap with the channel that the ZigBee gateway has selected.

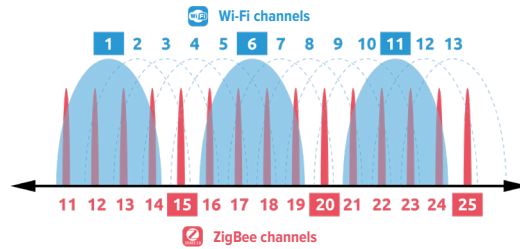

The figure below highlights the channels that interfere with each other. E.g. a Wi-Fi network operating on channel 6 interferes a lot with ZigBee channels 16, 17, 18, 19.

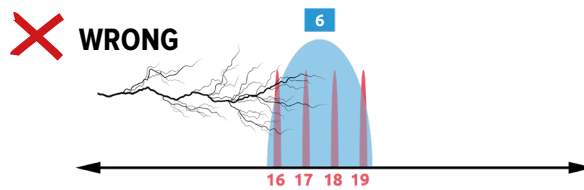

The further apart the ZigBee and Wi-Fi channels are, the better the operation of both networks will be - less risk of interference.

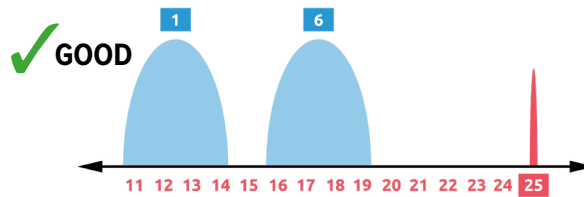

How do you find out what channels your Wi-Fi networks are running on?

Download an app on your phone, e.g. Wifi Analyzer (Wi-Fi network analyser), and use it to detect networks that are nearby on the 2.4 GHz frequency. On the graph, you will see the names of the Wi-Fi networks, the channels on which they are operating and the power with which they are transmitting.

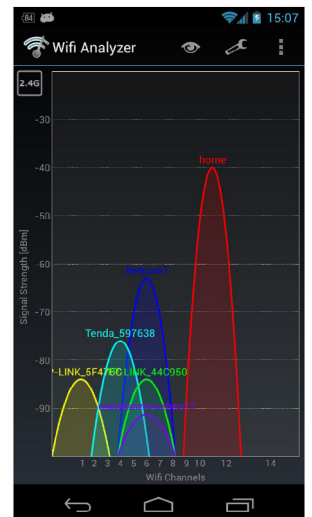

ZigBee channel settings

Remember that the ZigBee gateway automatically selects the best channel for itself. If you notice that your EGATE-PRO gateway has selected a channel that interferes with the Wi-Fi network channel, you can change it.

NOTES:

A change of the gateway channel is possible IF NO DEVICES ARE ADDED TO THE GATEWAY.

See how to change the ZigBee channel:

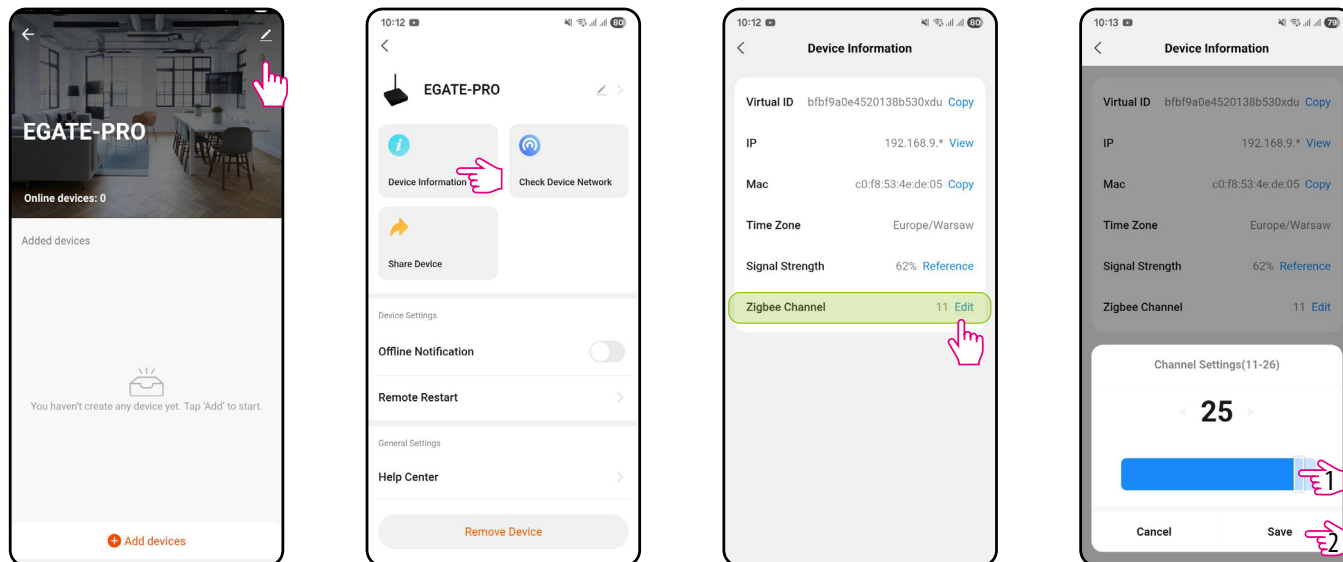

NOTES:

To change the channel of the EGATEZB gateway, disconnect it from the power supply and then reconnect it, it will automatically change to another channel. It is only possible to change the gateway channel IF NO DEVICES HAVE BEEN ADDED TO THE EGATEZB.

How do I set a fixed Wi-Fi channel for a 2.4 GHz network on my router? (Not an automatic channel).

Some routers themselves automatically change the Wi-Fi channels they operate on. That's why sometimes on the day of installation, ZigBee and Wi-Fi channels don't interfere with each other and the system works fine, only to start interfering after a while. We recommend that you change your router settings - so that Wi-Fi networks always work on a fixed channel - set as far away as possible from the channel the ZigBee gateway is working on.

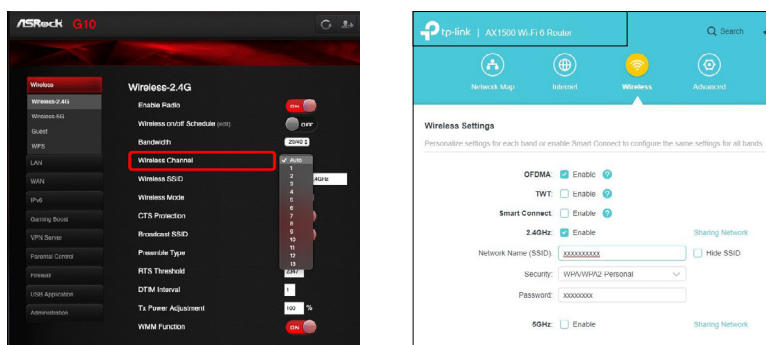

Summary - Solving disturbance problems

Many wireless devices are adjacent to each other. These devices operate on their own networks, which operate on unpredictable channels. Once your wireless network is up and running, you can easily detect the surrounding networks along with the channels they occupy. Special mobile apps - such as 'WiFi Analyzer', available for Android devices - serve this purpose.

1. Identify which channels are used by neighbours
2. Select the best channels for your Wi-Fi network
3. Conduct a bandwidth test of your Wi-Fi network to determine which channels your ZigBee network will overlap with
4. Deploy Wi-Fi networks on channels that will not interfere with ZigBee networks

14. About ENGO Smart

14.1 Mobile device requirements

FOR ANDROID MOBILE DEVICE:

Android version 5.0 or higher

FOR IOS MOBILE DEVICE:

IOS version 9.0 or higher

14.2 About ENGO Smart App (general information)

At the heart of the ENGO system is its ENGO Smart application. It allows the functionality of multiple devices to be combined in an affordable way. It allows you to connect to devices marked with the logos „Powered by Tuya” or „Powered by Tuya: Intelligence Inside”.

Remote control is via the Tuya cloud, which connects to the user’s phone, so that the user of the device does not have to rent a server room or deal with writing software for it. Why couldn’t the phone connect directly to the device? Such a necessity is because it would require a suitable router with a fixed IP address, so a mobile network would not work, and even having such a router, its configuration would be quite complicated and require some sacrifices as to the security of the link, as you would have to allow devices from outside the home to connect to it.

The initial connection and configuration can be done manually according to the step-by-step instructions displayed in the app, but there is also an option to automatically scan for configurable devices. Once this is done, the device automatically connects to the app and is visible in the list.

Each device you own can optionally be assigned to the room it is in, making it easier to discern if your home is truly smart. All devices, whether they belong to specific rooms, are assigned to one of the houses, of which you can have more than one. This assignment is not pointless, as the app knows where the device is located and can provide information about the current weather.

With this data, it is possible to create so-called scenes, i.e. automate repetitive activities and thus save time. For example, you can set the app to switch on the heating if the temperature drops below fifteen degrees, or to switch on the light when the sun goes down.

But what if you need to automate something independent of the weather? The ENGO app also caters for this need, and does so with scenes that can be triggered with a single click or that turn on when the status of one of the added devices changes. Example: you leave the house and want the power cut off from the smart socket to which the iron is connected, and five minutes after that, all the lights in the house are switched off. This can easily be set up and activated with a single click. Similarly, it is straightforward to solve the problem of lights going out in the bedroom - if the bedside lamp is switched on, the bedroom light can be set to go out.

14.3 Compatibility of devices in the ENGO SMART application

ZigBee devices:



EGATE-PRO



EGATE-ZB



ECB62-ZB



EONE-230W / EONE-230B
EONE-BATW / EONE-BATB



E40-230W / E40-230B
E40-BATW / E40-BATB

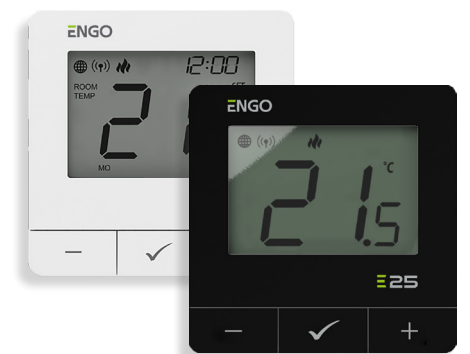

E25-230W / E25-230B
E25-BATW / E25-BATB



EDOOR-MINI



EBUTTON



EPIR



ELS



ESMOKE



EPLUG-ZB



EREL-12ZB



EREL-16ZB



EMOD-ZB



EROL-ZB



EREPEATER-MOD / EREPEATER



Wi-Fi devices:

Product presented on
SIMON 54 (DR1/49) frame



E10-W / E10-B



E55-W / E55-B

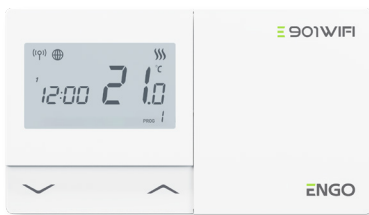

E901-WIFI



E20i-W / E20i-B



EREL-16WIFI



EROL-WIFI



EIRTX



EPLUG-WIFI



ECAM



ECAM-E27



ECAM-L1



ECAM-L2



ECAM-SOLAR

NOTES:

The ENGO Smart app is compatible with TUYA-enabled devices (e.g. smart light bulbs, intercoms, sensors, light switches).

15. ENGO Smart App instalation

DOWNLOAD THE ENGO SMART APP:



FOR AN ANDROID MOBILE DEVICE:

Method 1: Scan the QR code with your device scanner, download and install the app.

Method 2: Open the Google Play Store on your smartphone, search for and install the ENGO Smart application.

Requirements for mobile device Android:

Android version 5.0 or higher

FOR AN IOS MOBILE DEVICE:

Method 1: Scan the QR code and follow the directions to get to the AppStore, download and install the app.

Method 2: Open Apple's AppStore on your iPhone, search for the app ENGO Smart, download and install.

Wymagania dla urządzenia mobilnego z systemem IOS:

IOS version 9.0 or higher



Note: Enable storage / location / camera permissions during installation. Otherwise there may be problems during use / operation.

Note: Make sure your router is within close range of your mobile phone. Check that you have an internet connection. This will reduce the pairing time of your device.

REGISTER A NEW ACCOUNT:

To register a new account, please follow the steps below:

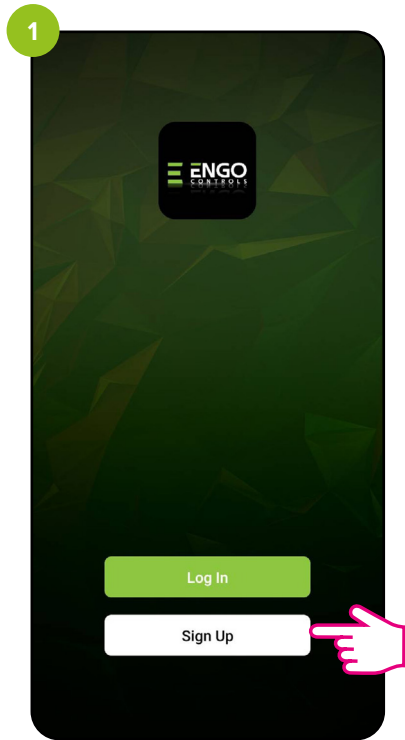

Click „Sign Up” to create new account.

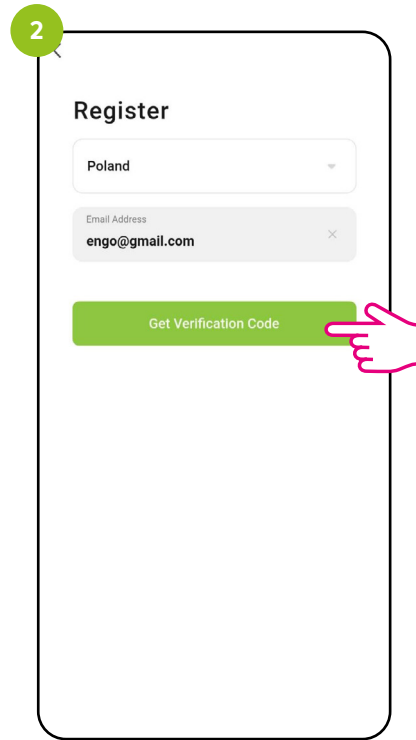

Enter your e-mail address to which the verification code will be sent.

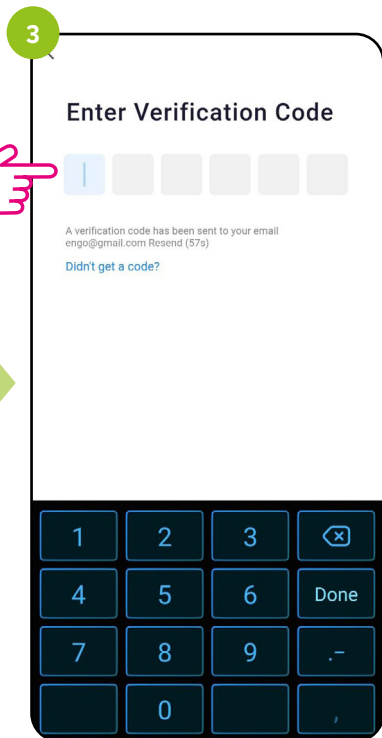

Enter the verification code received in the email.
Remember that you only have 60 seconds
to enter the code!

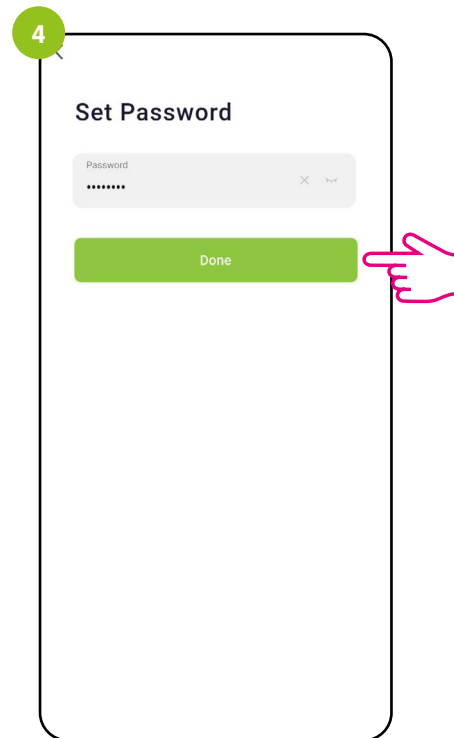

Then set the password for login.
The password must contain 6-20 characters
including letters and numbers.

FORGOTTEN PASSWORD:

If you have forgotten your password, you can log in as below:

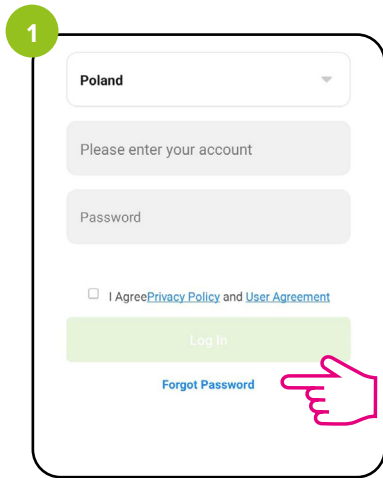

Click on „Forgot Password.”

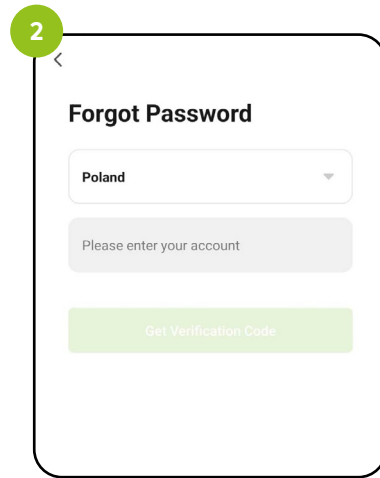

Enter the e-mail address used during account registration.

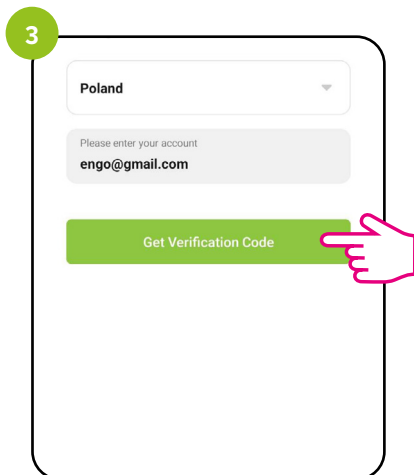

Click to receive the verification code to the email address you entered.

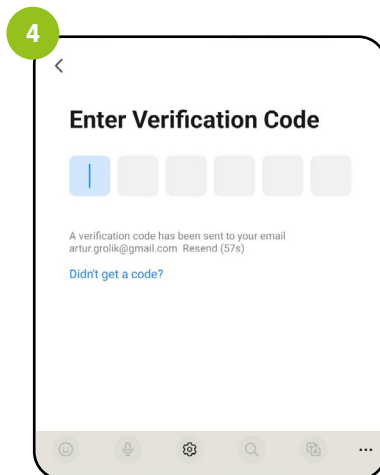

Enter the verification code received in the email. Remember that you only have 60 seconds to enter the code!

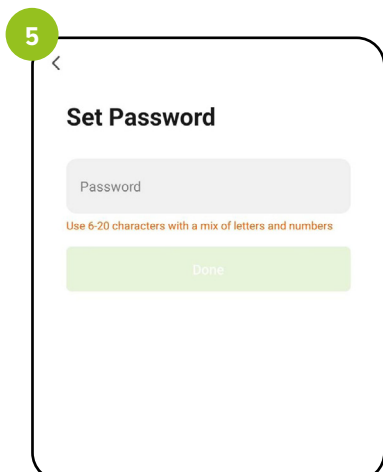

Set a NEW password for login. The password must contain 6-20 characters including letters and numbers.

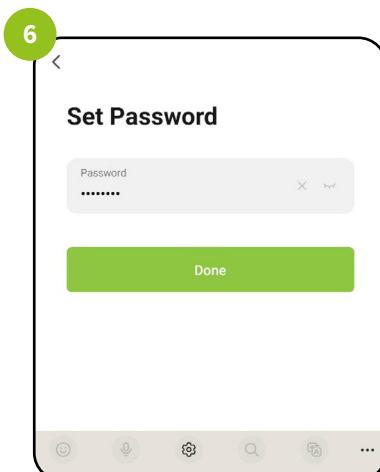

Once approved, you will be immediately logged into the application.

15.3 Guidelines for installing devices in a Wi-Fi network

- Make sure that the Wi-Fi network where you want to install the devices is broadcasting a signal in the 2.4 GHz frequency band.
- We recommend disabling mobile internet (cellular data) on your phone during setup.
- We recommend using WPA2-Personal encryption for the Wi-Fi network.

Parameters	Specification
Frequency band (GHz)	2.4GHz
WLAN standard	IEEE 802.11 b/g/n
Protocols	IPv4/IPv6/TCP/UDP/HTTPS/TLS/MulticastDNS
Security	WEP/WPA/WPA2/AES128
Security type supported	STA/AP/STA+AP

16. Installation of the ZigBee thermostat in the app - ONLINE



Ensure that a ZigBee gateway has been added to the application.

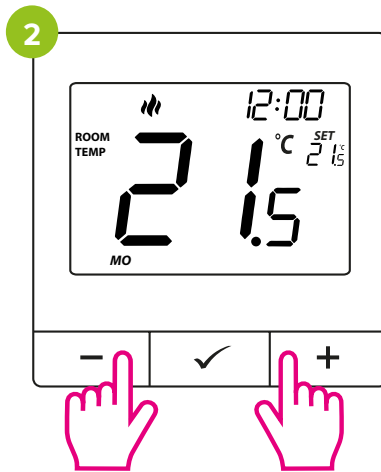

Ensure that a ZigBee gateway has been added to the application. On the thermostat, hold down the - and + buttons simultaneously for 5 seconds until "PA" appears. Release the keys. The thermostat will enter pairing mode.

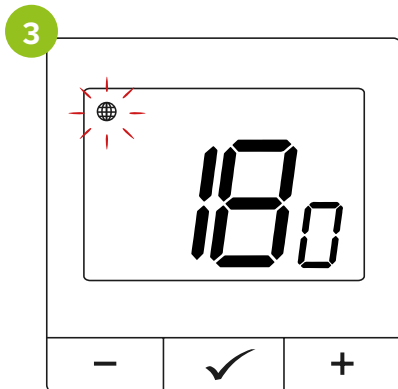
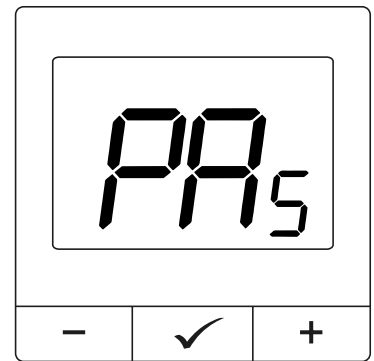

The thermostat counts down the time backwards (180s).

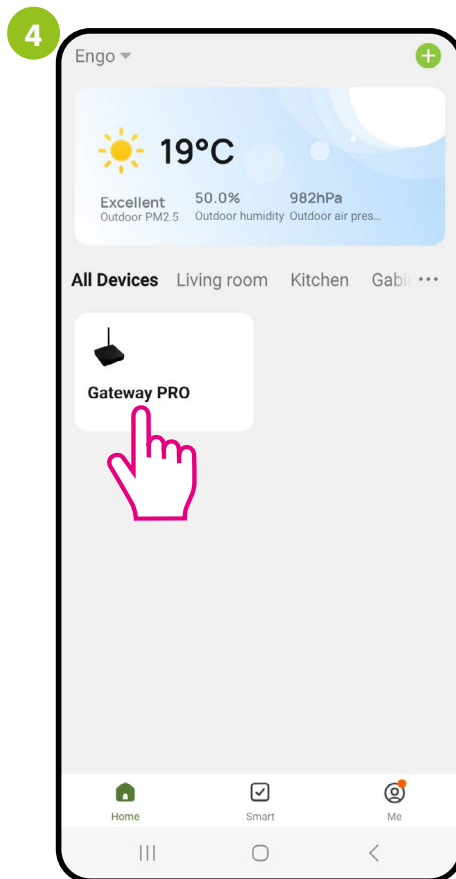

Enter the gateway interface.

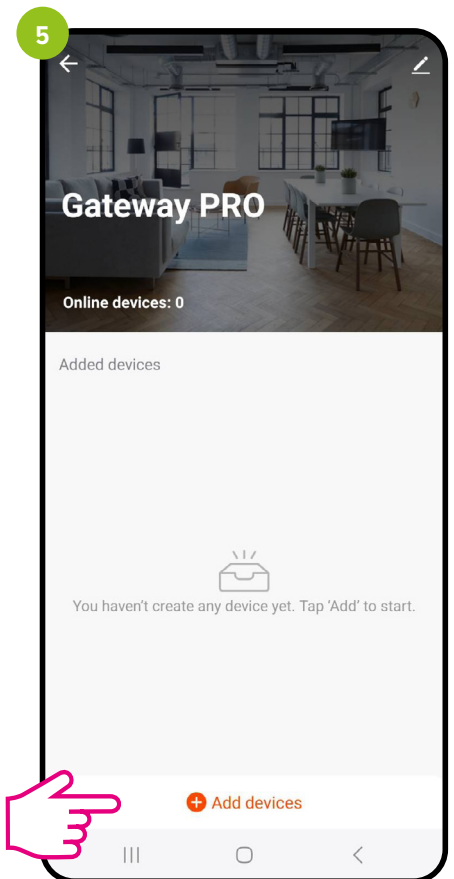

Add devices.

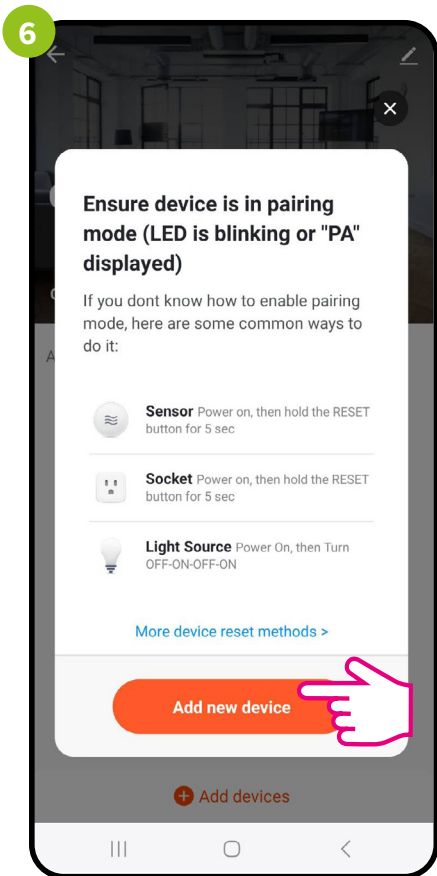

Click: "Add new device".

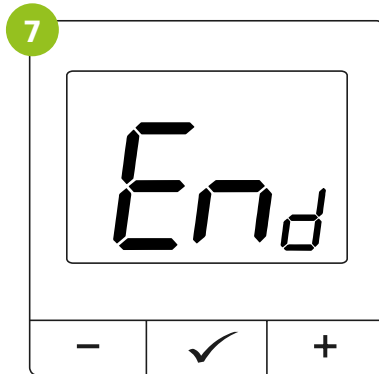

Wait for the End message.

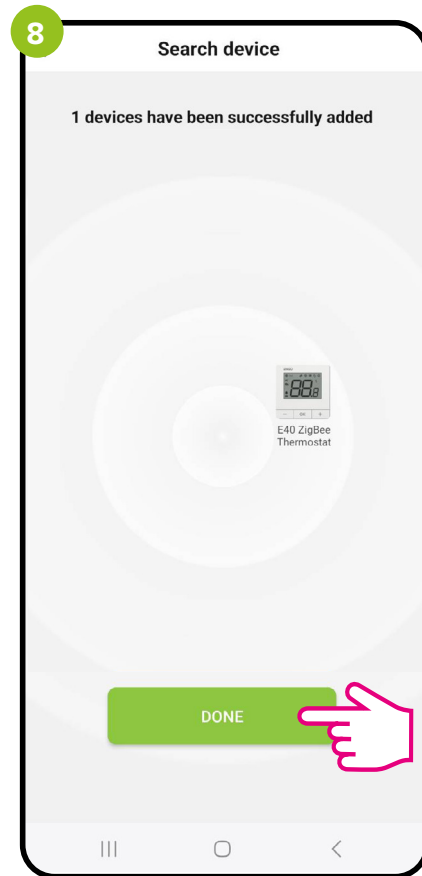

Then click: "Done".

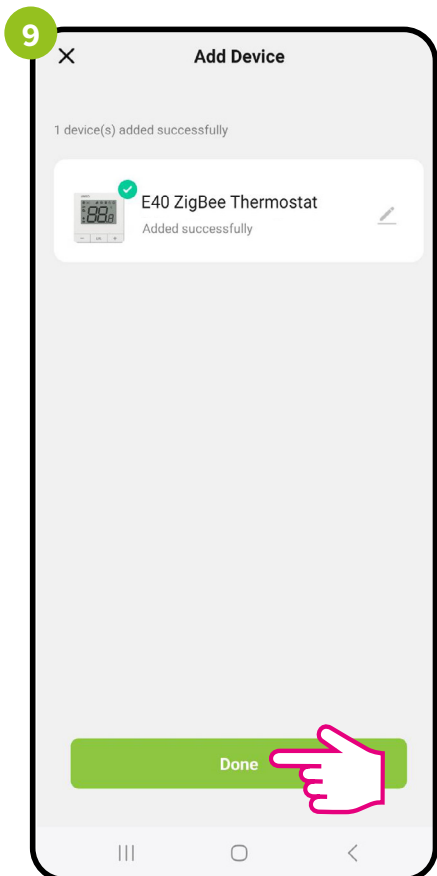

Name the device and click „Finish“.

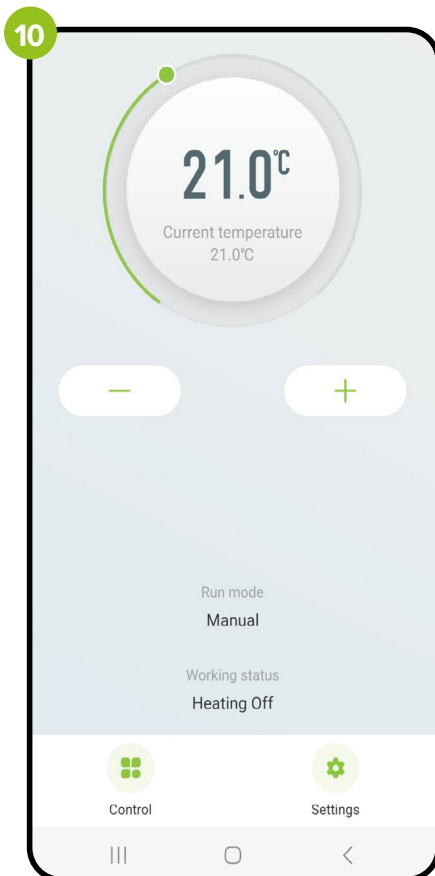

The thermostat has been installed and displays the main interface in the application.

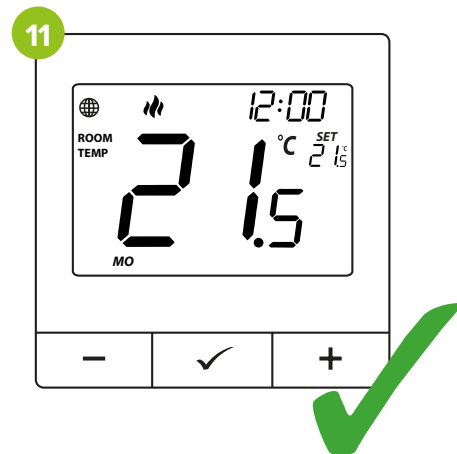

A globe icon appeared on the thermostat's screen indicating that it had been added to the ZigBee network.

17. ENGO Binding - wireless link between the thermostat and the receiver

The ENGO ZigBee series of devices - as the only one based on the TUYA platform - offers the so-called ENGO binding function, which enables direct linking of EONE, E40, E25 thermostats with receivers (ECB62-ZB control box, EMOD-ZB module, EREL-16ZB relay, EREL-12ZB relay) using the EGATE-PRO or EGATEZB universal gateway. This makes it possible to bind devices without having to create automation in the mobile application. The binding function ensures stable communication of the devices online and offline (even without Internet or router connection).

17.1 Linking the thermostat to the ECB62-ZB wireless control box

Ensure that the ECB62-ZB control box and the thermostat are on the same ZigBee network (they are added to the same Internet gateway) and the POWER LED on the control box is lit blue.

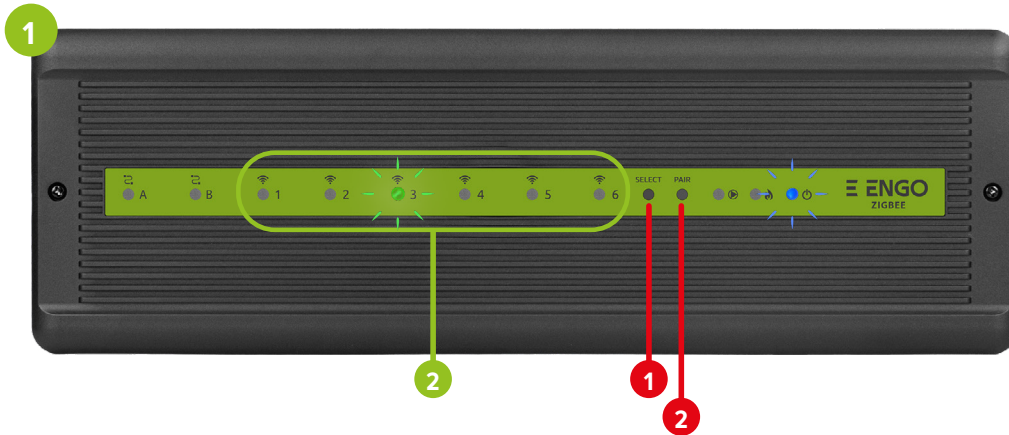

To correctly link the thermostat to the control box, first select the zone in the control box that you wish to assign to the thermostat using the SELECT button (1). The LED (2) will blink 3 times next to the selected zone. Confirm the selection by clicking on the PAIR button (2). The LED (2) will flash green next to the previously selected zone - The binding process has started, it is active for 10 minutes and during this time you can bind the thermostat to the selected zone.

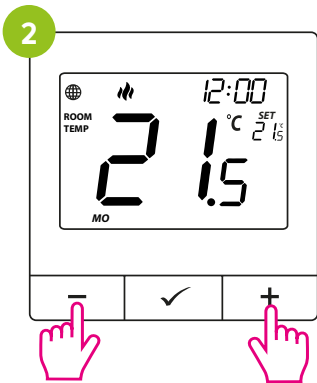

On the thermostat, hold down the - and + buttons simultaneously until the „bind” function appears.

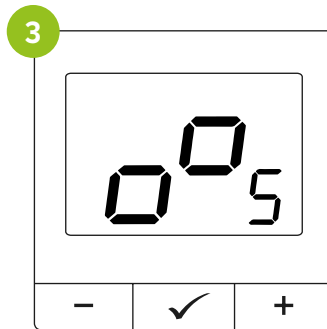

Release the keys, the bind function is active.

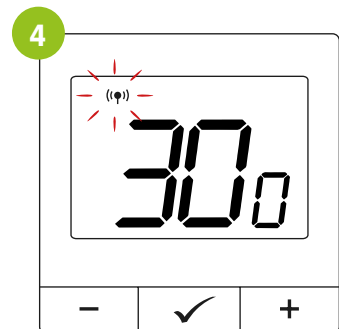

The „bind” process takes a maximum of 300 seconds.

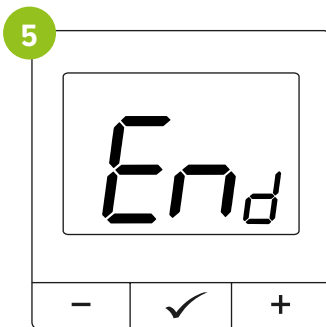

When the devices are paired correctly, the END message will be displayed.

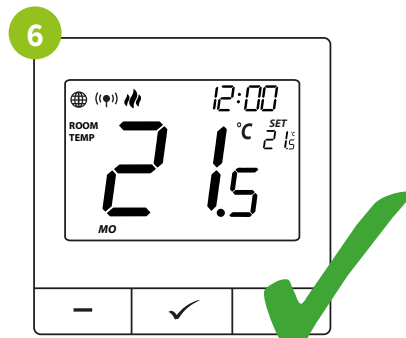

The devices have been paired correctly. The thermostat displays the main screen, the icon „⚡”, appears on the screen indicating the pairing with the receiver.



NOTES:

If the „bind” process fails, it must be repeated, taking into account distances between devices, obstacles and interference.



Remember:

The range can be increased by installing ZigBee network repeaters.



NOTES:

When the thermostat is binded with a wireless zone in the control box, in the event of a loss of communication between the devices, the zone will switch off after 50 minutes.

17.2 Linking the thermostat with the EMOD-ZB control module

Ensure that the module and the thermostat are on the same ZigBee network (are added to the same Internet gateway).



To correctly bind the thermostat to the module, first click the button quickly 5 times. The LED will start flashing slowly in red, indicating that the unit is in binding mode (pairing with the thermostat).

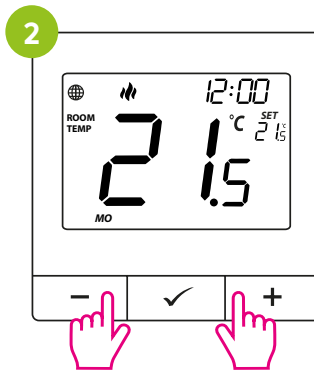

On the thermostat, hold down the - and + buttons simultaneously until the „bind” function appears.

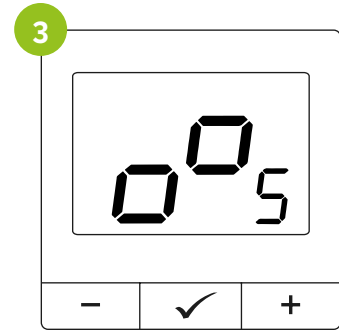

Release the keys, the bind function is active.

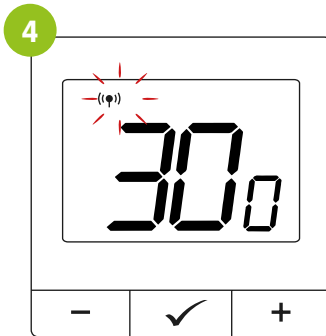

The „bind” process takes a maximum of 300 seconds.

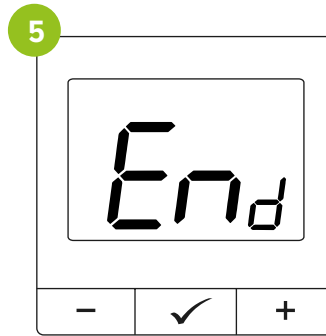

When the devices are paired correctly, the END message will be displayed. The LED on the module will stop flashing.

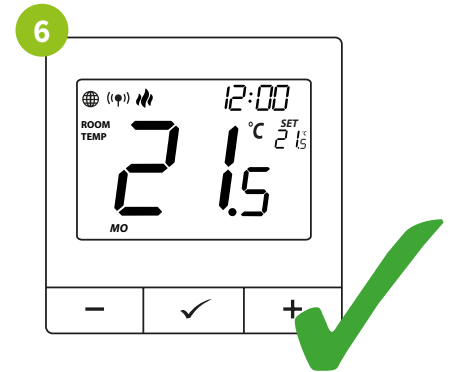

The devices have been paired correctly. The thermostat displays the main screen, icon " (⚡) " appears on the screen signalling the pairing with the receiver.



NOTES:

If the „bind” process fails, it must be repeated, taking into account distances between devices, obstacles and interference.



Remember:

The range can be increased by installing ZigBee network repeaters.



NOTES:

When the thermostat is binded with the relay, in the event of a loss of communication between the devices, the module will switch off after 50 minutes.



NOTES:

When the thermostat is binded with the relay, do not set time schedules in the module as these will interfere with the operation of the heating system.

17.3 Linking the thermostat to the EREL-16ZB, EREL-12ZB relay

Ensure that the module and the thermostat are on the same ZigBee network (are added to the same Internet gateway).

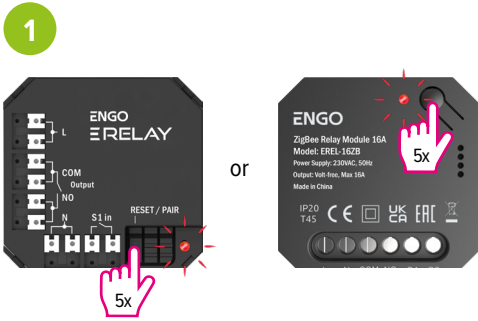

To correctly bind the thermostat to the module, first click the button quickly 5 times. The LED will start flashing slowly in red, indicating that the unit is in binding mode (pairing with the thermostat).

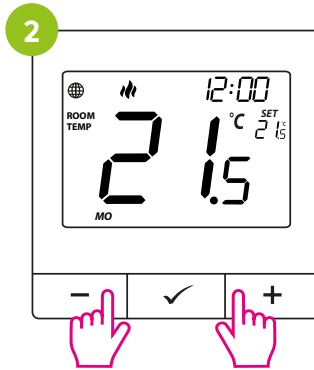

On the thermostat, hold down the - and + buttons simultaneously until the „bind” function appears.

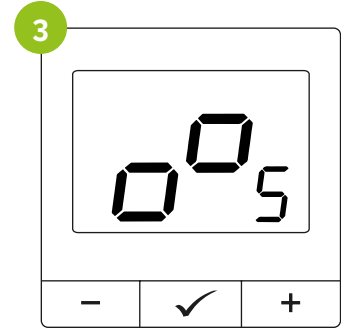

Release the keys, the bind function is active.

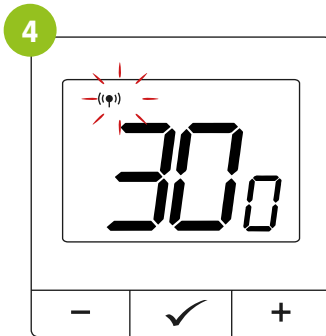

The „bind” process takes a maximum of 300 seconds.

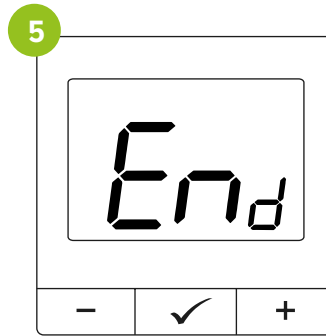

When the devices are paired correctly, the END message will be displayed. The LED on the module will stop flashing.

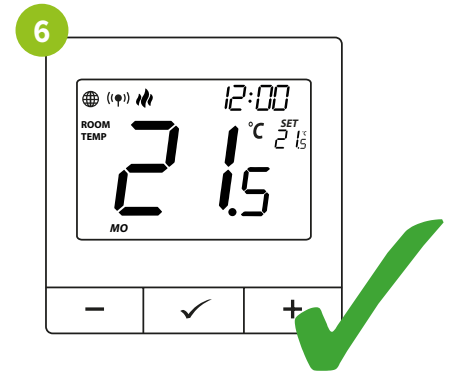

The devices have been paired correctly. The thermostat displays the main screen, icon "Ⓢ" appears on the screen signalling the pairing with the receiver.



NOTES:

If the „bind” process fails, it must be repeated, taking into account distances between devices, obstacles and interference.



Remember:

The range can be increased by installing ZigBee network repeaters.



NOTES:

When the thermostat is binded with the relay, in the event of a loss of communication between the devices, the module will switch off after 50 minutes.



NOTES:

When the thermostat is binded with the relay, do not set time schedules in the module as these will interfere with the operation of the heating system.

18. Controlling the radiator heating without the internet and apps

18.1 Operating principle of the radiator heating control

The wireless head is used to control radiator heating. An excellent replacement for the traditional manual thermostatic head. It needs to be paired with a master thermostat for it to work correctly. Up to 6 wireless heads can be paired with one thermostat within the same room. Two-way communication between the devices takes place every few minutes via radio. Based on the collected data, the thermostat modulates the opening of the head. The temperature measured by the thermostat ensures even heating of the entire interior. Using an internet gateway, it is possible to control the set (radiator head + regulator) using the ENGO Smart application.

18.2 Installing the TRV head on a thermostatic insert

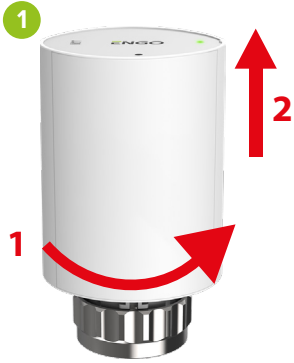

Remove the cover in a motion as shown.



Insert batteries according to polarity.



Fit the cover with the movement as shown.



An LED will indicate the software version (e.g. v3.5 flashing 3x green and 5x red).



Wait until the LED is lit continuously in green.

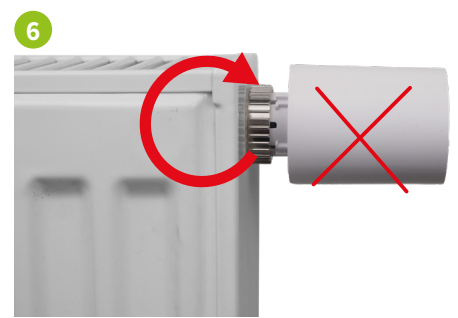

Screw the head onto the radiator valve by turning only the metal nut.

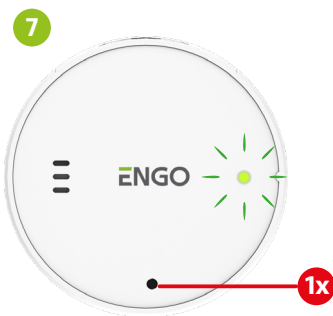

To start the adaptation process on the valve insert press the button once or wait 3 minutes, then the adaptation will start automatically. After correct adaptation - the LED will go out.

Mounting the head on the Danfoss RA valve

When mounting the head on the Danfoss RA valve (figure below), an adapter for M30 thread must be used.



INFO:

For the installation of the head on the Danfoss RA valve, contact customer service.

NOTES:

If there is an adaptation error with the valve insert, the LED will alternately flash green/red every 3 seconds. Check that the head is correctly mounted. Adaptation can be repeated immediately by clicking the button 1 time.

18.3 Synchronising the thermostat with the ETRV without an Internet gateway

An internet gateway is not required to synchronise the thermostat with the head. Ensure that the head is installed and adapted with the valve insert (see head manual).



After correct adaptation, press the button on the head for 3 seconds. The LED will start flashing blue.

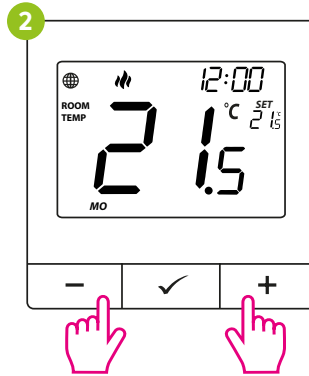

On the thermostat, hold down the - and + buttons simultaneously until the „SY” function appears.

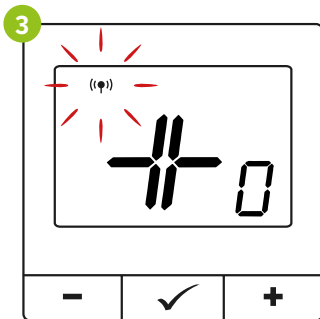
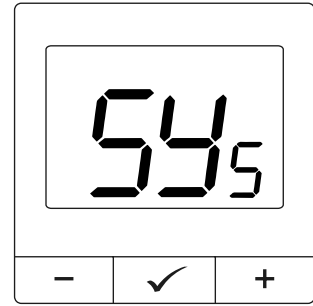

Release the keys, the SYNC function (synchronisation with the head) is active.



When the head is correctly synchronised with the thermostat, the LED on the head will light up blue for 10 seconds, then go out.

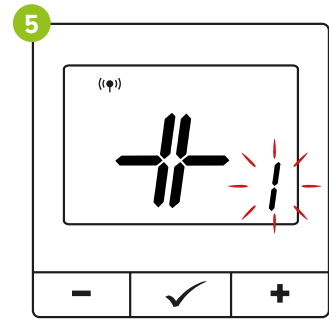

Once correctly paired with each head, the number of added heads in the bottom right corner of the screen will change.

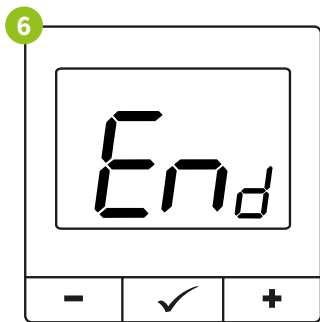

When the devices are paired correctly, the END message will be displayed.

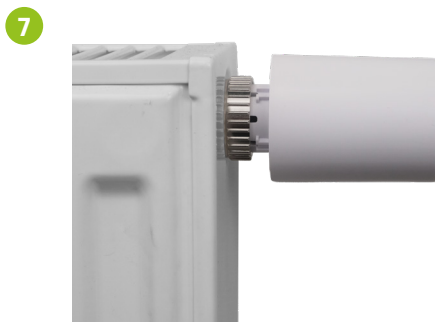

The devices are paired and ready to go.

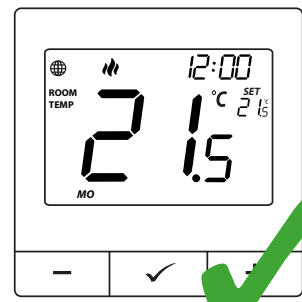

NOTES:

- If the thermostat is binded with a wireless control box or relay, it is not possible to start synchronisation.
- The synchronisation operation must be performed for each head separately. If you have made a mistake during pairing, paired the wrong head or performed the incorrect steps, REMEMBER that you can always perform a FACTORY RESET of the thermostat (see page 104) and perform the above steps again.
- If the devices (regulator and head) do not pair after 10 minutes, repeat the synchronisation process taking into account distances between the devices, obstacles and interference.

19. Thermostat operation in the app - ONLINE

19.1 General information

In this chapter you can learn how to use the ZigBee thermostat in combination with the ENGO Smart application. In order to control the regulator via the Internet, you will need a web gateway and the ENGO Smart app. Controlling the thermostat via the app from a mobile device (IOS, Android) gives you a lot of freedom and the possibility to remotely manage the temperature from anywhere.

19.2 Description of icons in the application

Menu view of the E40 thermostat in the ENGO Smart application



20. Control

20.1 Setpoint / temperature setting

The temperature setpoint is changed by moving the cursor left/right in the application. On the screen, the current temperature setpoint is represented by the number displayed in larger font.

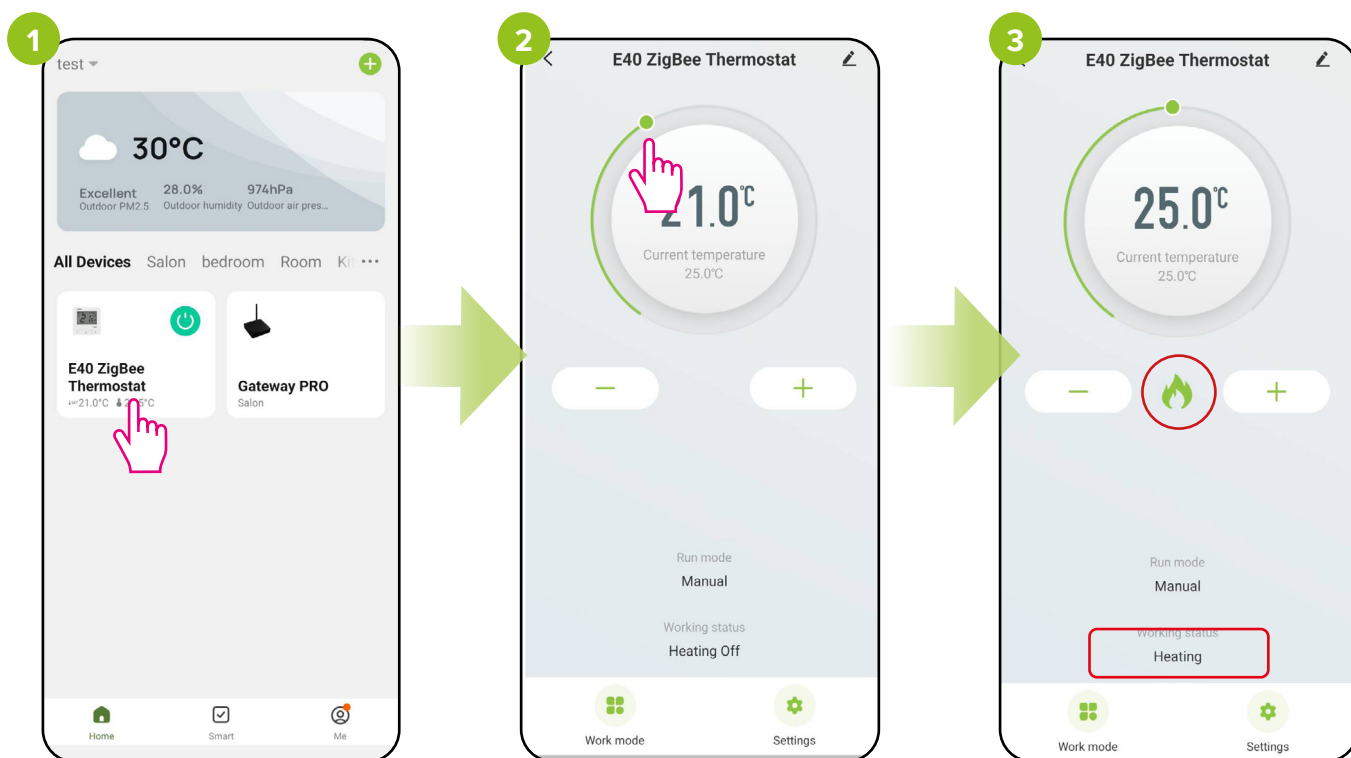

Enter the thermostat interface.

Make a new temperature setting by moving the dot across the bar.

The thermostat has started to send signal for heating signalling this by changing the status to "Heating" and the flame icon.

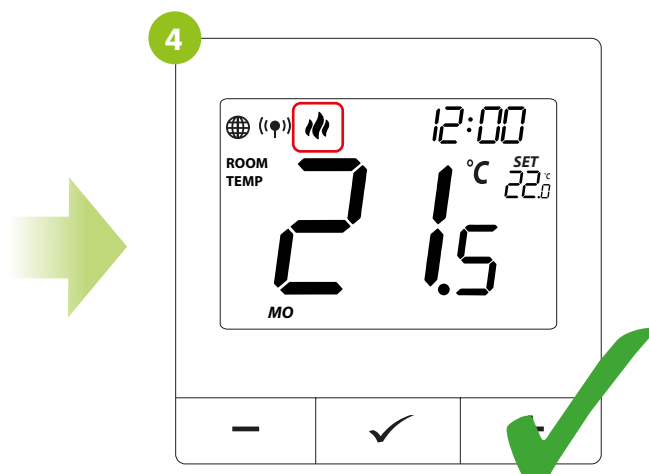

...and the heating icon starts animating on the device screen.

20.2 On / Off

In this option, the user can switch the thermostat on/off from the app. To do this, follow the steps below:

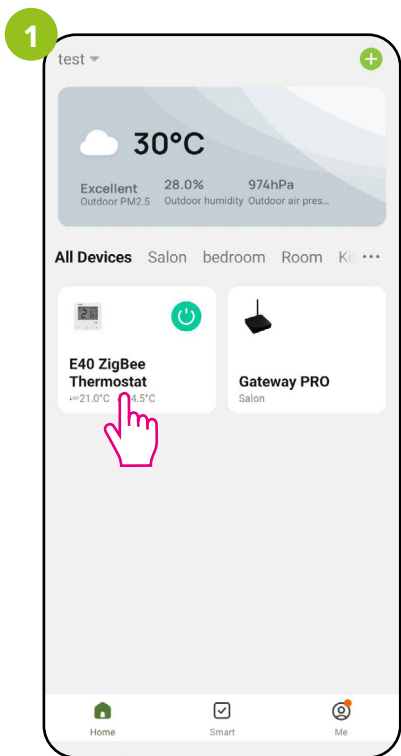

Enter the thermostat interface.

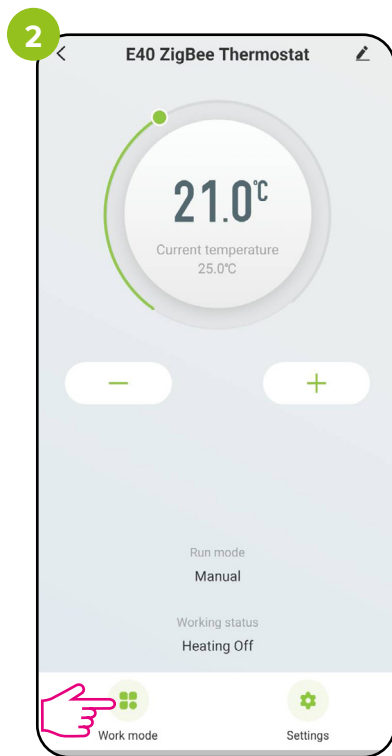

Select the „Work mode” option.

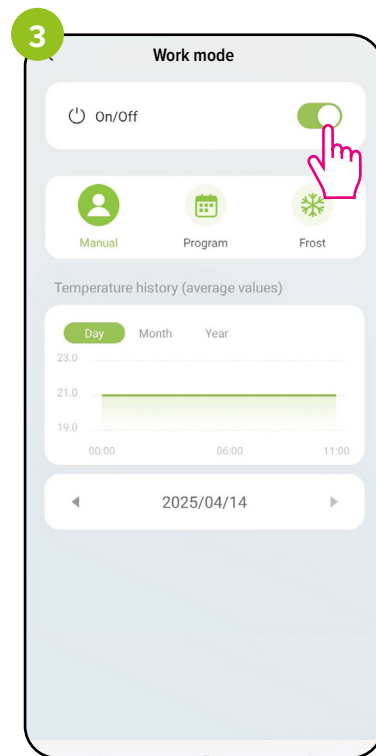

With the On / Off slider you can switch the thermostat on/off.

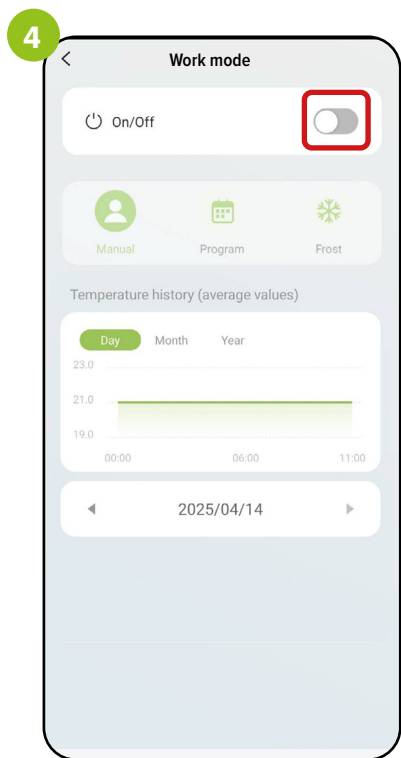

When the On / Off slider is greyed out, the thermostat is off ...

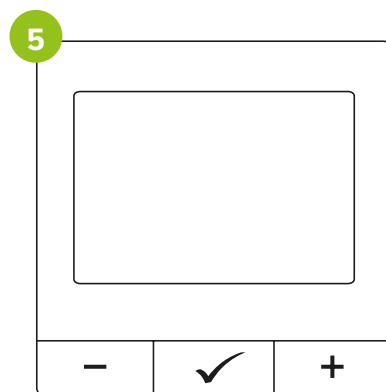

... and thermostat screen is blank.

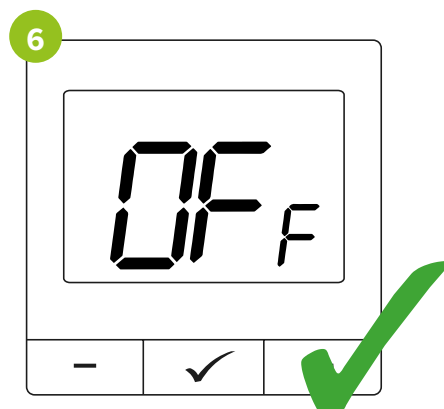

Press the thermostat button to illuminate the screen. The message „OFF” will appear, indicating that the thermostat is switched off. To switch the thermostat back on, move the ON/OFF slider from within the application or hold down the key on the thermostat for 5 seconds.

20.3 Manual mode

In manual mode, the thermostat will maintain the set temperature until the user changes it again from the app or the thermostat, or selects a new operating mode. To set the manual mode, follow the steps below:

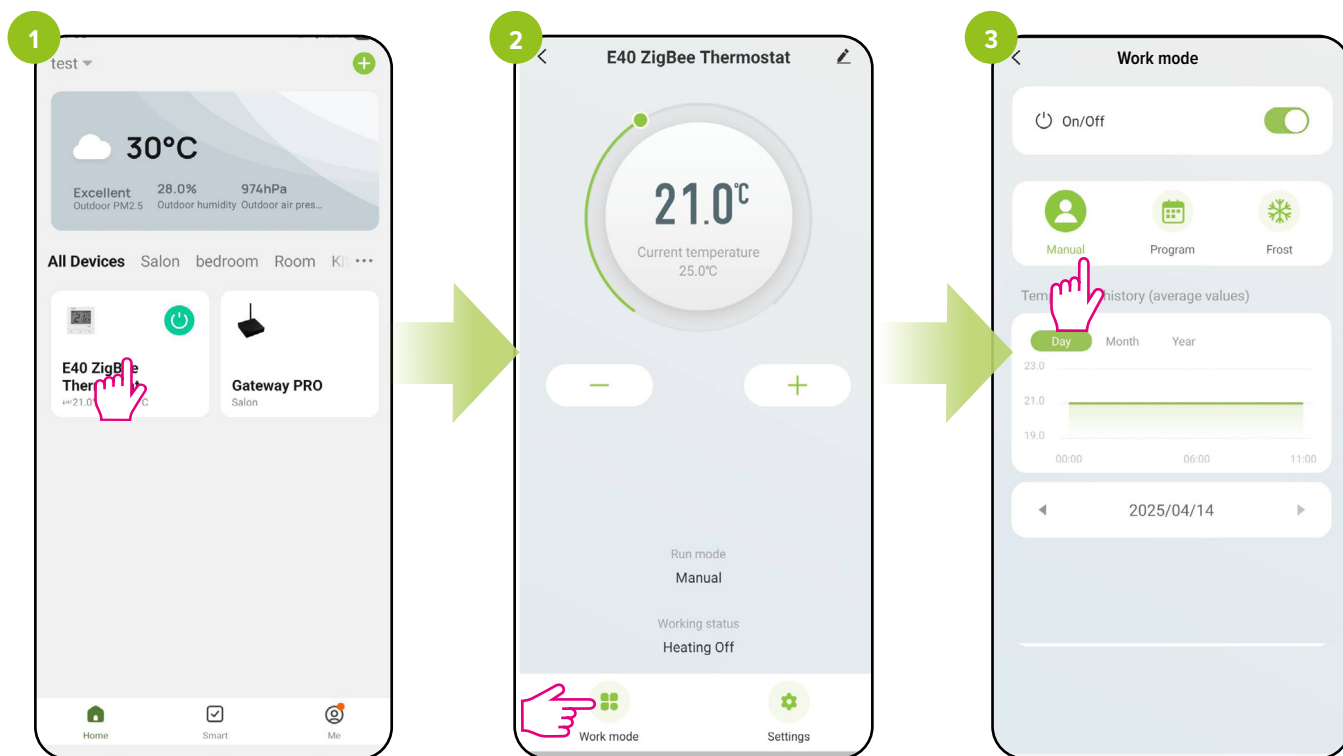

Enter the thermostat interface.

Select the „Work mode” option.

Select manual operation mode.

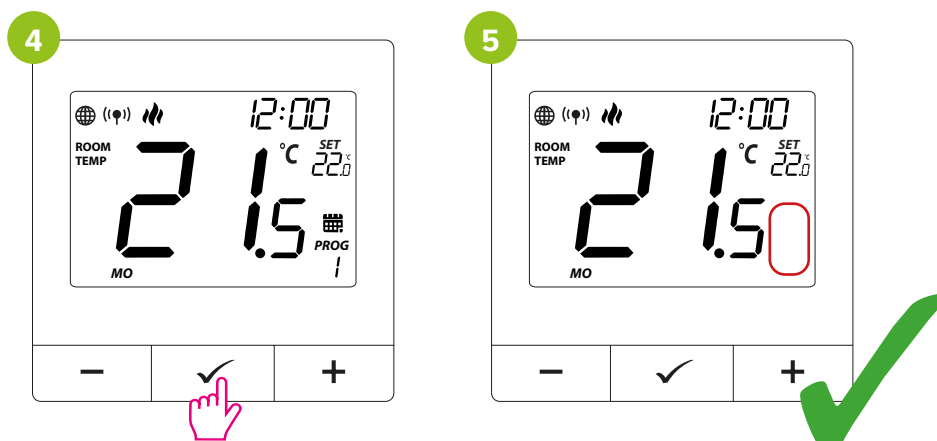

To change the mode from active schedule to manual mode, click the button. The schedule icon will disappear from the thermostat screen.

20.4 Schedule mode

The ZigBee thermostat allows you to set schedules. When creating a schedule, you specify the start time of the schedule together with the set temperature. A maximum of 4 switching points can be set for each day of the week.

To activate the schedule, press the schedule icon in the „Control” area. Once activated, the thermostat status will update to „Schedule”.

To activate schedule mode:

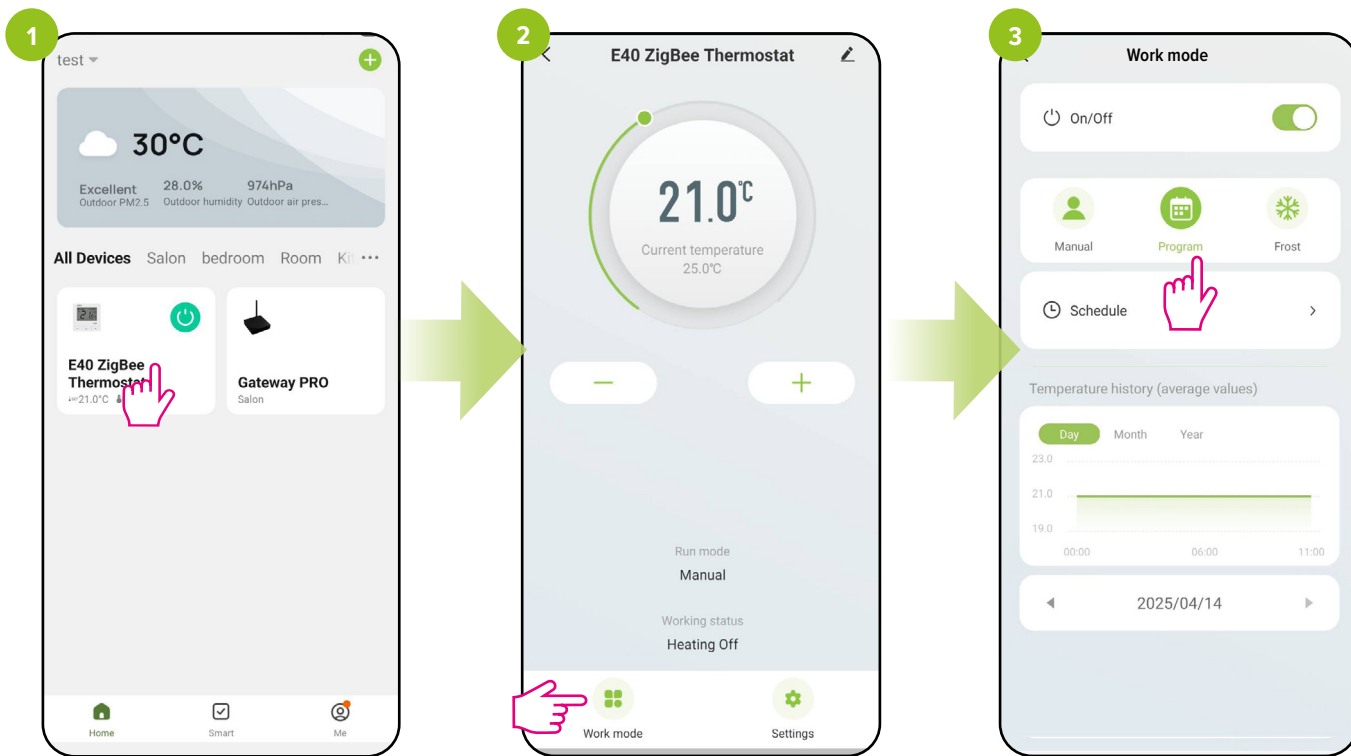

Enter the thermostat interface.

Select the „Work mode” option.

Select a schedule mode.

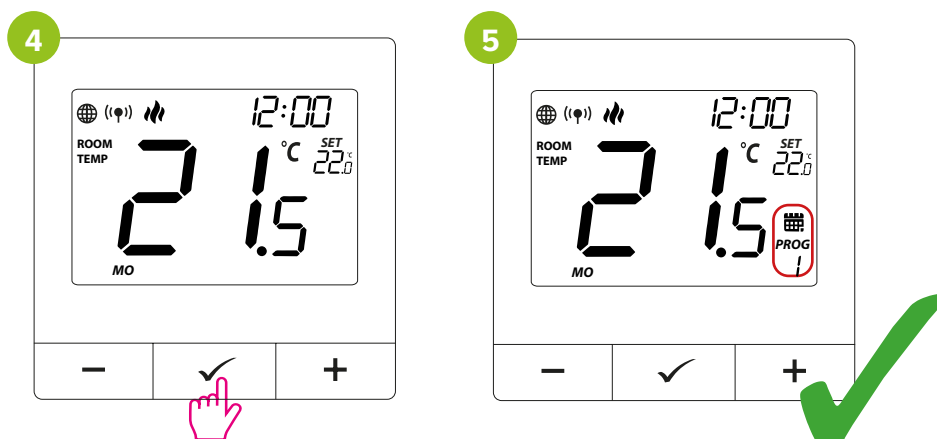

To change from manual mode to active schedule mode, click the button.
The schedule icon will appear on the thermostat screen.

TO PROGRAMME THE SCHEDULE IN THE APPLICATION:

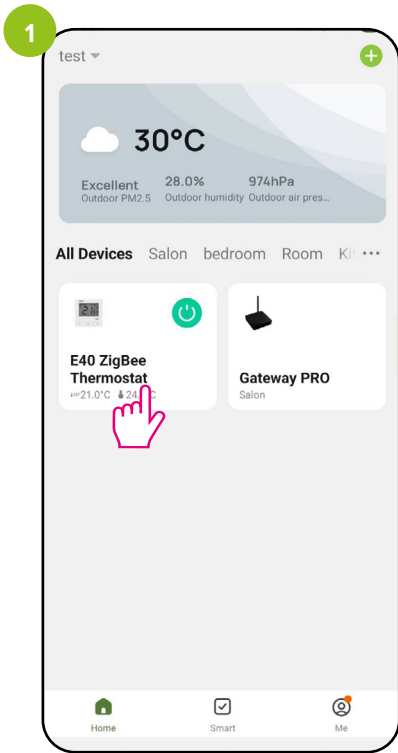

Enter the thermostat interface.

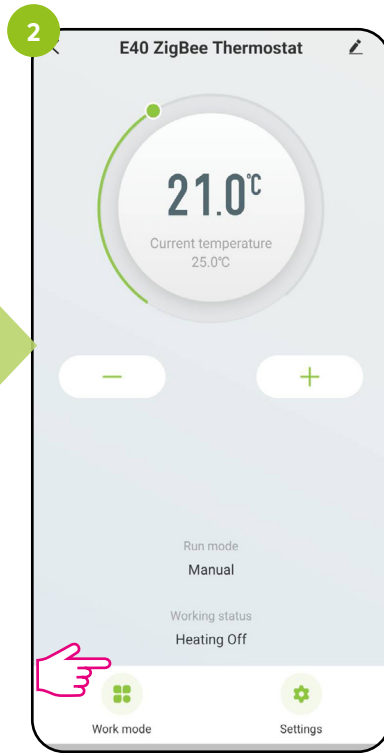

Select the „Work mode” option.

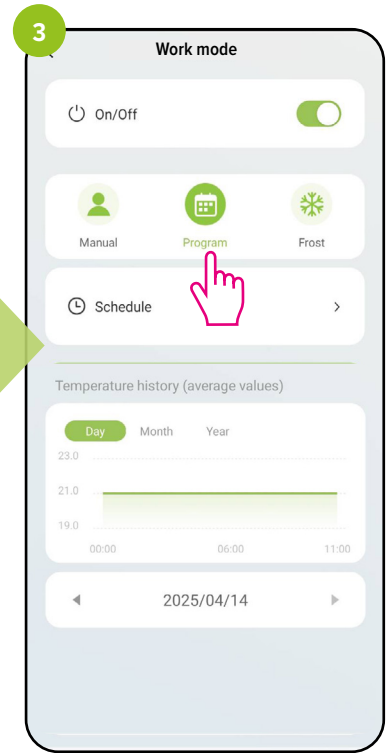

Select a schedule mode.

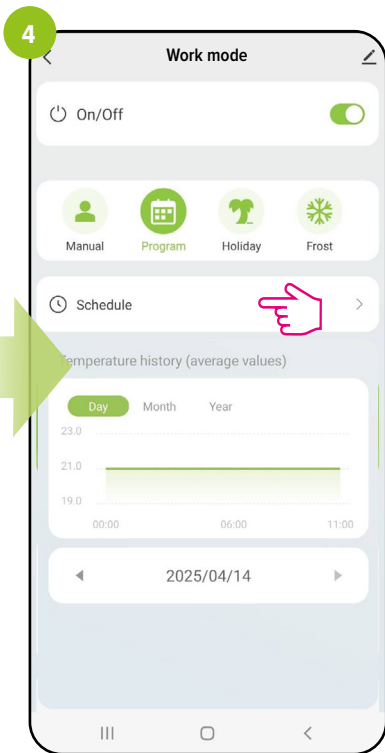

Enter the schedule settings.

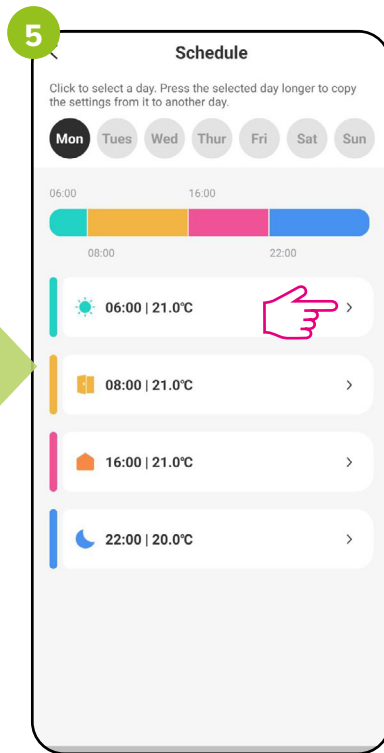

Select one of the four switch points to edit (the editing order is optional).

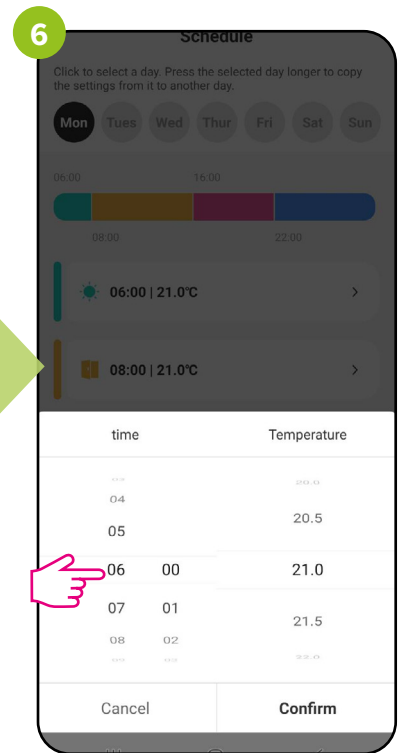

Select the start time of the switch point.

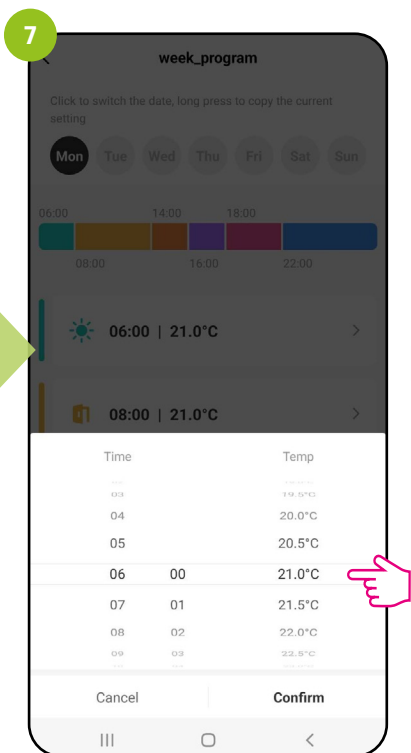

Set the temperature which applies when the program starts.

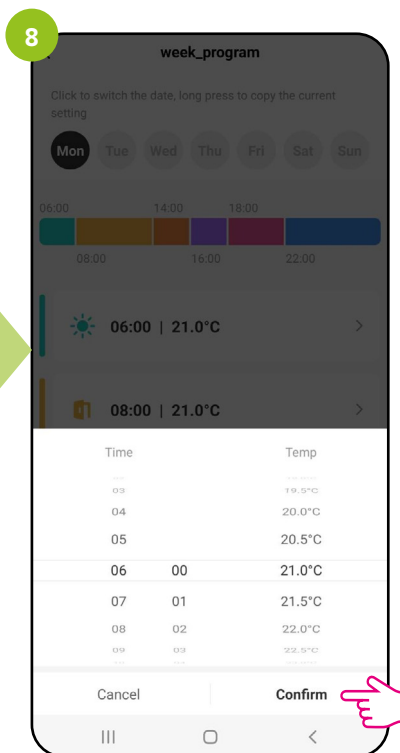

Next click „Confirm”.

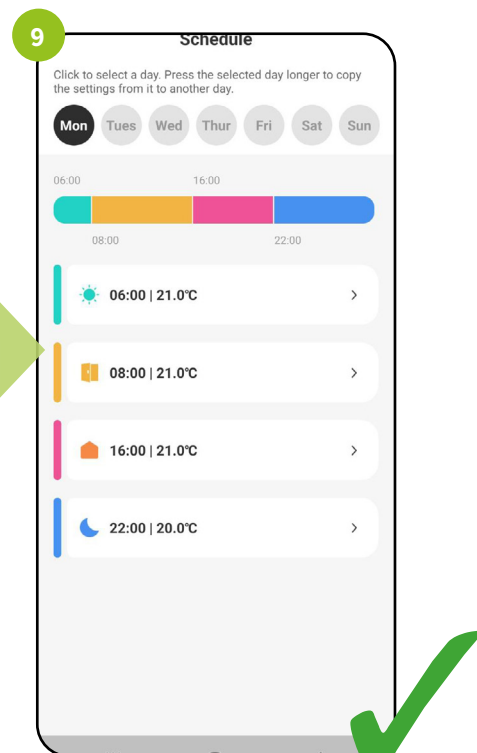

After all, you will see ready program in the schedule. Select another program and follow steps 5 to 8.

COPYING DAYS

The ENGO Smart app allows you to copy the settings of a selected day in the schedule to another. Thanks to this, you do not have to set the next day for the second time if you want to have exactly the same settings in it. To do so, please follow the steps below:

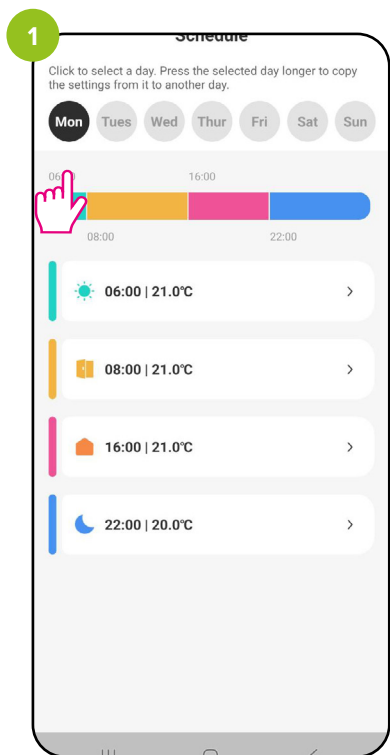

Select, press and hold the day you want to copy and transfer its settings to another.

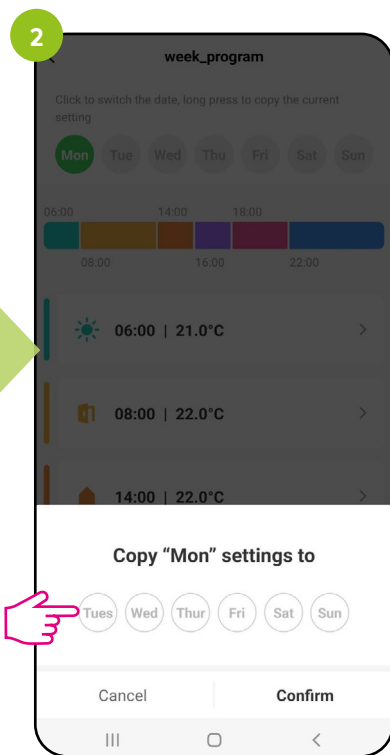

Then select the days for which you want to duplicate the settings.

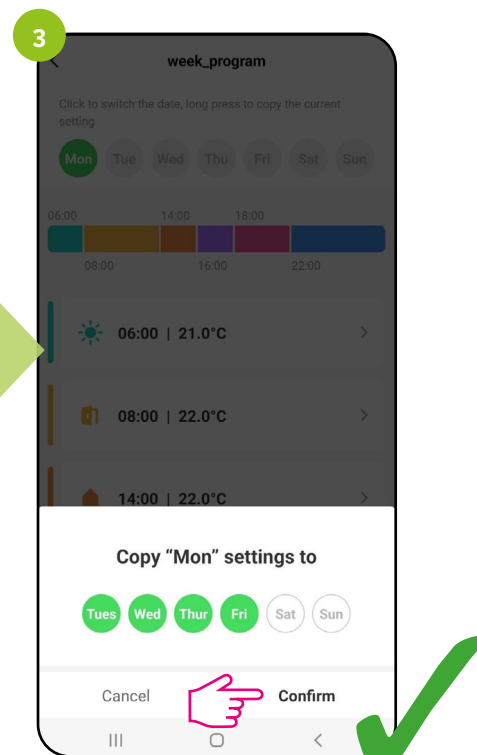

After selecting the days, confirm.

20.5 Temporary schedule overwrite mode

Temporary temperature override mode is activated when the user changes the temperature while the schedule is active. A hand and calendar icon on the thermostat and information about the temporary mode in the app then appears.

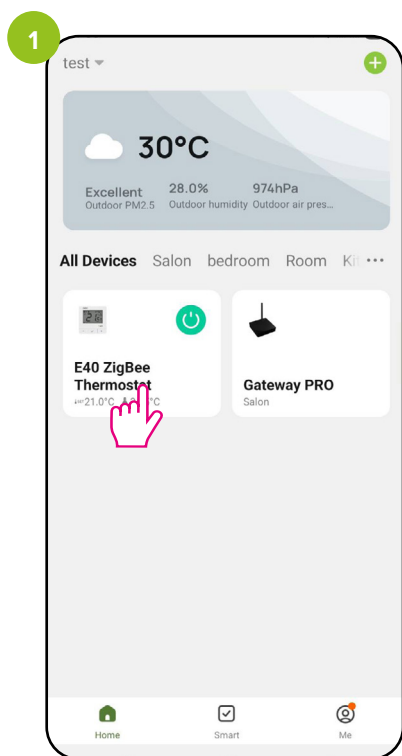

Enter the thermostat interface.

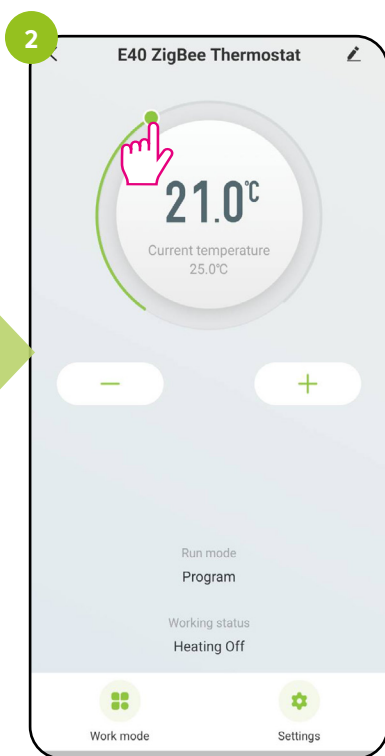

Change the desired temperature

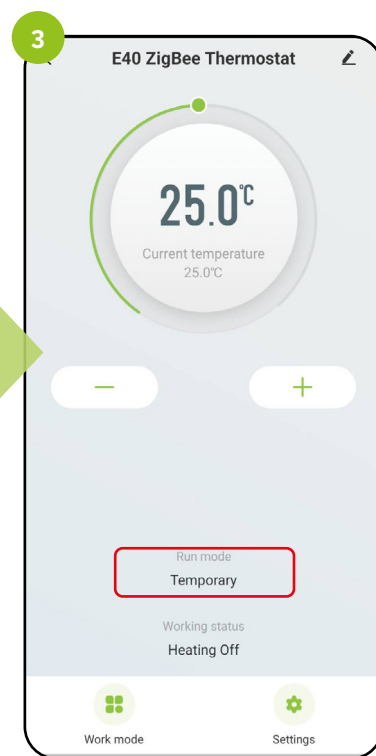

When the schedule is overwritten the operating mode changes from schedule to temporary mode.

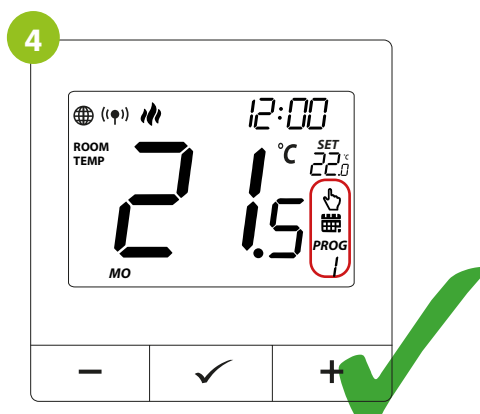

A calendar icon with a hand will appear on the thermostat.

Attention:

The overridden temperature will be maintained until the next schedule change occurs. At that point, the  icon will disappear from the display, and the controller will return to AUTO mode.

20.6 Frost mode

In FROST mode, the temperature setting range on the thermostat is 5°C to 17°C. When the anti-freeze (FROST) mode is active, a snowflake icon will be displayed on the thermostat in addition to the heating icon. When the ambient temperature falls below the set temperature in FROST mode, the thermostat will start sending a heating signal. This moment will be signalled by the application with a status change to „Heating on - FROST mode” and the heating icon will start animating on the thermostat. To exit FROST mode, select another operating mode.

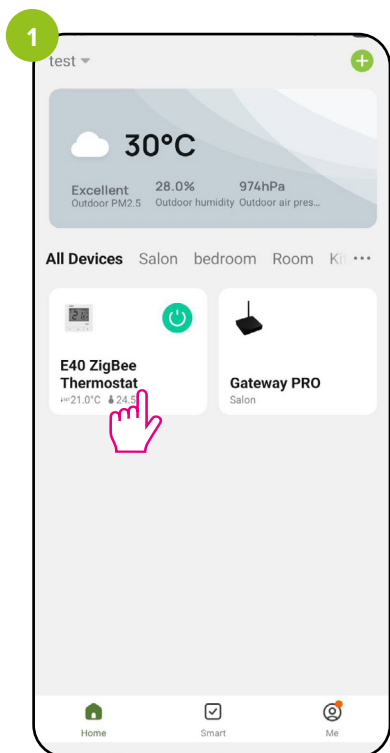

Enter the thermostat interface.

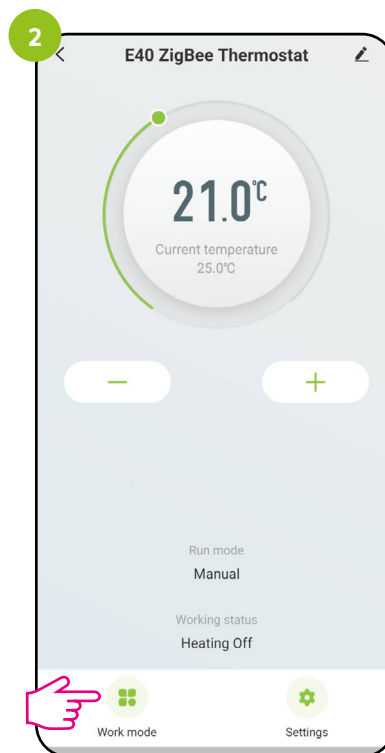

Select the „Work mode” option.

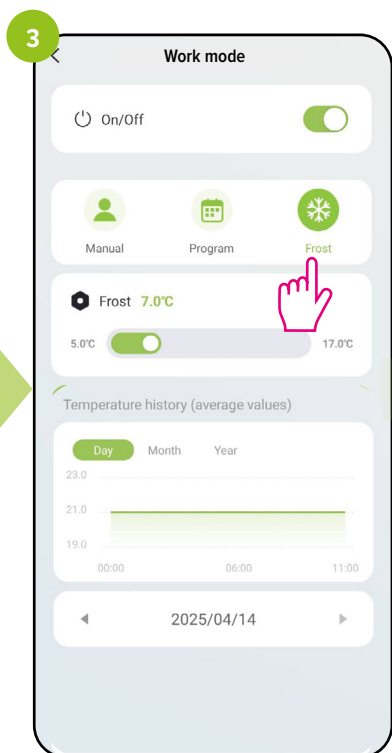

Select FROST mode.

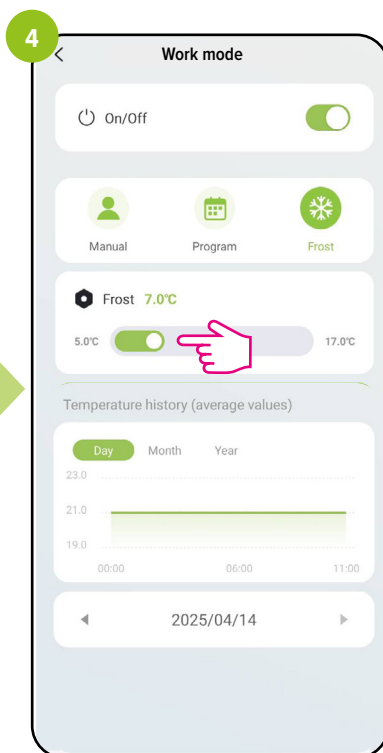

In FROST mode, the temperature setting range on the thermostat is 5°C to 17°C.

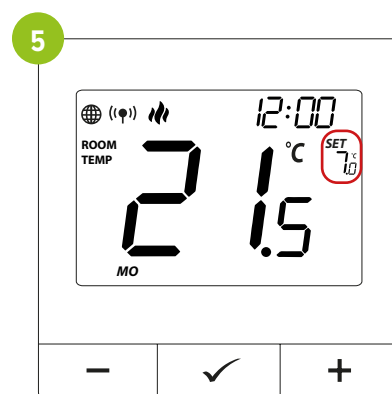

When FROST mode is active, a snowflake will appear on the thermostat screen in addition to the heating icon.

20.7 Diagrams

Room temperature history graphs for a selected day are available in the ENGO Smart app. These allow you to better plan the operation of the thermostat e.g. using a schedule mode based on the recorded data, which will make the operation even more economical.

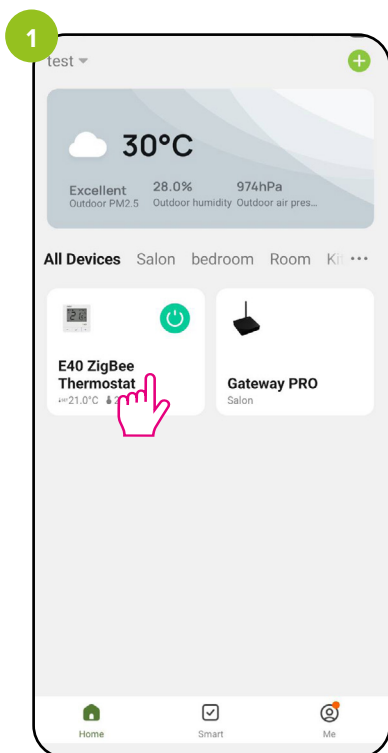

Enter the thermostat interface.

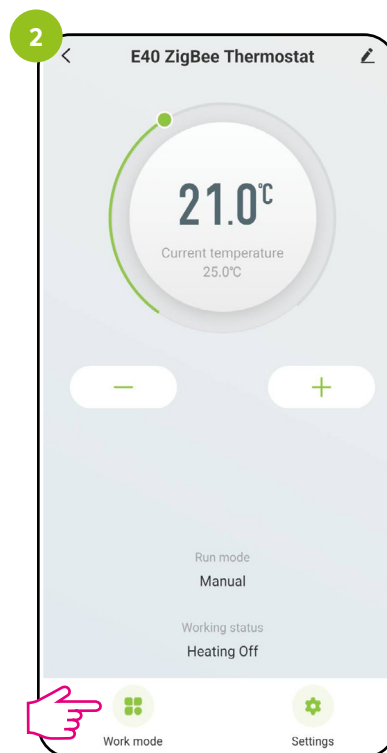

Select the „Work mode” option.

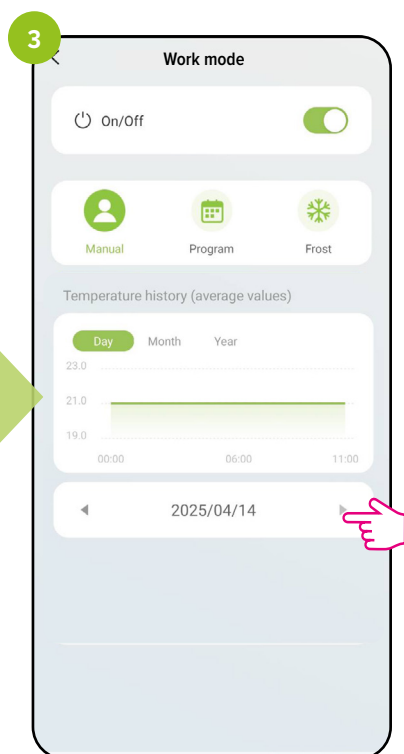

Click on the selected bar in the graph to display the history of the room temperature room temperature at a given hour of the selected day.

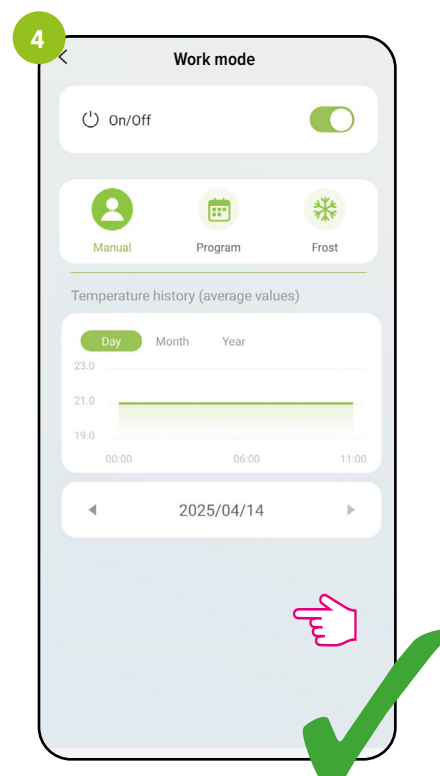

Choose the day that interests you.

21. Settings in the application (installer parameters)

21.1 Key lock function

The app allows you to lock the buttons on your device. Simply change the position of the slider on the screen. When the slider is highlighted in green and is on the right, the thermostat keys are locked. To unlock, press the slider so that it is unlit and on the left. Then the keys on the thermostat are unlocked. You can also lock/unlock from the thermostat using the UP and OK keys.

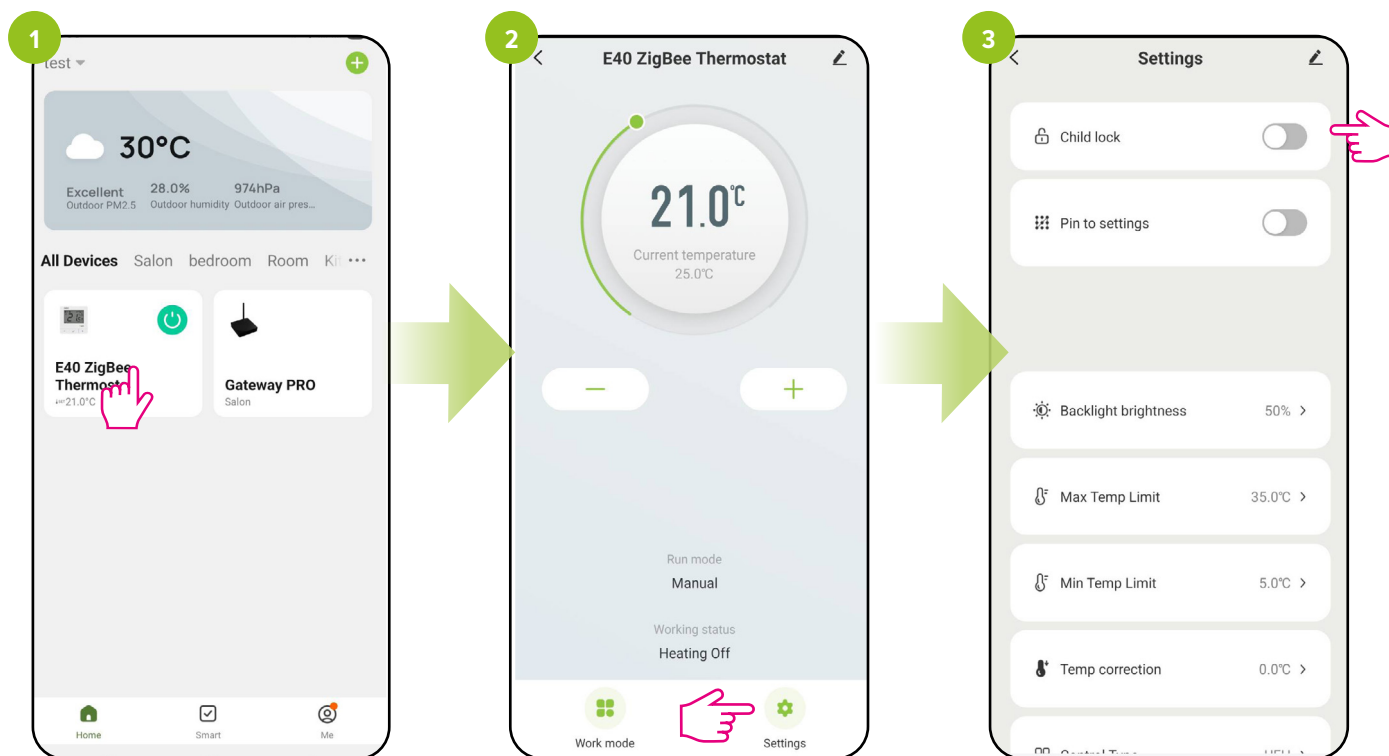

Enter the thermostat interface.

Select the „Settings” option.

Use the slider to lock / unlock the keys on the thermostat.

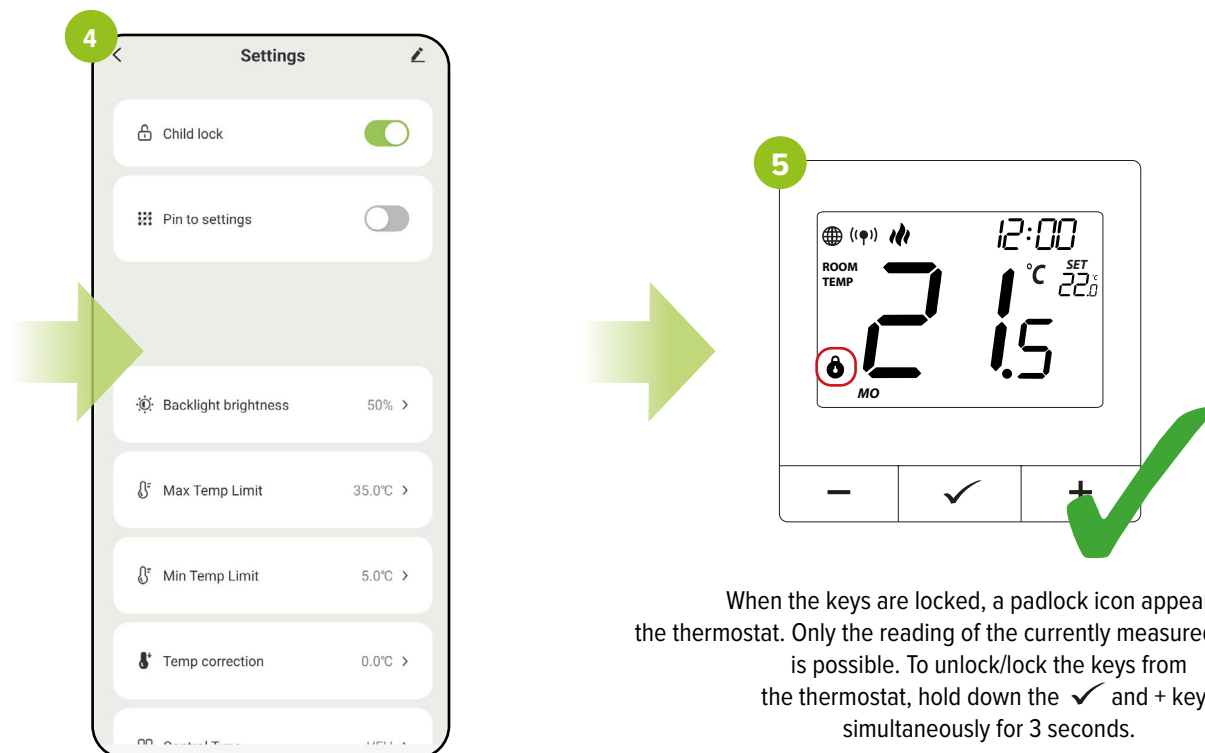

When the slider is highlighted in green, the thermostat keys are locked.

When the keys are locked, a padlock icon appears on the thermostat. Only the reading of the currently measured temperature is possible. To unlock/lock the keys from the thermostat, hold down the ✓ and + keys simultaneously for 3 seconds.

21.2 Setting PIN

From the app, the user has the option to enable or disable PIN locking for installer settings and to unlock the keypad.

 **ATTENTION!!!** There is the possibility of additional PIN code locks on the thermostat. This is done using parameters P08 and P09. In the installer settings:

1. After activating parameter P07 and setting a new PIN code in parameter P08, the user will have to enter the PIN code each time to enter the installer parameter settings.

2. An additional function is to lock the keys also on the PIN code. To activate this function, first set the PIN code in parameter P08 in the installer settings and then activate parameter P09. Once P09 is activated, the PIN code is required each time the keys are unlocked.

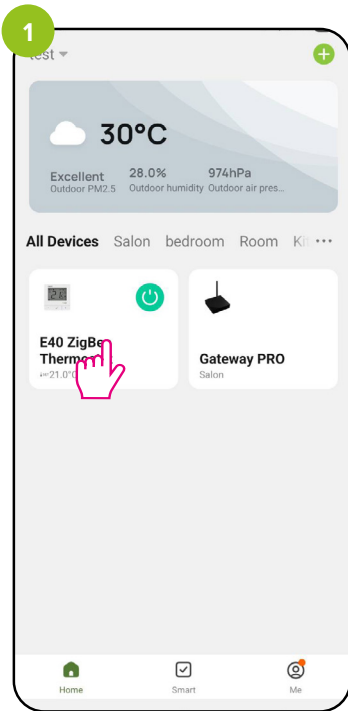

Enter the thermostat interface.

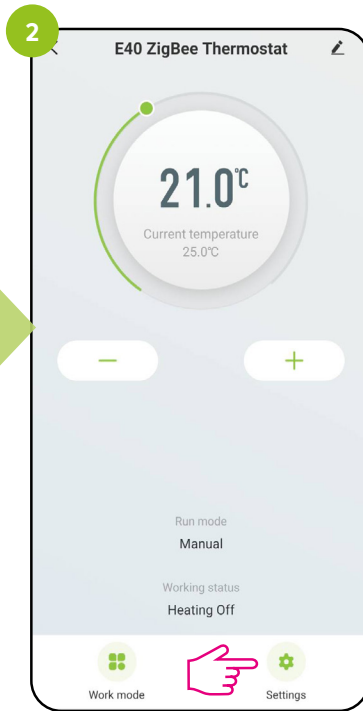

Select the „Settings” option.

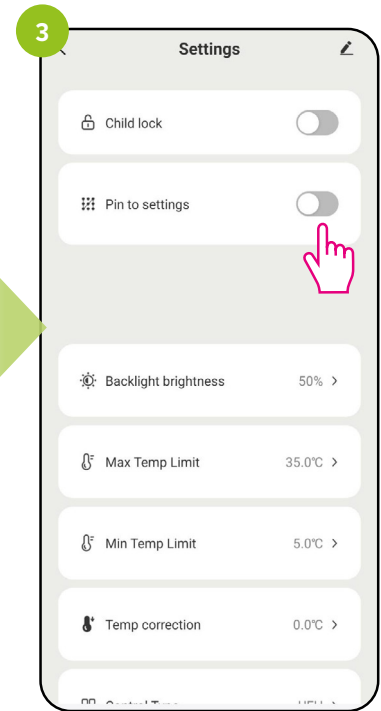

If the PIN for settings is enabled, the user of the thermostat will each time will have to enter the PIN code in order to enter the installer settings.

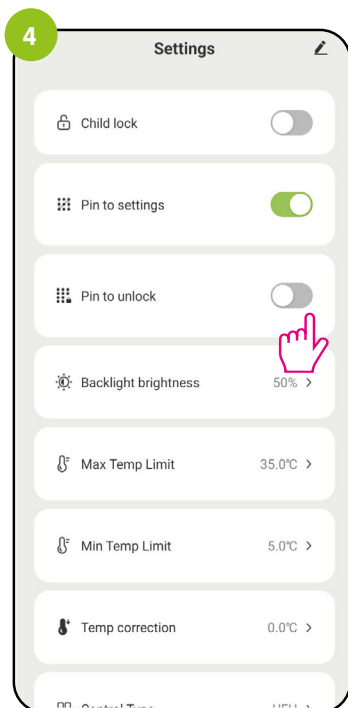

If the PIN for settings is enabled, a new parameter - PIN for unlocking (keys on the thermostat).

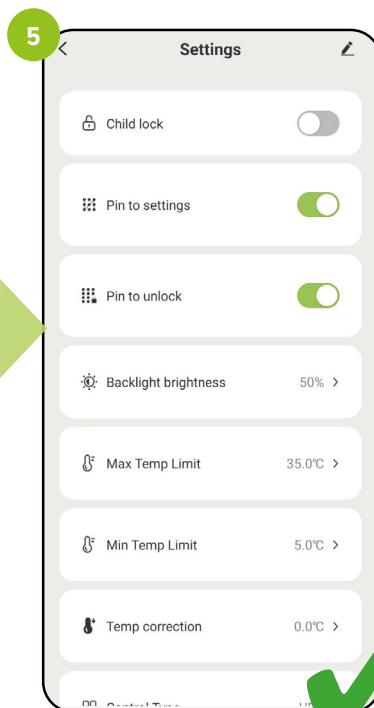

If the unlock PIN is enabled, then the user will each time PIN code will have to be entered in order to unlock thermostat keys.

21.3 Display brightness

The user can change the brightness of the thermostat display. Move the slider in the appropriate direction, as in the steps shown below:

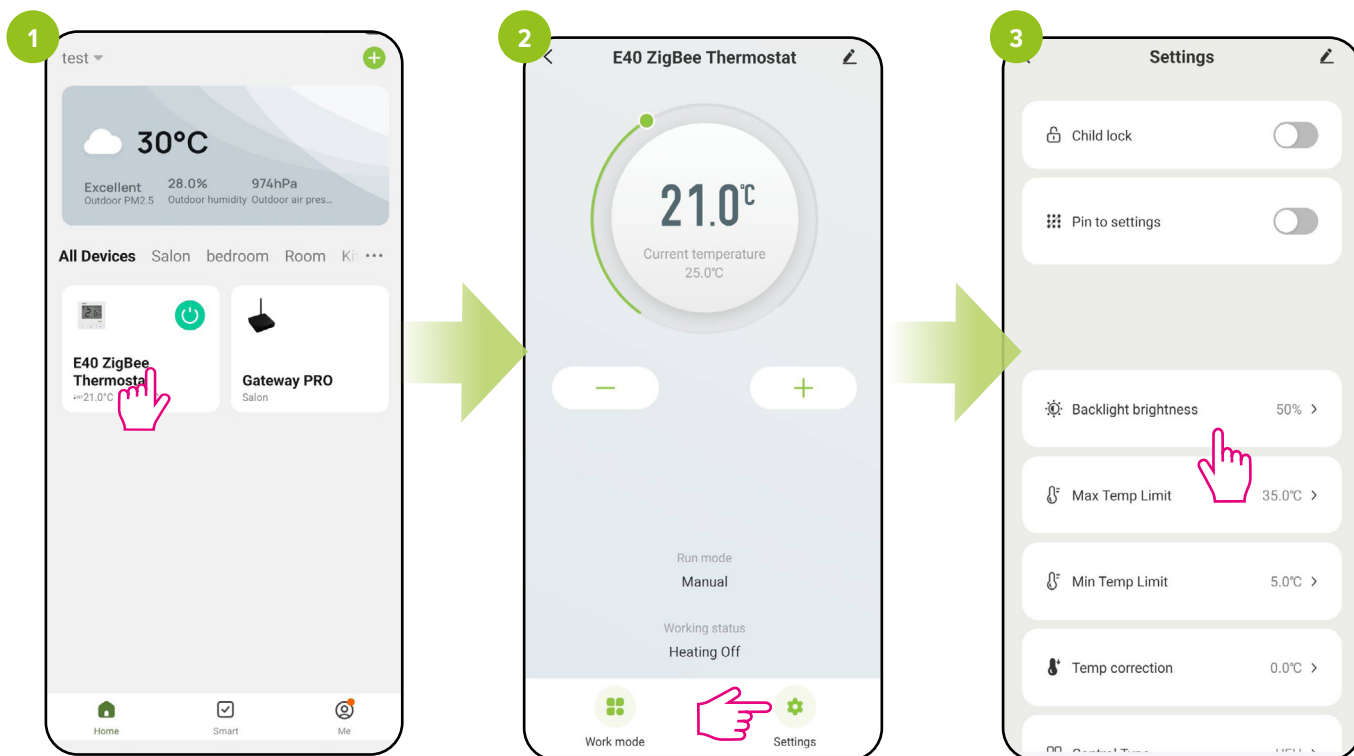

Enter the thermostat interface.

Select the „Settings” option.

Select „Backlight brightness”.

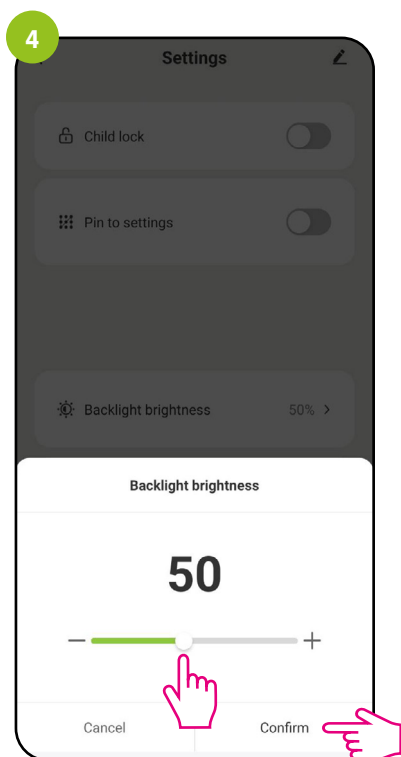

Move the slider to set the brightness of the display. Then click „Confirm”.

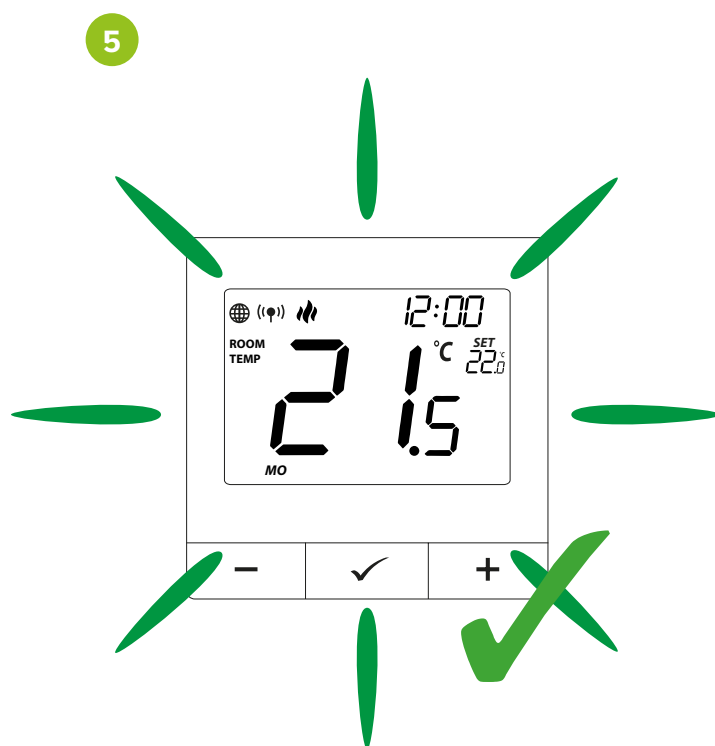

When the slider is moved (see previous step) the regulator display automatically changes its brightness.

21.4 Maximum temp. limit

This parameter allows you to set the maximum set temperature on the thermostat. Look at the steps below:

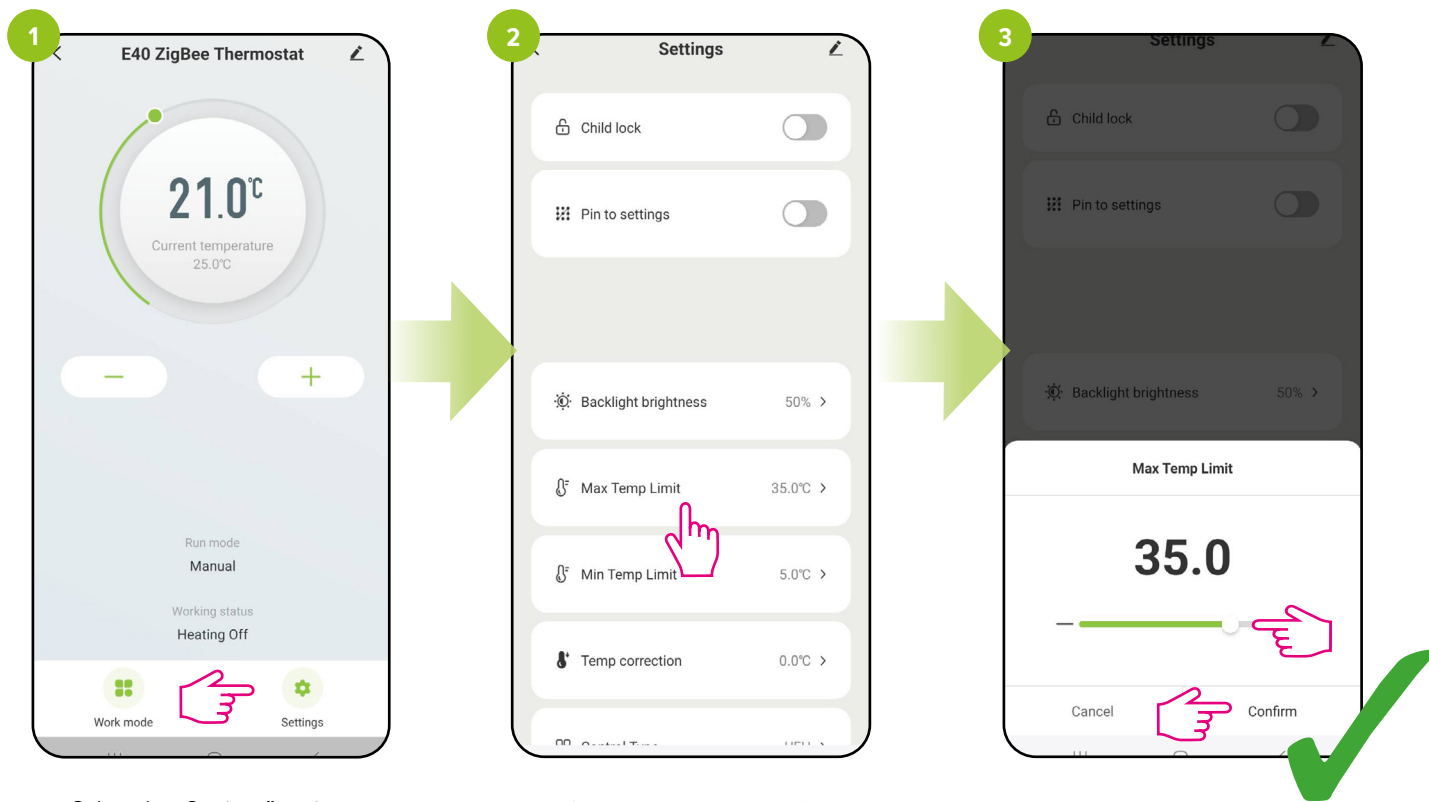

Select the „Settings” option.

Select „Max Temp Limit”.

Move the slider to change the value for the maximum setpoint temperature (from 5°C to 45°C). Then click „Confirm”.

21.5 Minimum temp. limit

This parameter allows you to set the minimum set temperature on the thermostat. Look at the steps below:

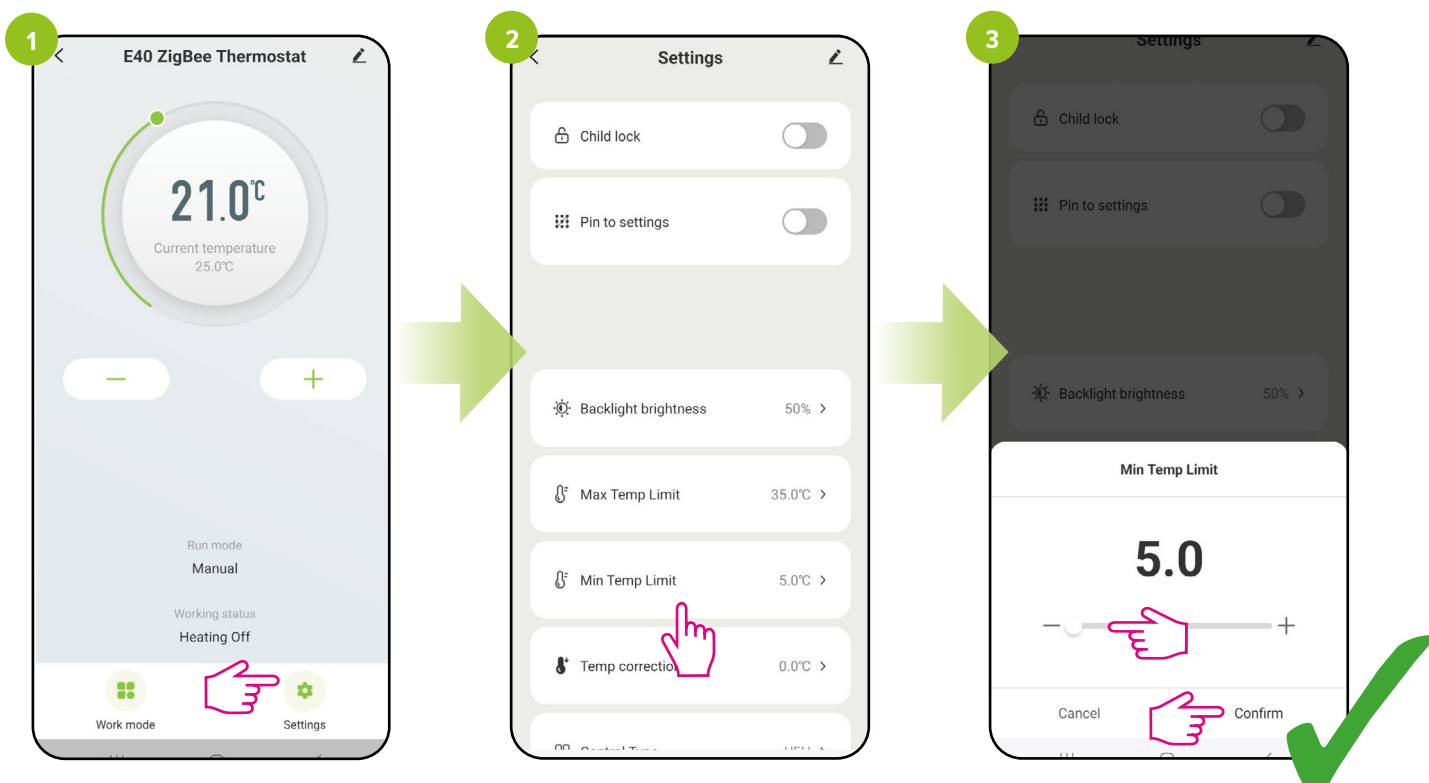

Select the „Settings” option.

Select „Min Temp Limit”.

Move the slider to change the value for the minimum temperature setpoint (from 5°C to 45°C). Then click „Confirm”.

21.6 Temperature correction

This function allows you to correct the displayed room temperature by $\pm 3.5^{\circ}\text{C}$ in steps of 0.5°C . Look at the steps below:

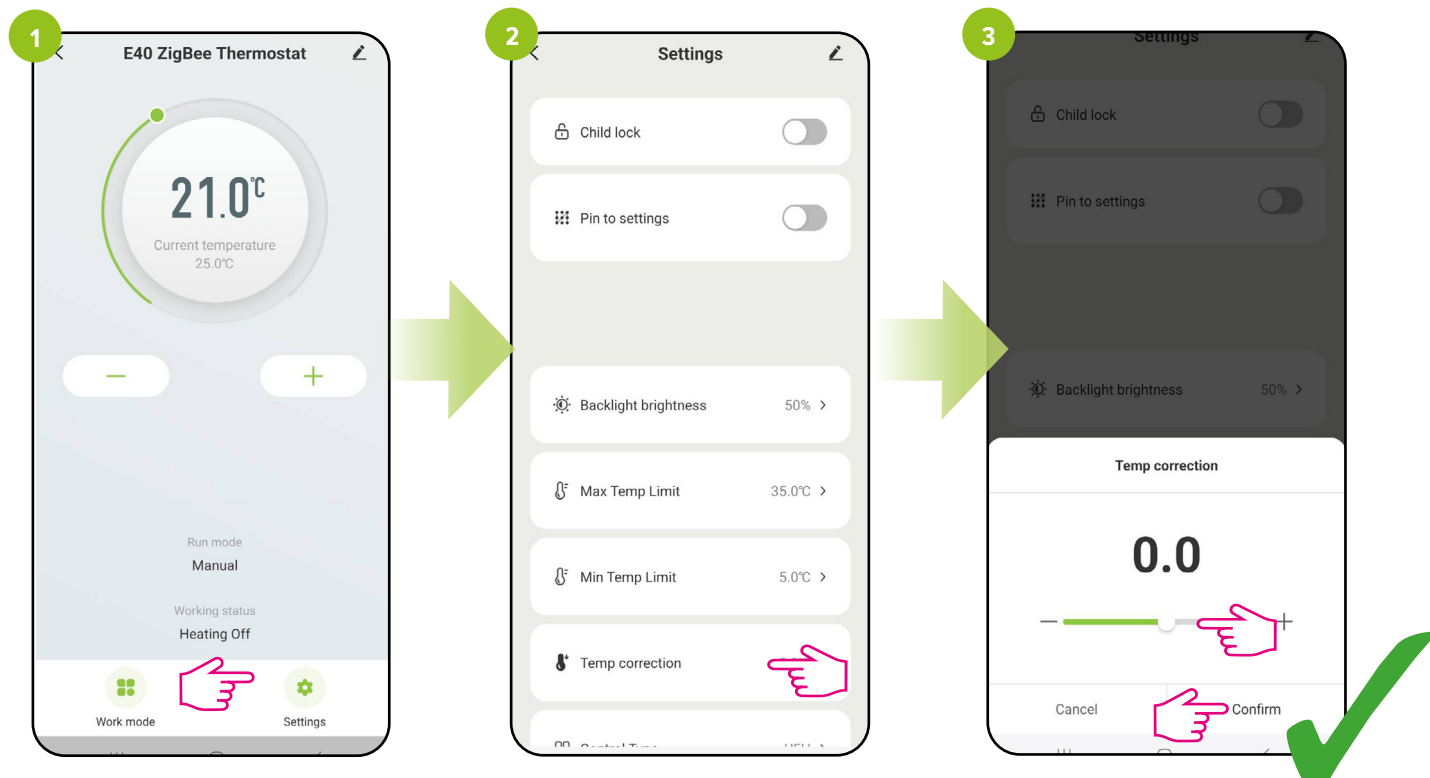

Select the „Settings” option.

Select „Temp correction”.

Move the slider to select the value by how much you want to make an adjustment for the current temperature. Then click „Confirm”.

21.7 Control algorithm

The hysteresis is the temperature difference between switching the heating unit on and off. If an ON/OFF (hysteresis) thermostat is used in a slow-response system (e.g. underfloor heating), underheating and overheating cycles cannot be avoided. It is difficult to maintain a constant room temperature because the thermostat starts up when the temperature falls below the set point. With a system with high thermal inertia, the room temperature can continue to fall after the thermostat is switched on. Also conversely, the thermostat switches off when the temperature is higher than the setpoint. After the thermostat is switched off, the room temperature continues to rise because the heated concrete floor has to give up heat to the surroundings. The hysteresis value can be changed from $\pm 0.1^{\circ}\text{C}$ to $\pm 2.0^{\circ}\text{C}$ - the lower the value, the quicker the thermostat will react to a change in room temperature. For example, if you set the temperature to 20°C and if the hysteresis is 0.5°C , heating will be switched on when the temperature drops to 19.5°C and off when the temperature reaches 20.5°C .

The TPI algorithm works differently compared to the hysteresis. room temperature closest to the setpoint It selects „time pulses of a few or several minutes” to switch the heating unit on and off in such a way as to maintain the values. Even when the temperature has been reached, it still reheats with pulses to maintain comfort in the room. TPI (Time Proportional and Integral) is an algorithm that has a simple memory in its software by which it „learns” how temperatures are reached and maintained in the room. It has a basic computational capability: „works” with the collected data and current temperatures, „predicting” how long the heat must be supplied (the heating must be on). It is a kind of ‚intelligent control’ in that the heat delivery takes as long as it takes to reach the set point and shuts down, increasing energy efficiency. The TPI works according to cycles, the length of which is measured in quantities per hour. During normal use, you will notice that the thermostat runs for a shorter period as it approaches the set temperature. When the set point is reached, the periods of operation become short in order to maintain the temperature. On the E40 thermostat, the TPI algorithm can be selected for a specific type of heating (underfloor, radiator or electric).

How to set the control algorithm in the ENGO Smart application for the E40 thermostat:

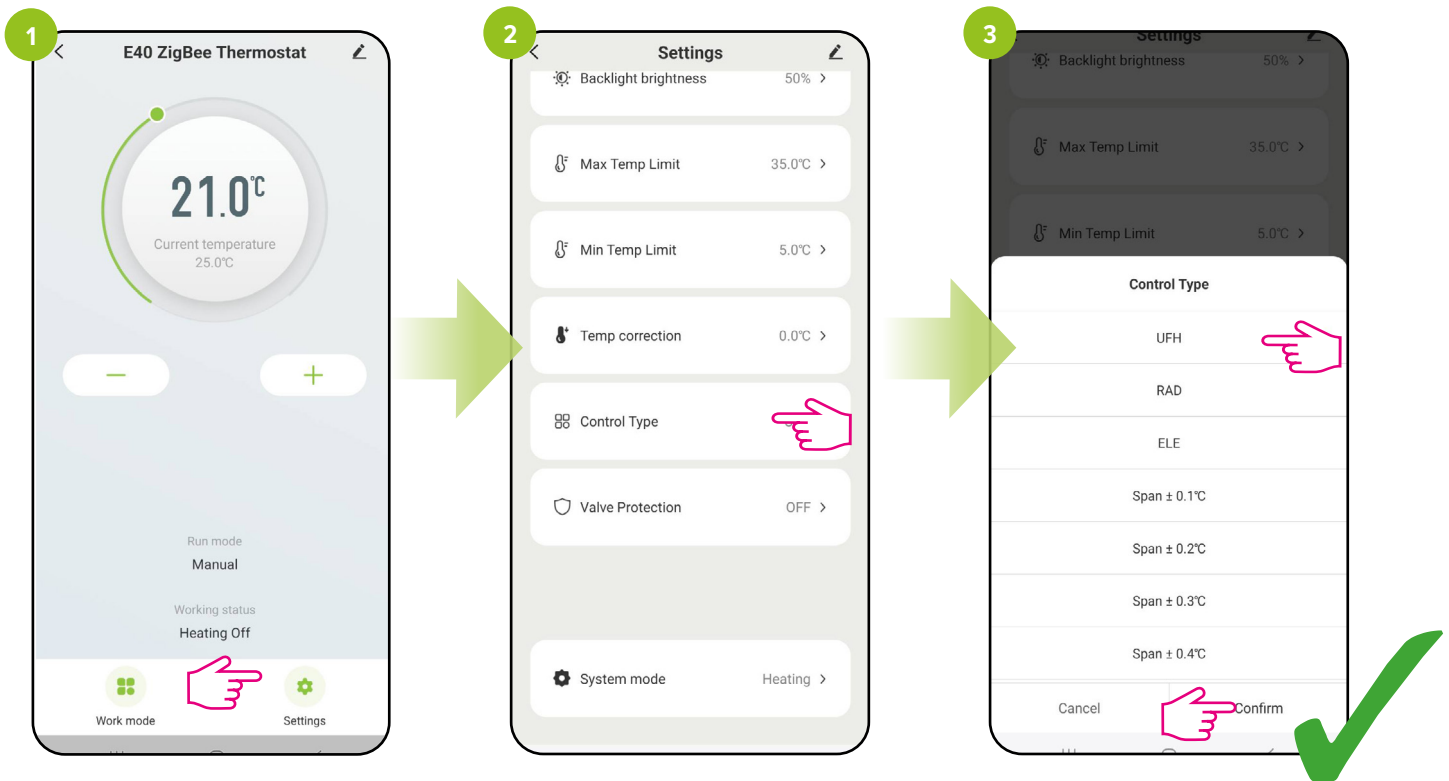

Select the „Settings” option.

Click on „Control Type”.

Select the algorithm with which you want to regulate the room temperature. Then click „Confirm”.

NOTES:

If the thermostat is synchronised with an ETRV electronic radiator head, the parameter is not available.

21.8 Relay type

E40-230 thermostat has a built-in relay that allows wired control of, for example, a gas boiler, circulating pump, or cooperation with a wired control box.

Modes of relay operation:

NO-COM – Normal Open type of relay (factory setting)

NC-COM – Normal Close type of relay (logic of operation reversed by software)

OFF – Built-in relay disabled

Follow the steps below to change the way the relay works:

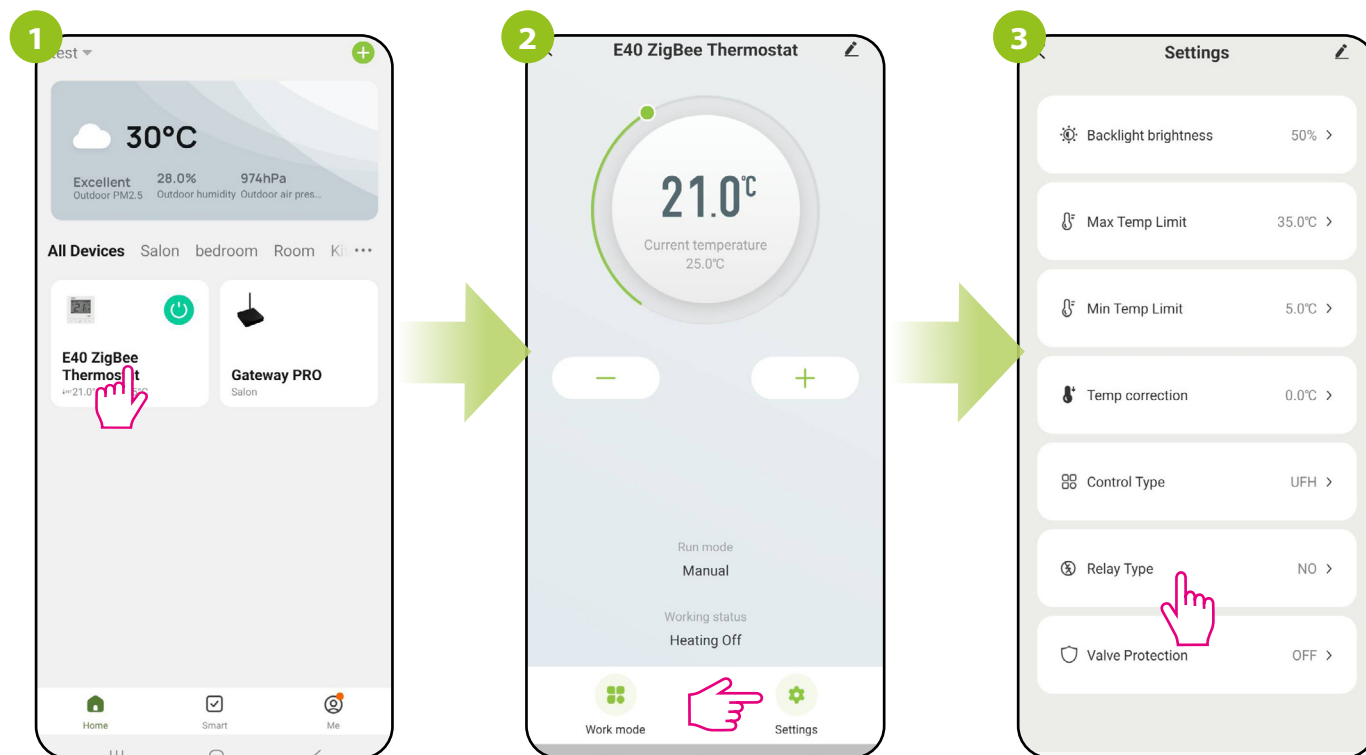

Enter the thermostat interface.

Select the „Settings” option.

Click on „Relay Type”.

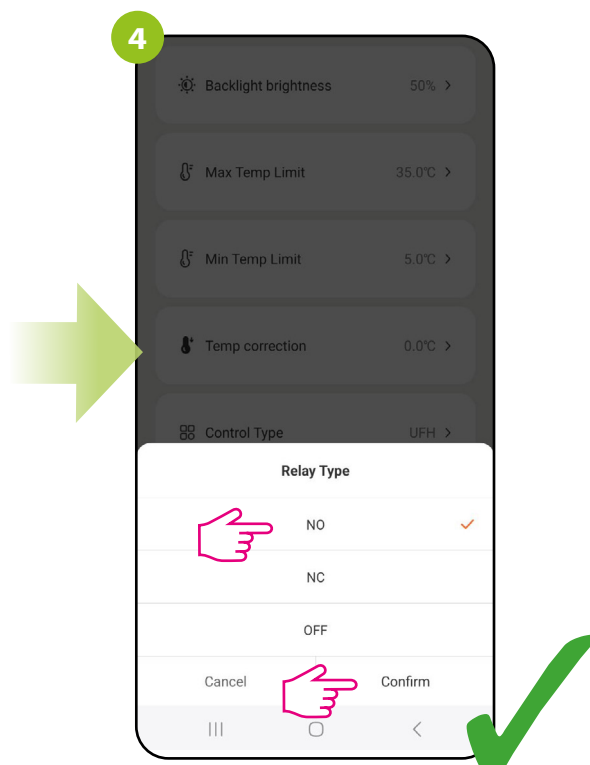

Select the relay type.
Then click "Confirm".

21.9 VP valve protection and ANTISTOP function

The valve protection function is designed to protect the thermostatic valves from stagnation or jamming (e.g. in summer when the heating is off). If the thermostat does not send the heating signal for a period of 7 days, heating is switched on for a very short period of time in order to start the thermoelectric actuators and move the thermostatic inserts (e.g. in an underfloor heating manifold).

In the antistop function, the heating activation time is a few minutes longer so that, in addition to the valve inserts, the circulation pump is activated. To activate the floor valve protection follow the following steps:

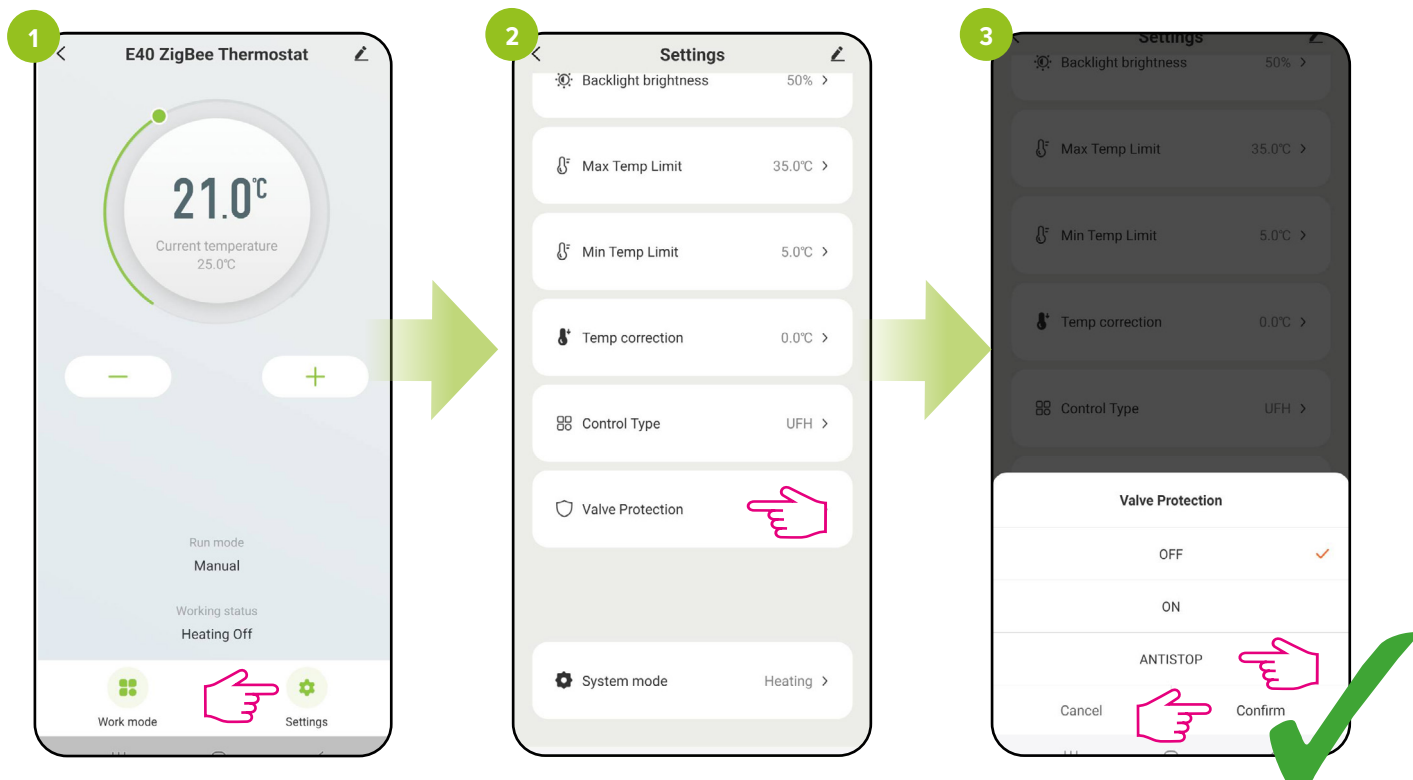

Select the „Settings” option.

Click „Valve protection”.

Switch valve protection or antistop on or off. Then click „Confirm”.

21.10 Settings for TRV radiator head

21.10.1 Changing the head name

Name the head by following the steps below:

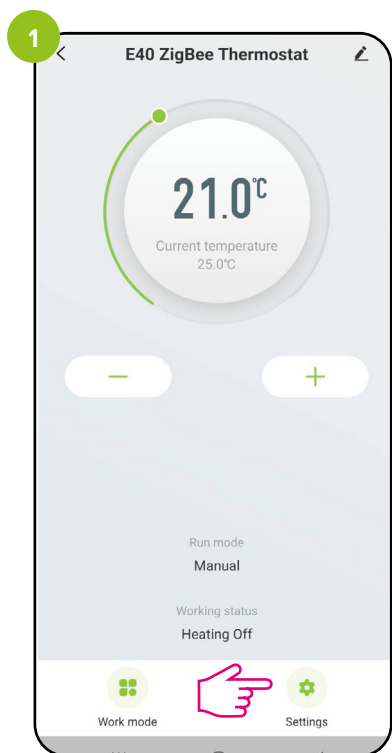

Select the „Settings” option.

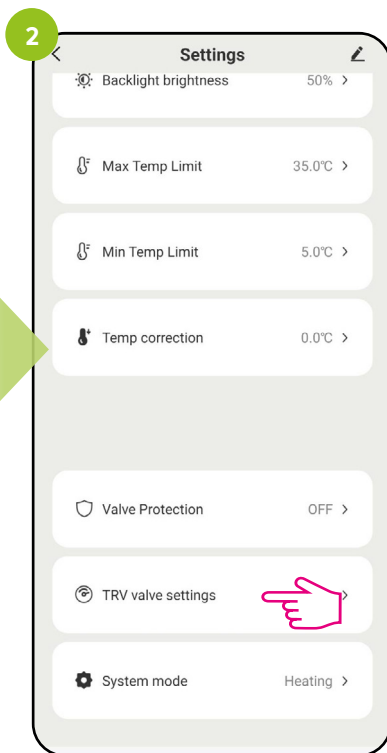

Click on „TRV valve settings”.



The name can only be changed when the head is synchronised with the thermostat.

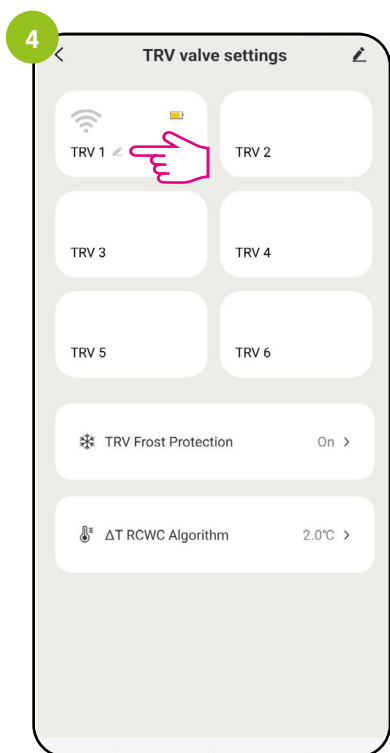

Click the pencil icon next to the selected head.

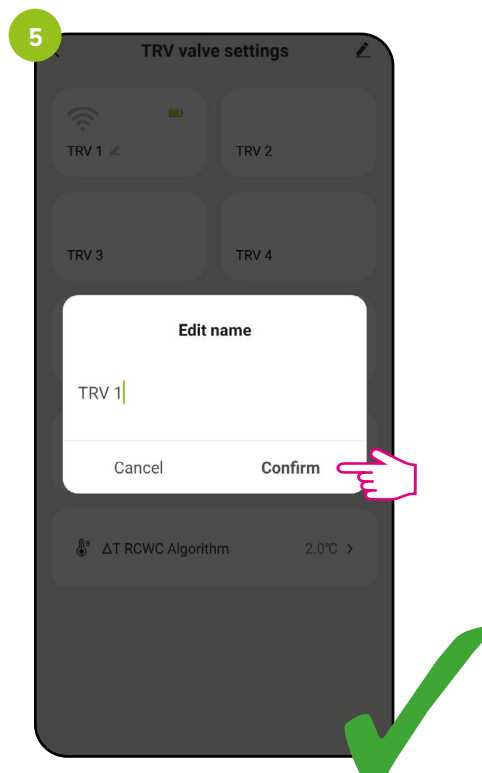

Rename the head.
Then click „Confirm”.

21.10.2 Triggering head update

Follow the steps below to update the ETRV head:

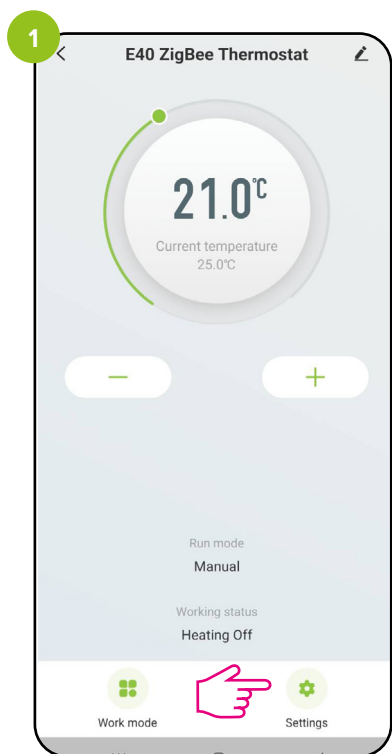

Select the „Settings” option.

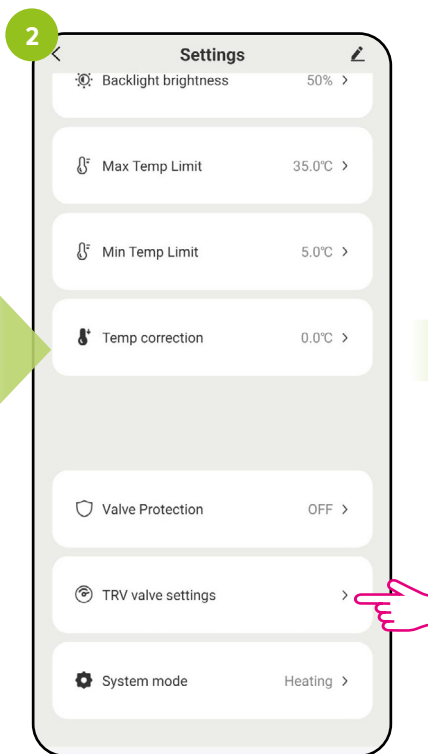

Go to „TRV valve settings”.

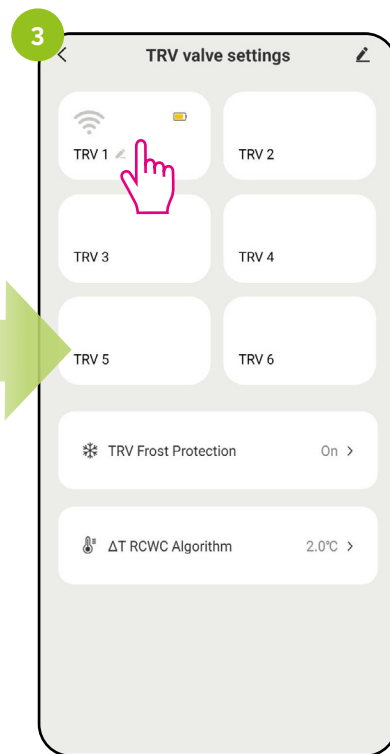

Select the head you wish to update.

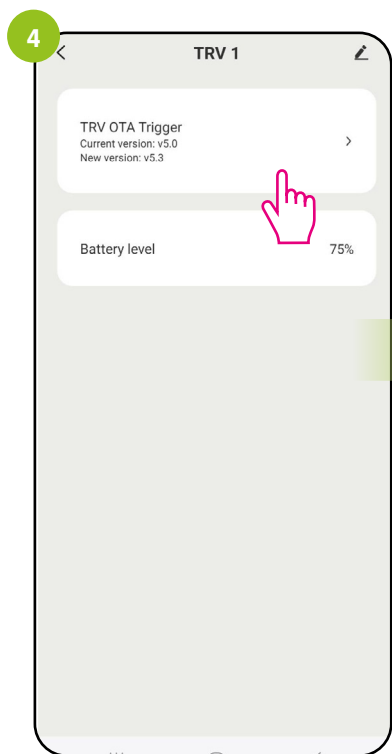

If a new software version is available, click to update the head.

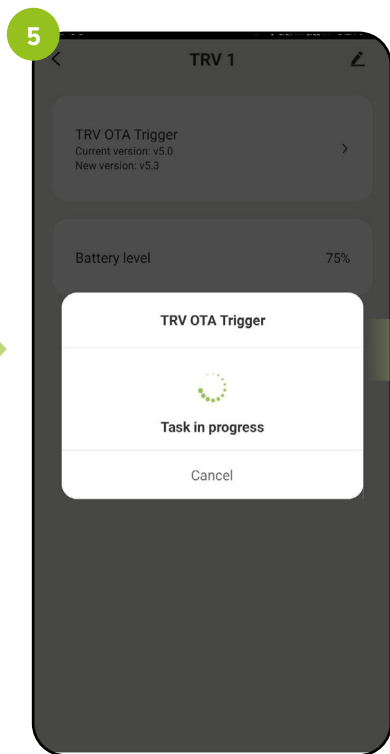

Wait for the head to update. During the update, the LED on the head flashes pink.

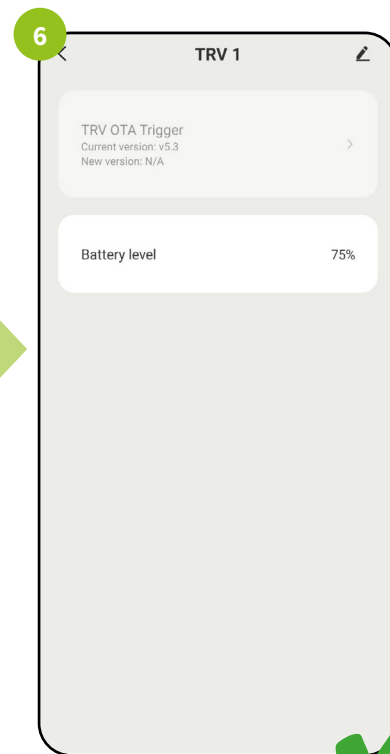

After the correct update, the soft in the head changed to a newer version.

21.10.3 Battery condition in the TRV head

Follow the steps below to check the status of the head battery:

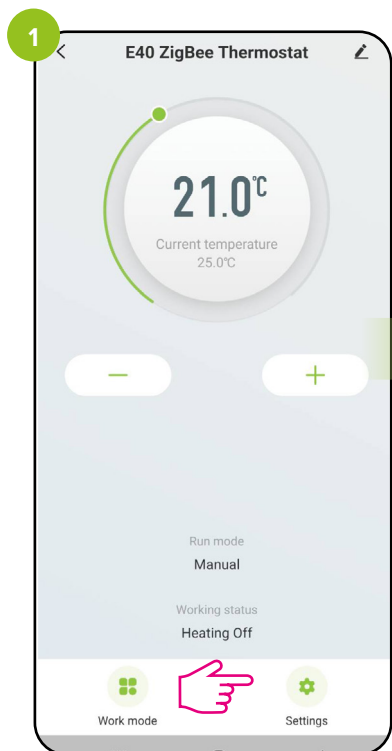

Select the „Settings” option.

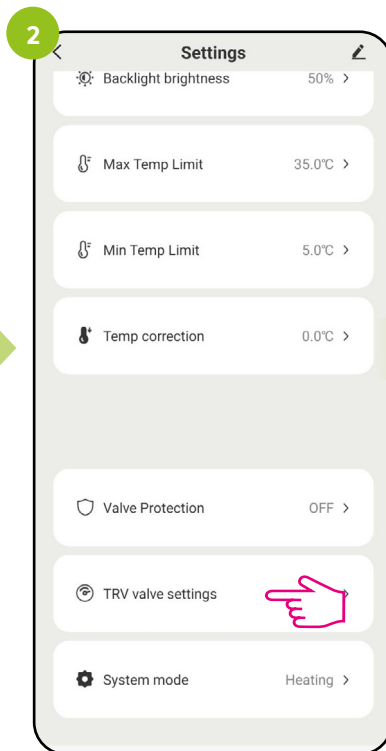

Go to „TRV valve settings”.

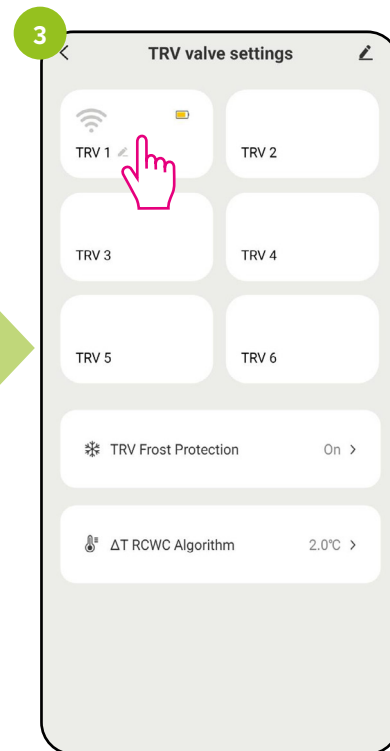

Select the head where you want to check the battery status.

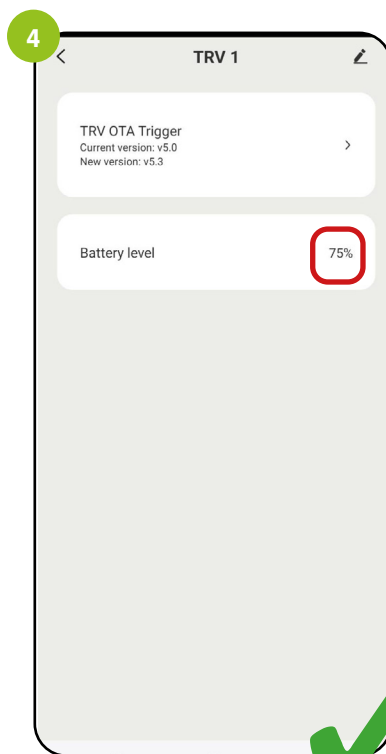

The battery status is visible in the app.

21.10.4 Protection against head freezing

When the ETRV valve is closed, frost protection is automatically activated. If the temperature sensor in the valve detects a temperature drop below 5°C, the valve opens to supply heat to the radiator and prevent freezing.

Follow the steps below to enable or disable TRV protection:

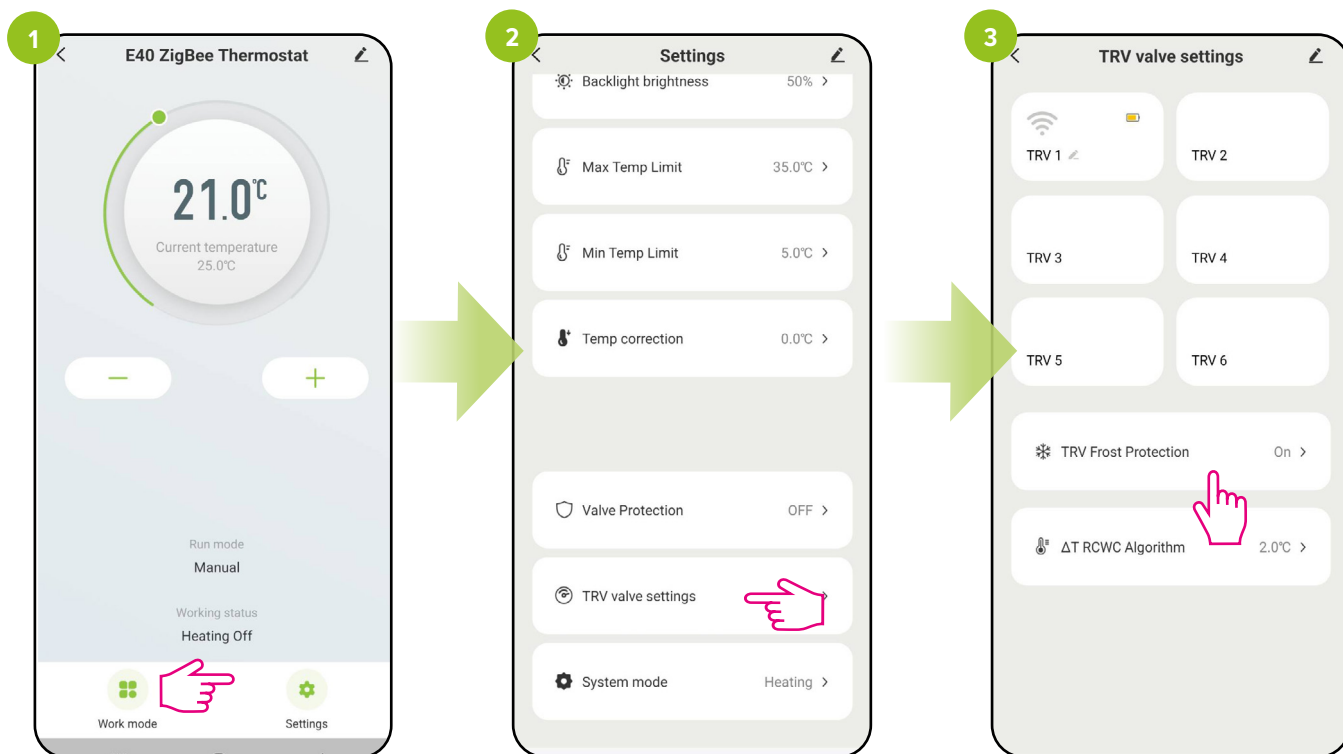

Select the „Settings” option.

Go to „TRV valve settings”.

Select „TRV Frost Protection”.

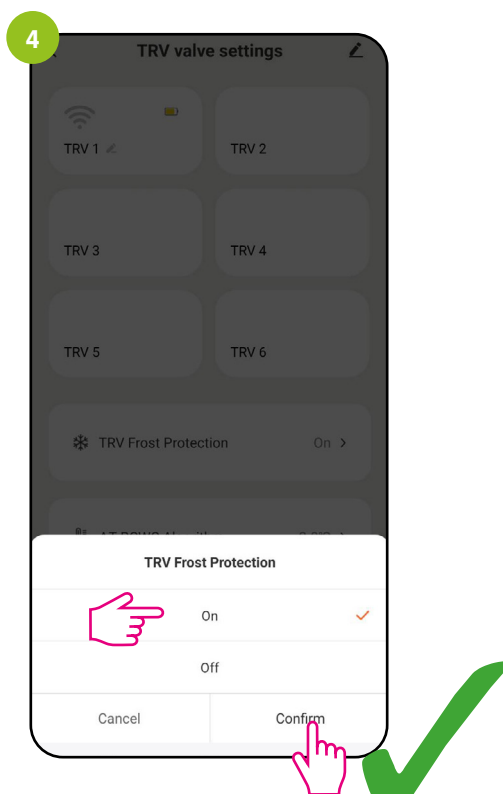

Enable or disable head protection.
Then click „Confirm”.

21.10.5 Control of TRV - ΔT RCWC algorithm

When the room temperature changes, the head opens in proportion to the size of the delta. The smaller the delta of the RCWC, the faster the response of the valve. For example, if the parameter value is 2 degrees, the valve opens to 100% when the temperature drops by 2 degrees. To change the level of the ΔT RCWC parameter, follow the steps below:

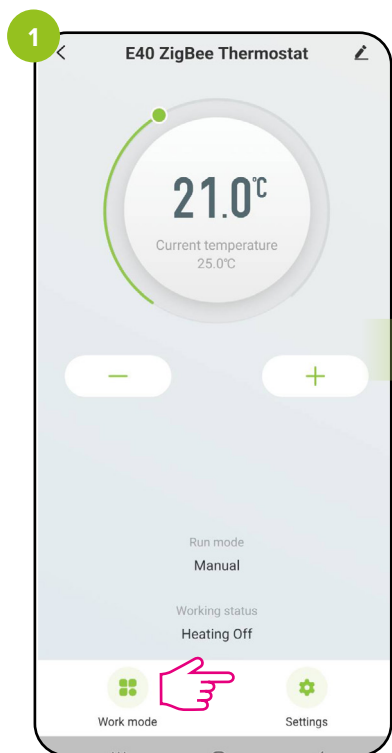

Select the „Settings” option.

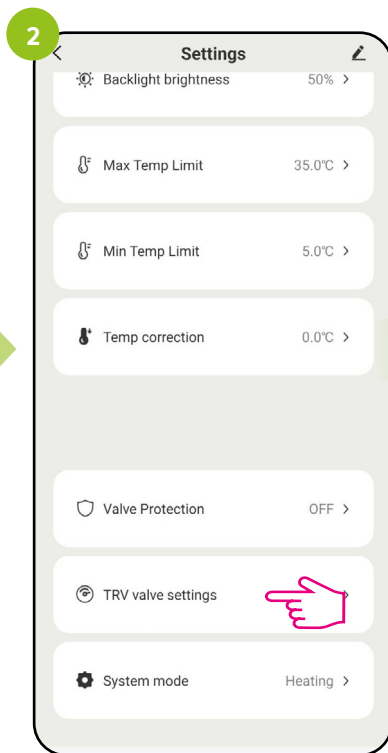

Go to „TRV valve settings”.

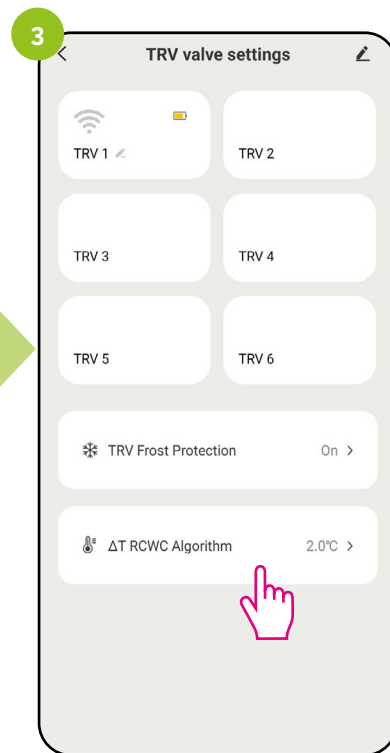

Select „ ΔT RCWC Algorithm”.

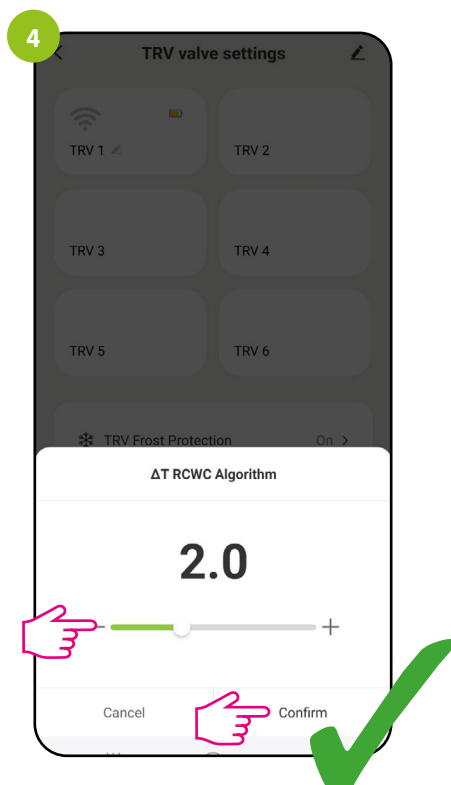

Set the desired level and click „Confirm”.

The $\Delta RCWC$ algorithm is responsible for controlling the wireless head. Based on the delta between the set temperature and the room temperature, the thermostat selects the head opening percentage and modulates its opening. Two-way communication between the devices takes place every few minutes by radio.

When the measured temperature is equal to the setpoint temperature - the head is closed.

For example, in heating mode, if the temperature drops, the valve will be opened in proportion to the size of the selected delta.

The parameter is set in the thermostat paired with the head. By default $\Delta RCWC = 2C$.

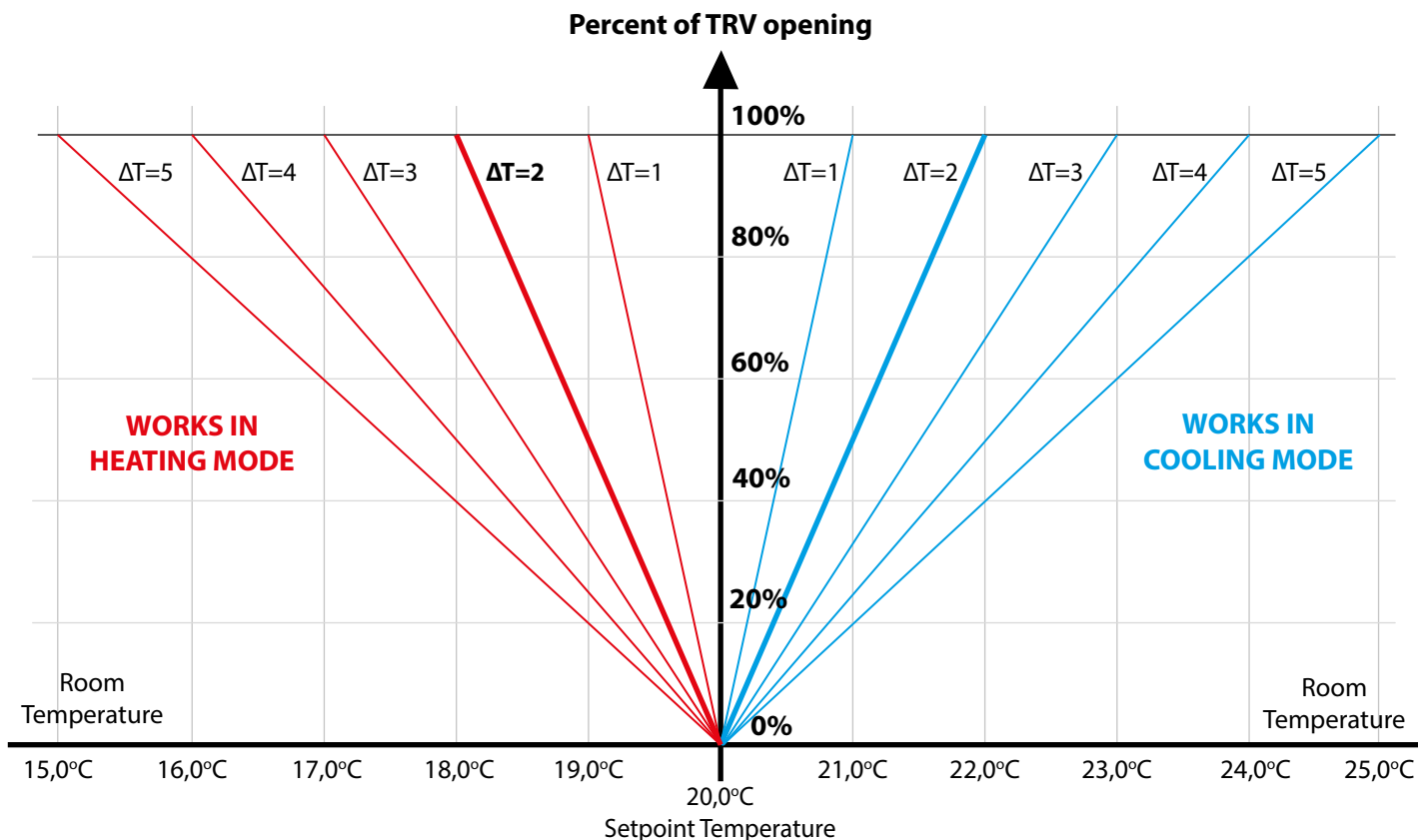

For heating mode, the above graph shows that the smaller the $\Delta RCWC$, the faster the response of the head and the faster the valve opening when the temperature drops.

For example (heating mode):

- if the parameter value is $\Delta RCWC = 2C$, the valve is opened to 100% when the temperature drops by 2 degrees from the set temperature.
- if the parameter value is $\Delta RCWC = 5C$, the valve opens at 100% when the temperature drops by 5 degrees from the setpoint.



NOTES:

In addition to the ΔT RCWC setting, the following factors should be taken into account, which have a great influence on the stability of the room temperature:

- correct connection of the radiator in the system
- hydraulic regulation (flow rate) on the valve inserts (radiator valves) to obtain the correct radiator output in the room
- temperature value of the heating medium
- quality of thermostatic radiator inserts (valves)

21.11 Heating/Cooling mode selection

This function allows the thermostat's operating mode to be selected:

(a) operation of the system for heating (factory setting),

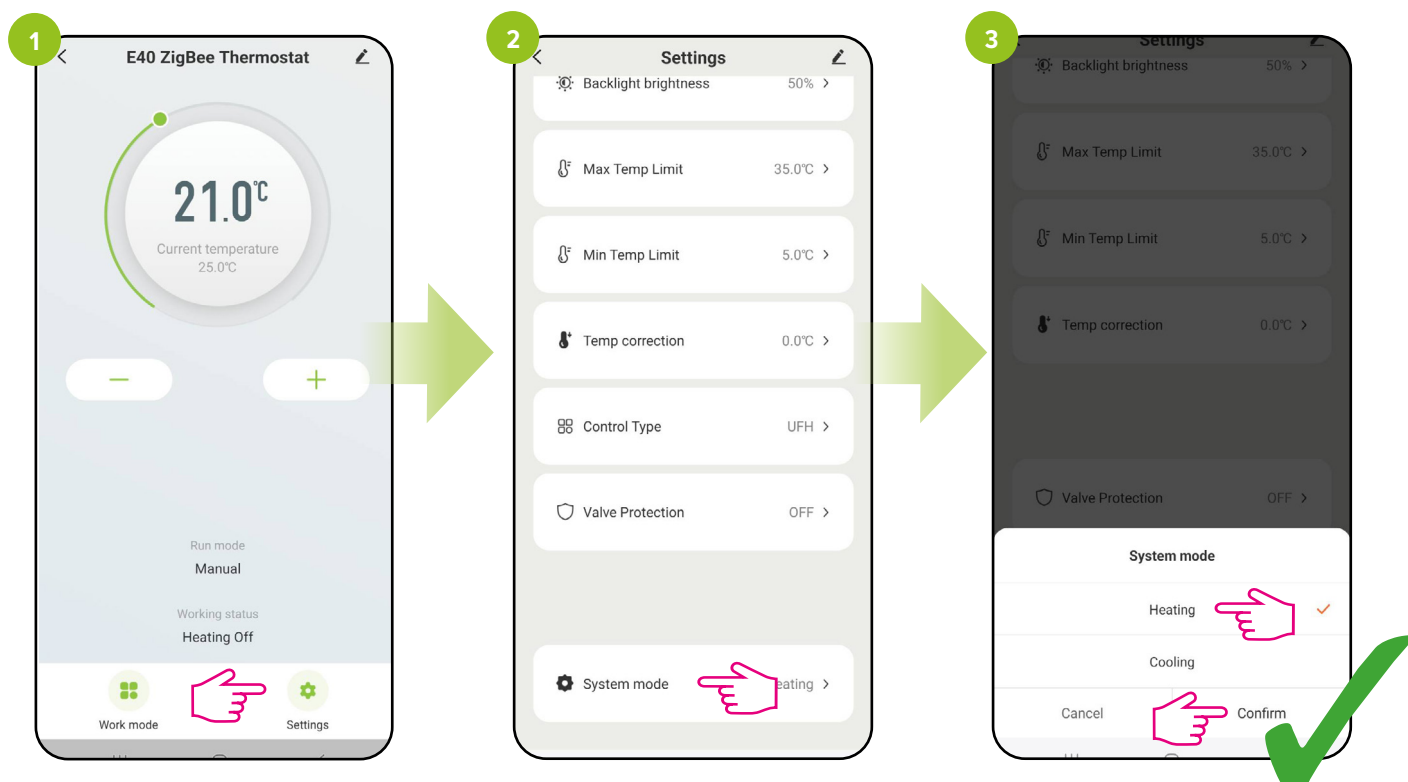

Select the „Settings” option.

Click on „System mode”.

Select „Heating”.
Then click „Confirm”.

(b) operation of the cooling mode.

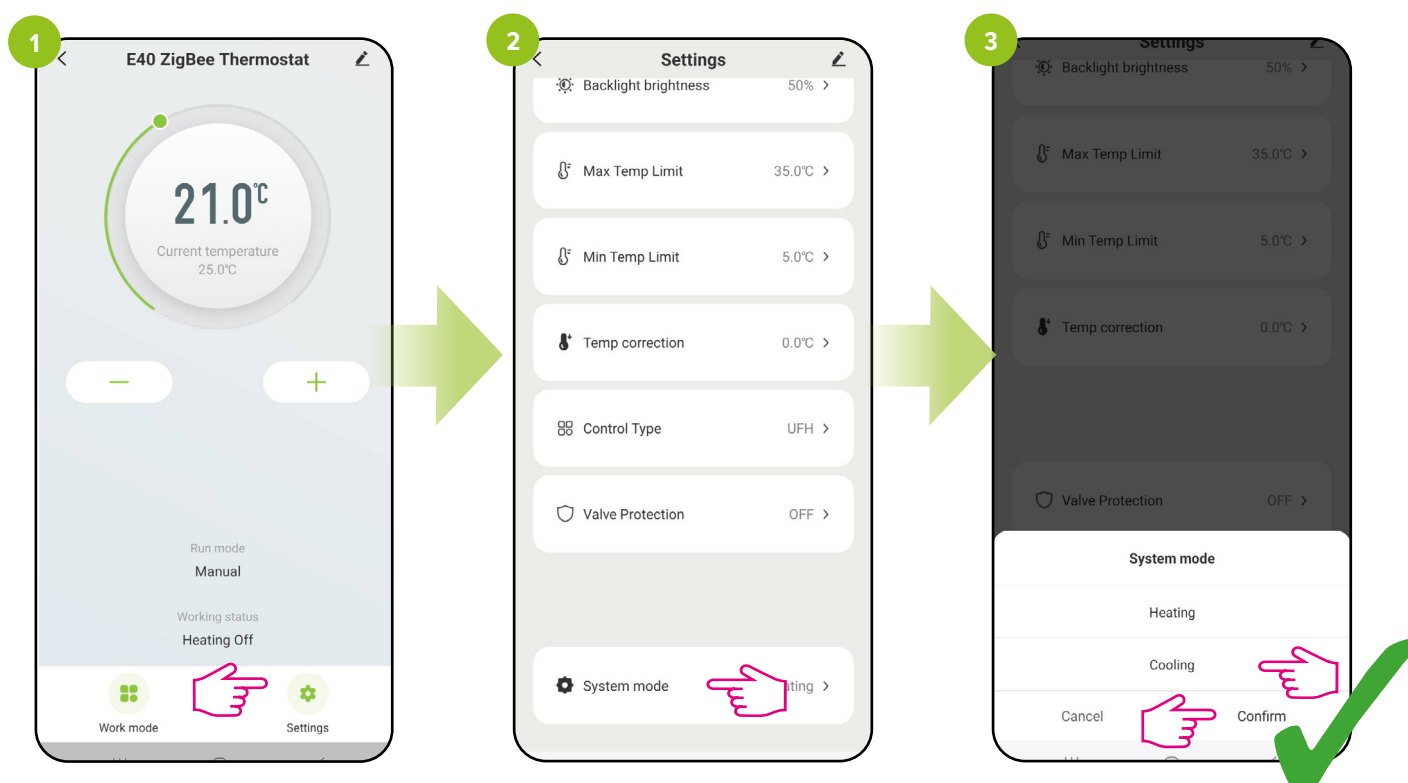

Select the „Settings” option.

Click on „System mode”.

Select „Cooling”.
Then click „Confirm”.

22. General management

22.1 Change the name, icon and location of the thermostat

Name the regulator, edit its icon or select the location of the house where it should be located:

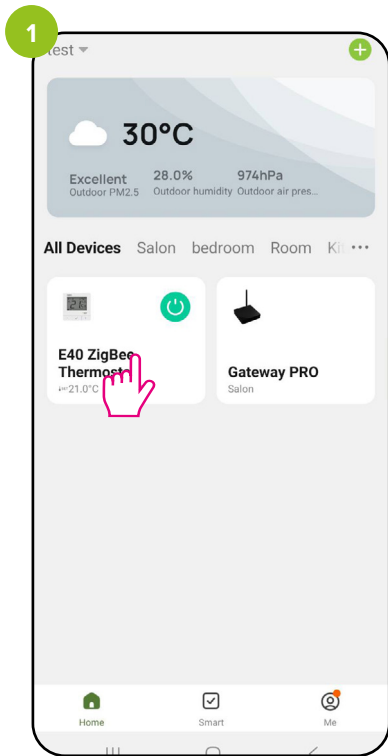

Enter the thermostat interface.

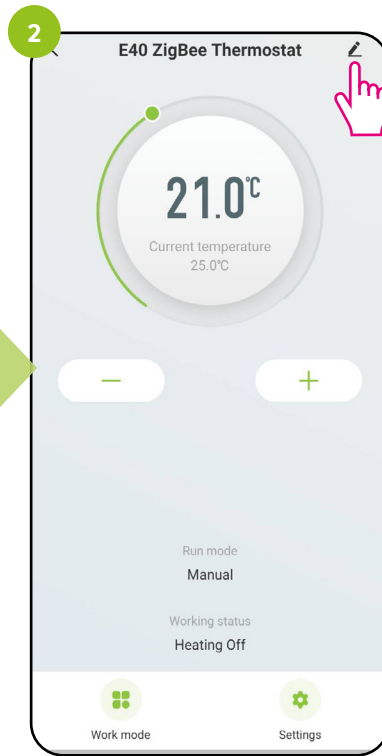

Click on the pencil icon in the upper corner.

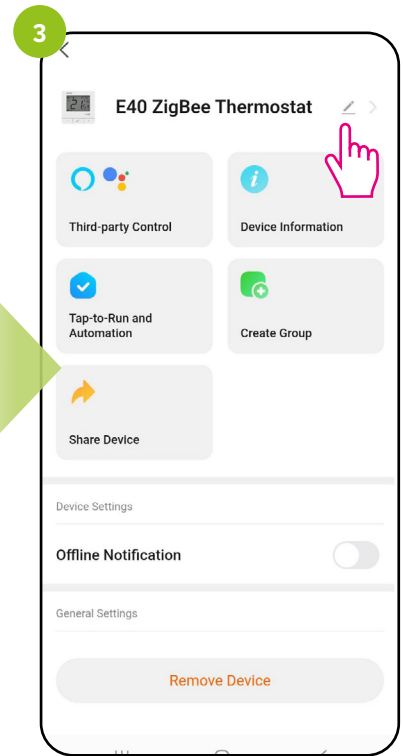

Click the pencil again.

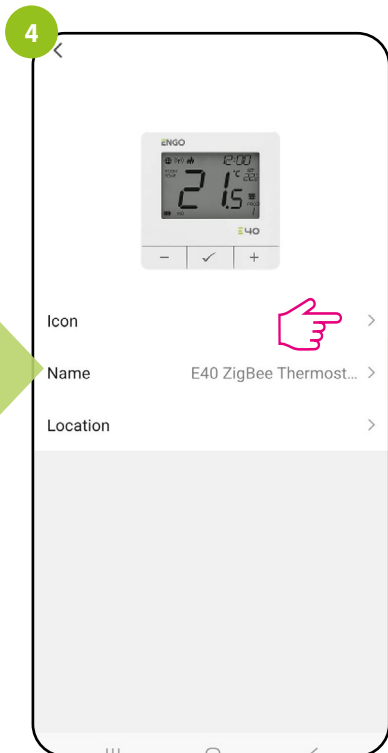

Go into the icon settings.

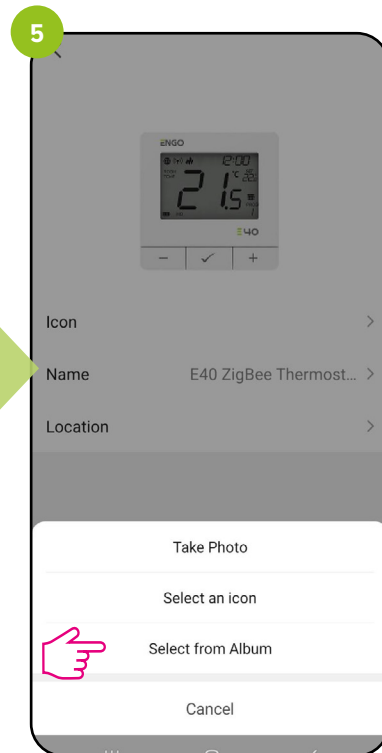

Take a photo or select an image from your local album.

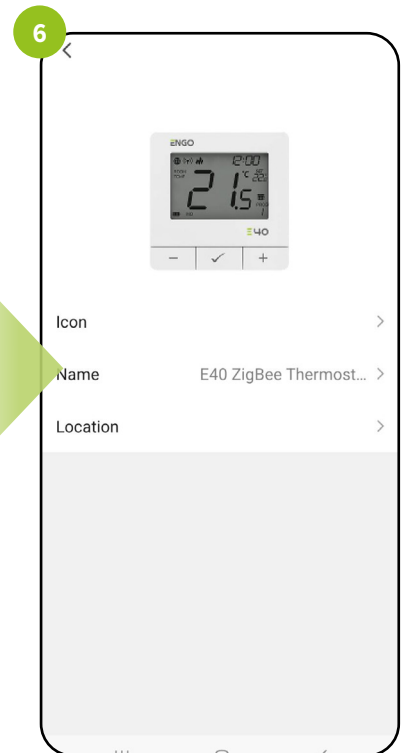

Open the name editing window.

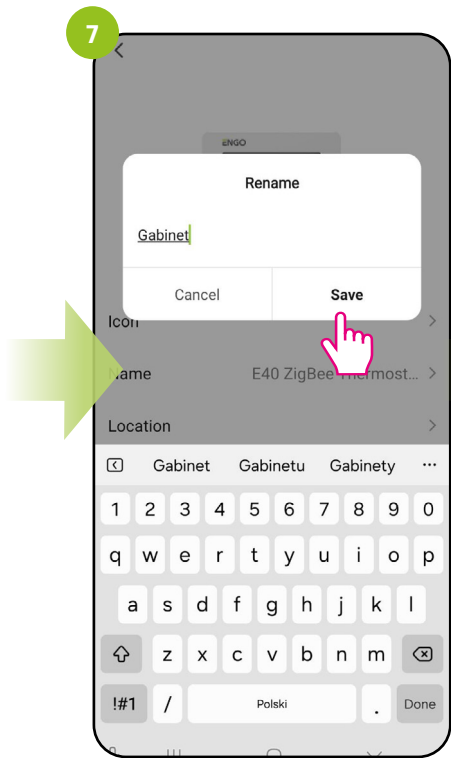

Enter a name and click save.

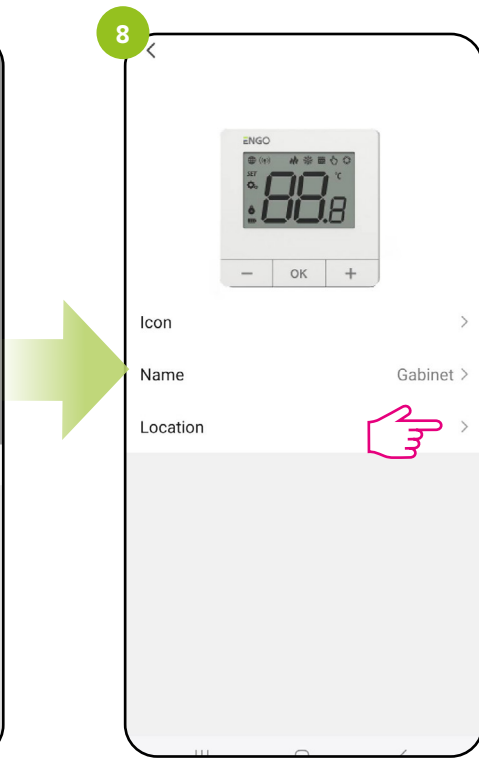

Determine the room in which the thermostat is to be located.

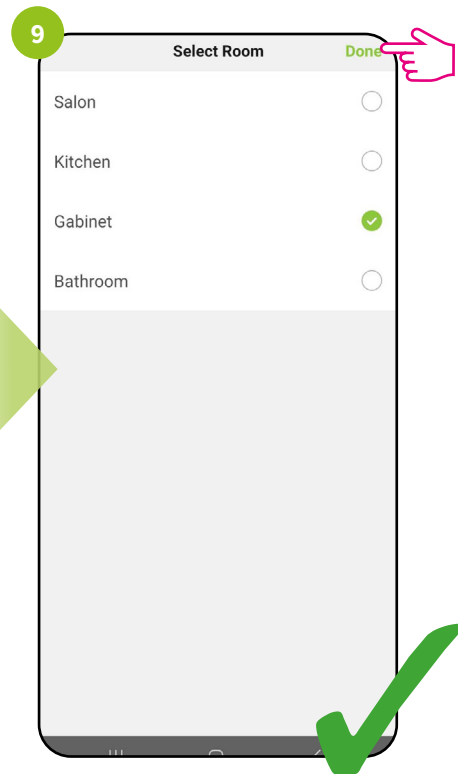

Select the location and click „Done” in the top right corner.

22.2 Supported external control (voice assistants)

22.2.1 Integration with Amazon Alexa

To integrate ENGO Smart products with your Amazon Alexa account, follow these steps:

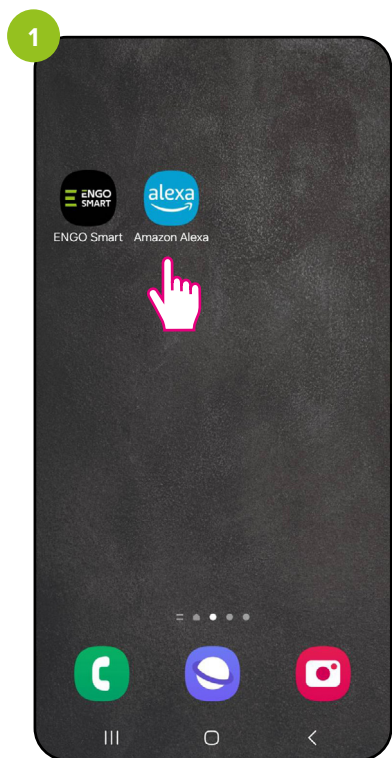

Install the Amazon Alexa app.

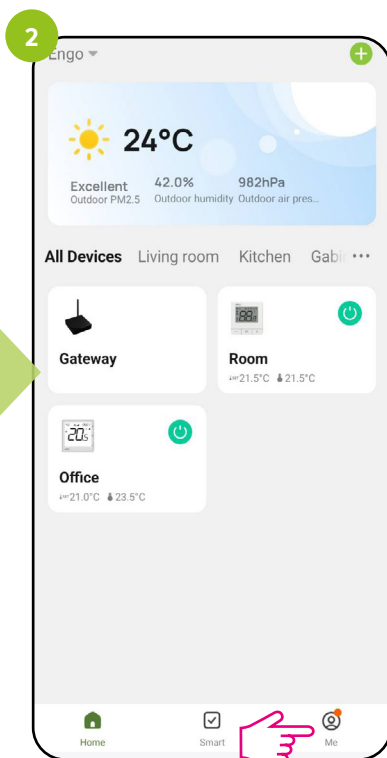

Go to the „Me“ tab.

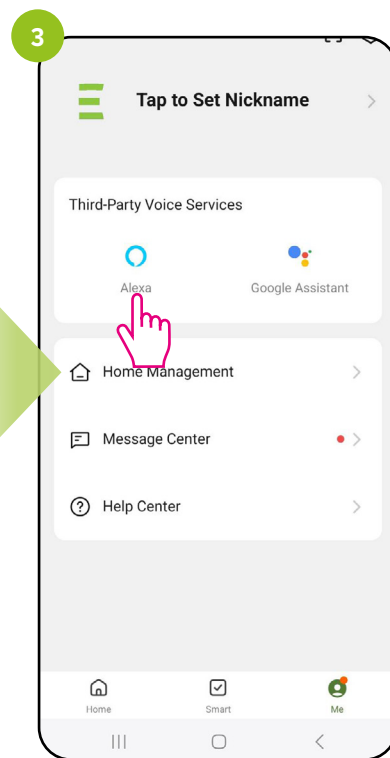

Go to the Alexa service.

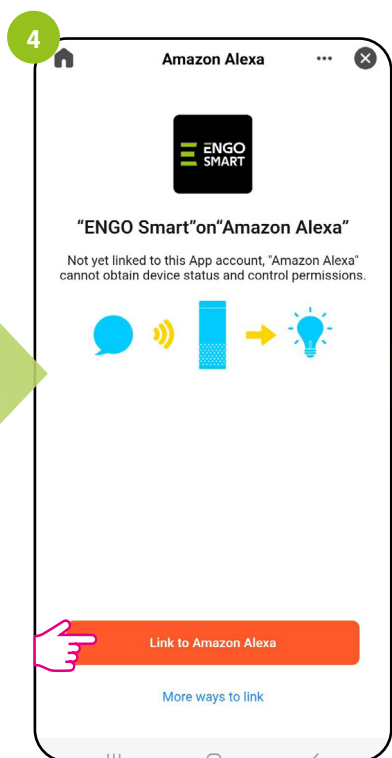

Click „Link to Amazon Alexa“.

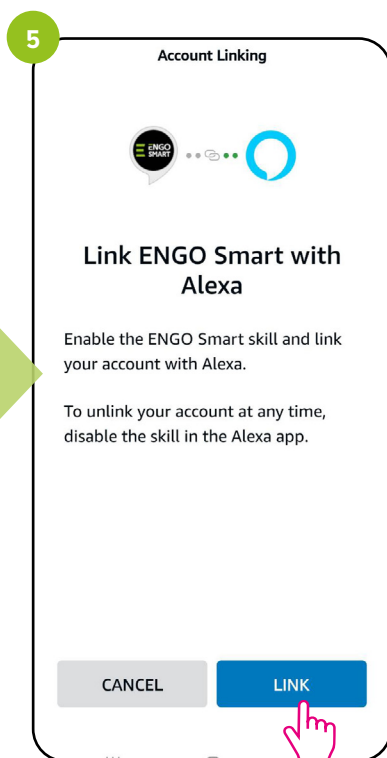

Connect the devices by clicking „LINK“.



The connection was successful, end by clicking „Done“.

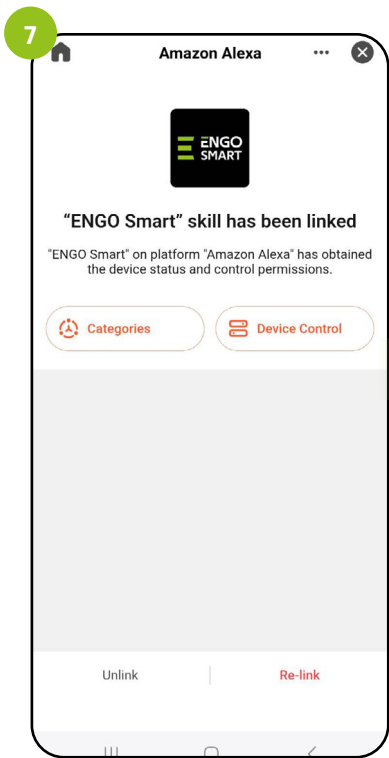

The devices have been linked to Alexa.

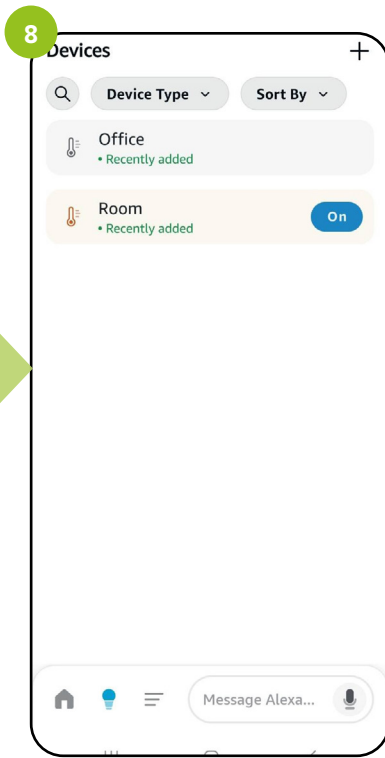

Devices are visible in the Alexa app.

Triggering the voice assistant:

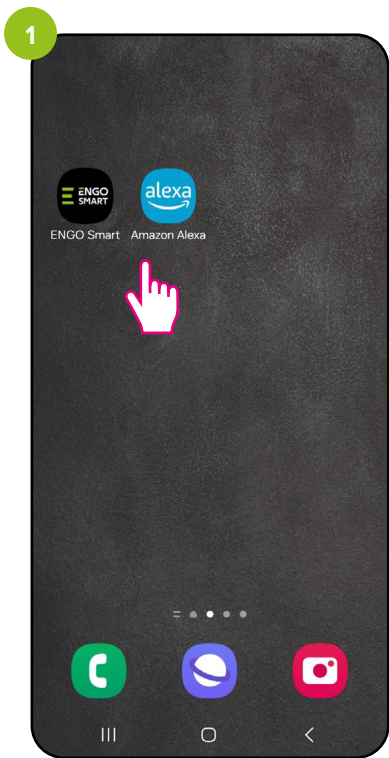

Click the Alexa assistant icon.

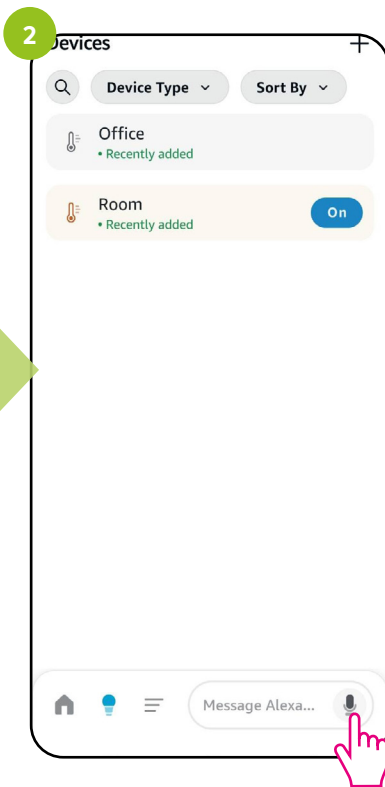

Click on the microphone icon.

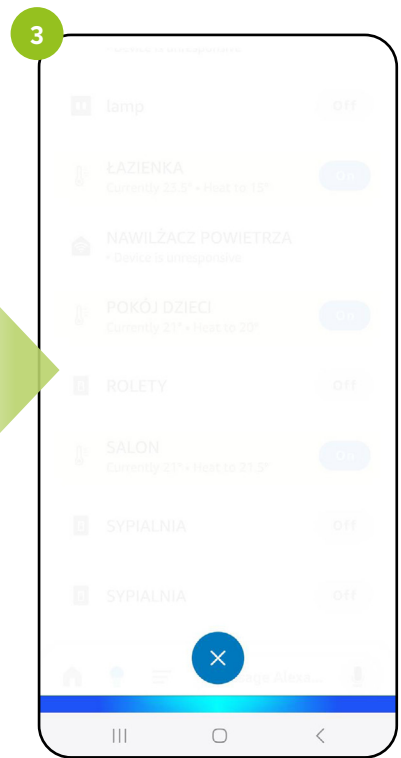

Tell us what you would like to control.

E40 - List of voice commands for Amazon Alexa

Command	Explanation
Alexa, turn OFF <device name>	Turn off the thermostat
Alexa, turn ON <device name>	Turn on the thermostat
Alexa, what is the temperature of <device name>	Check the temperature measured by the thermostat
Alexa, set <device name> to HEAT mode	Change the operating mode to heating
Alexa, set <device name> to AUTO mode	Changing the operation mode to schedule
Alexa, set <device name> to COOL mode	Changing the operation mode to cool
Alexa, what is the target temperature of <device name>	Checking the temperature setpoint
Alexa, set <device name> to twenty degrees	Setting the temperature setpoint

22.2.2 Integration with Google Assistant

To integrate ENGO Smart products with your Google Home account, follow these steps:

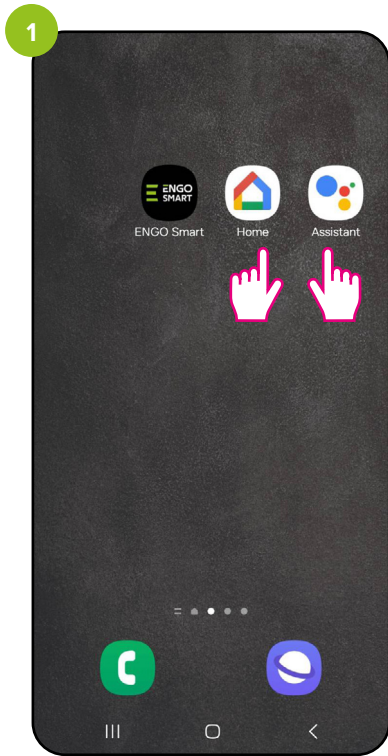

Install the Google Home app and Google Assistant.

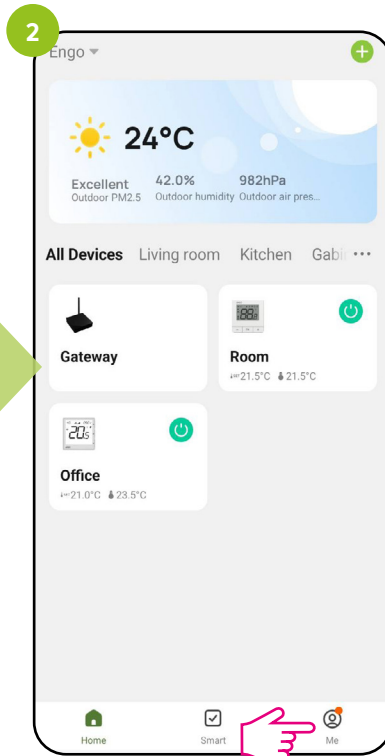

Go to the „Me” tab.

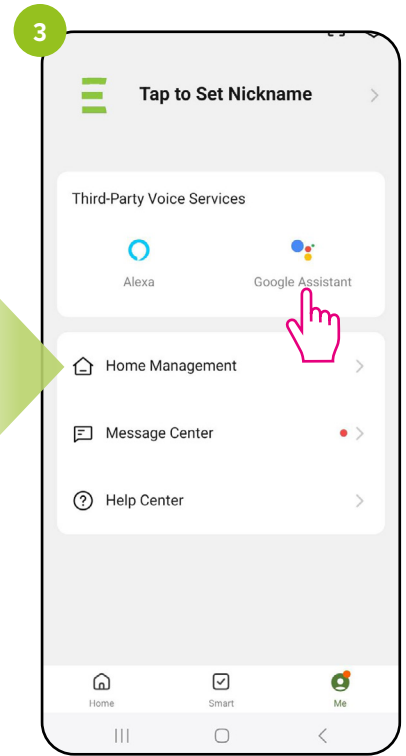

Go to the Google Assistant service.

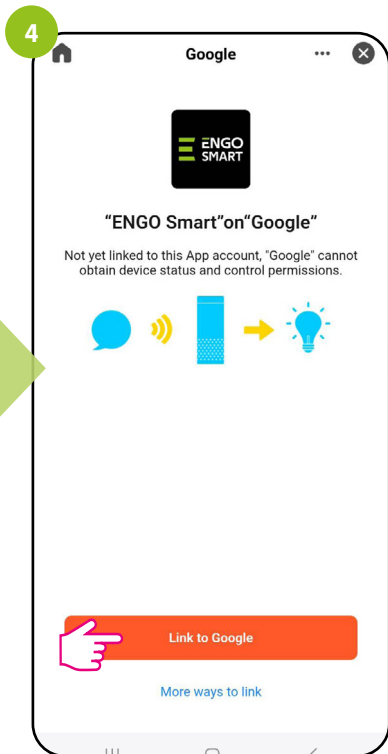

Make sure your phone is connected to the same Wi-Fi network as your devices added to your ENGO Smart account. Then click „Link to Google”.

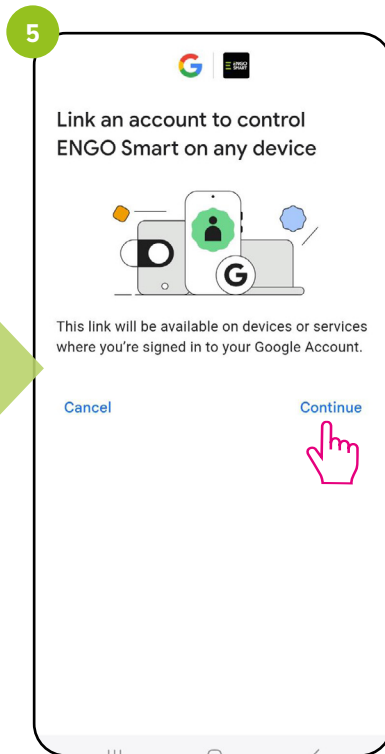

Click „Continue”.

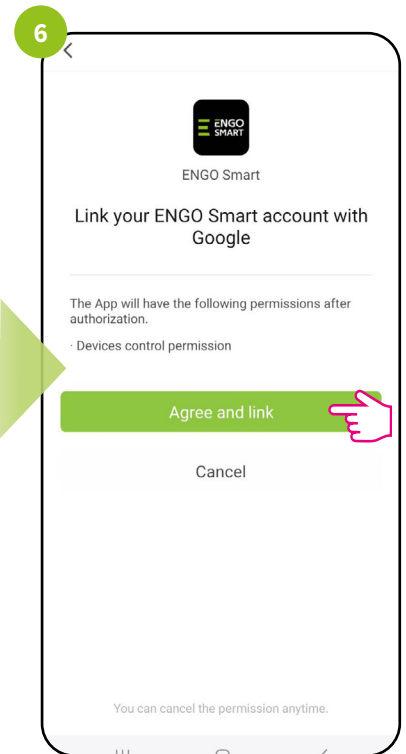

Consent is required to proceed further.

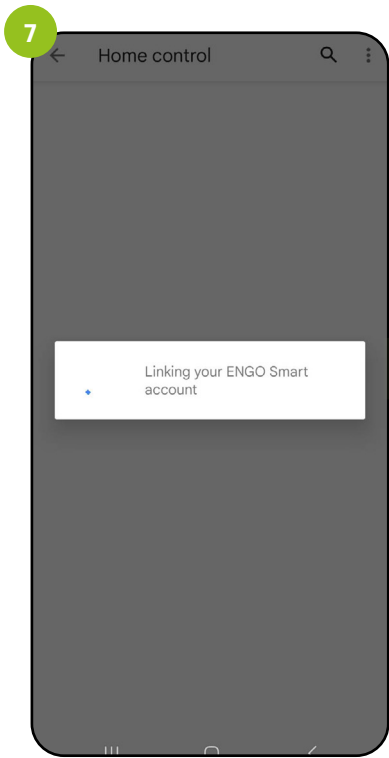

Wait for the account to be linked.

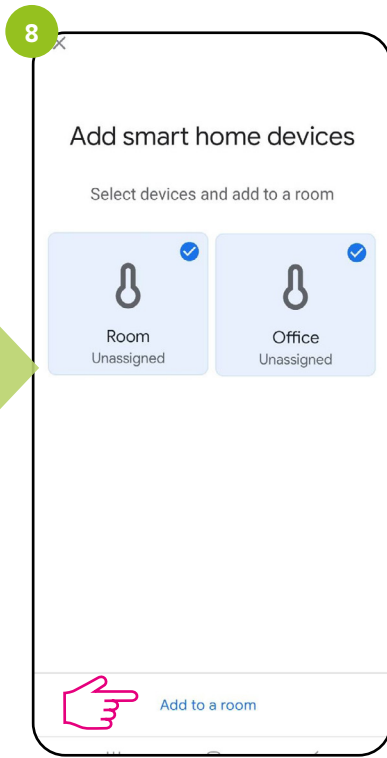

Select the devices and click „Add a room”.

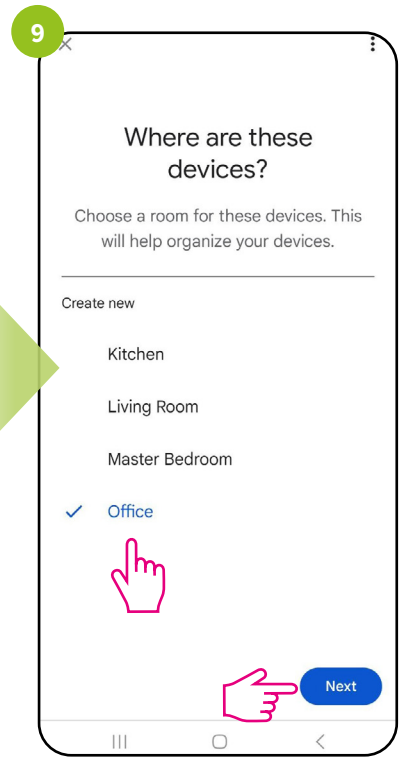

Choose a room and click „Next”.

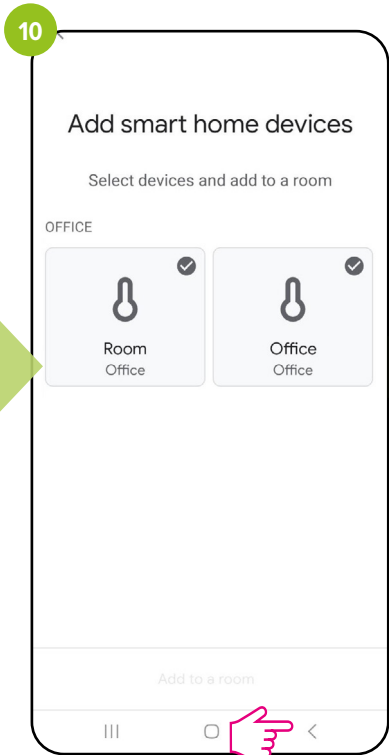

Go Back.

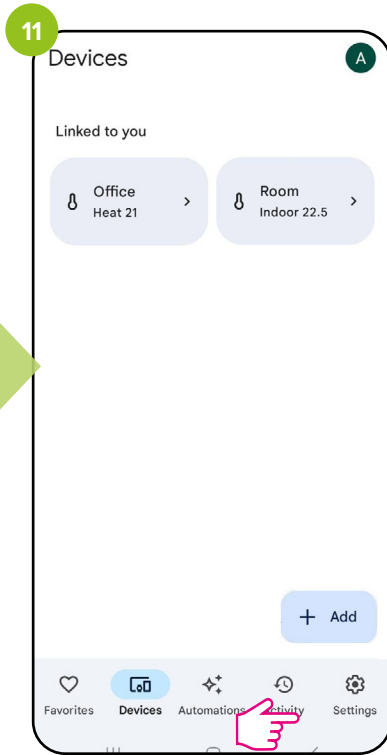

Configuration is complete.

Voice control with Google Assistant can be implemented in triggering the voice assistant:

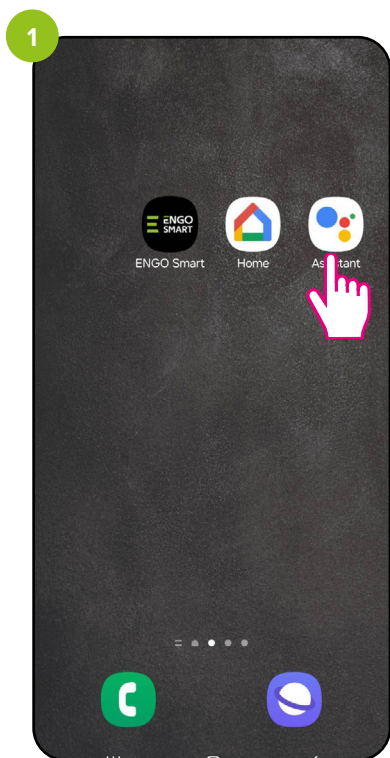

Click on the Google Assistant icon.

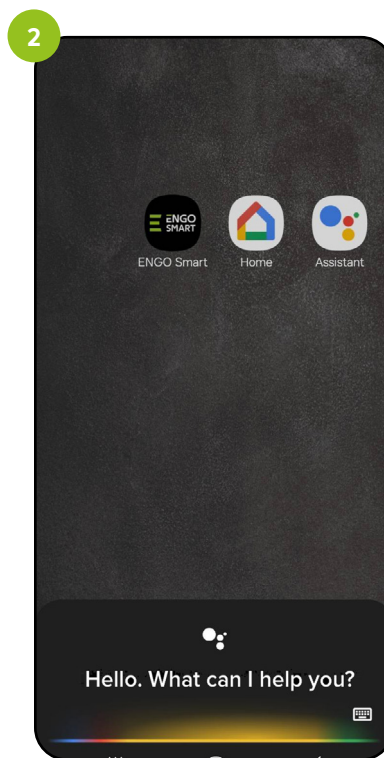

Tell us what you would like to control

E40 - List of voice commands for Google Home	
Command	Explanation
OK Google, turn off <device name>	Turn off thermostat
OK Google, turn on <device name>	Turn on thermostat
OK Google, what temperature is <device name>	Check measured and setpoint temperature
OK Google, change the mode of <device name> to HEAT	Change the operation mode to heating
OK Google, change the mode of <device name> to COOLING	Change the operation mode to cooling
OK Google, set <device name> to twenty degrees	Set the set temperature

 **NOTES:**

Voice control will be more effective if device names are easy for the voice assistant to say and understand.

22.3 Device information

The user will find detailed information about the device here, e.g. Virtual ID, MAC address, time zone in which the device is located. Check the steps below:

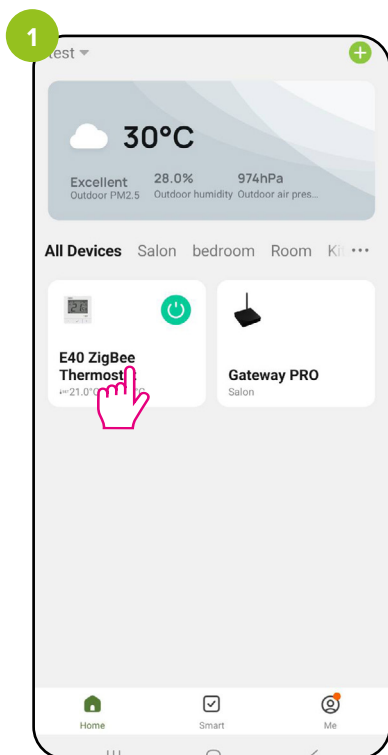

Enter the thermostat interface.

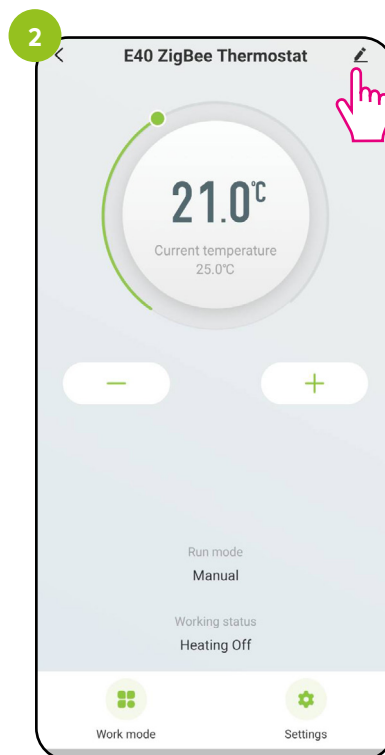

Click on the pencil icon in the upper corner.

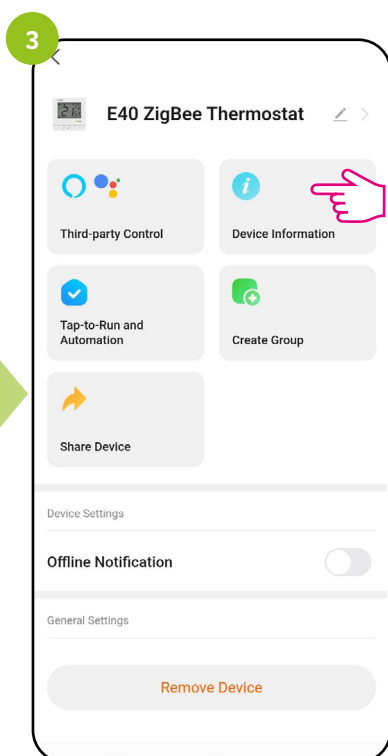

Select „Device information”.

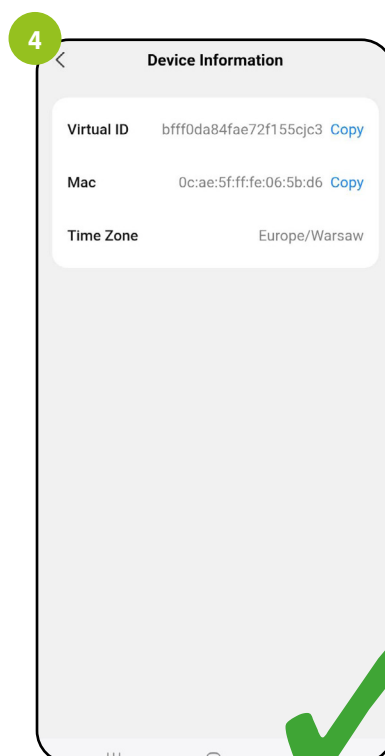

22.4 „Tap-To-Run” Scenery and „Automation” of related activities

The „Tap-To-Run” and „Automation” rules are a pre-configured set of actions defined by an easy-to-use interface. There are 2 main rule programming interfaces in the application that can be used for task settings:

- Tap-To-Run - with a single tap, make the complex rules system turn on the heating and lighting as soon as you enter the house,
- Automation - set up linked actions where one device will affect another without your intervention.

Example of setting up rules (automation) to turn the heat source on and off using ZigBee relay according to the status of the room thermostats. To create a rule to switch on a heat source follow the following steps:

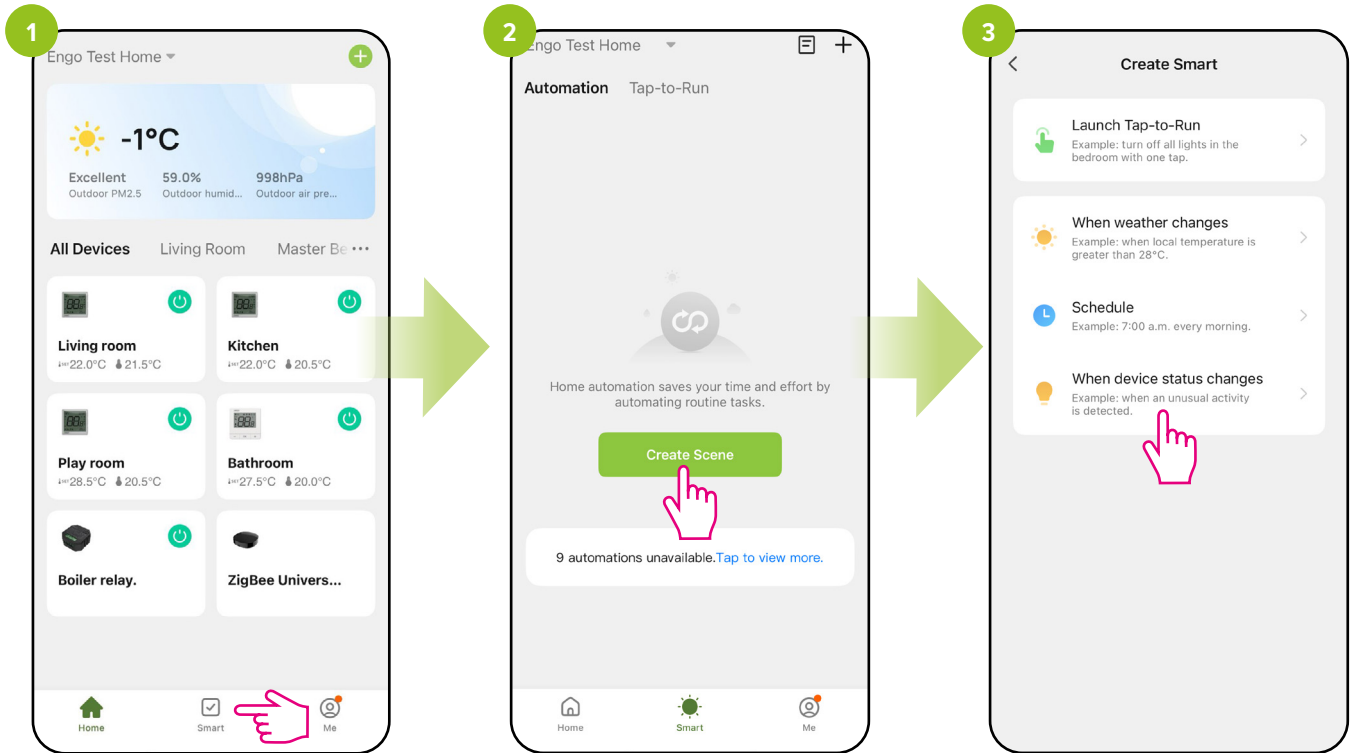

In the ENGO app, enter „Smart”.

Click „Create Scene”.

Select „When device status changes”.

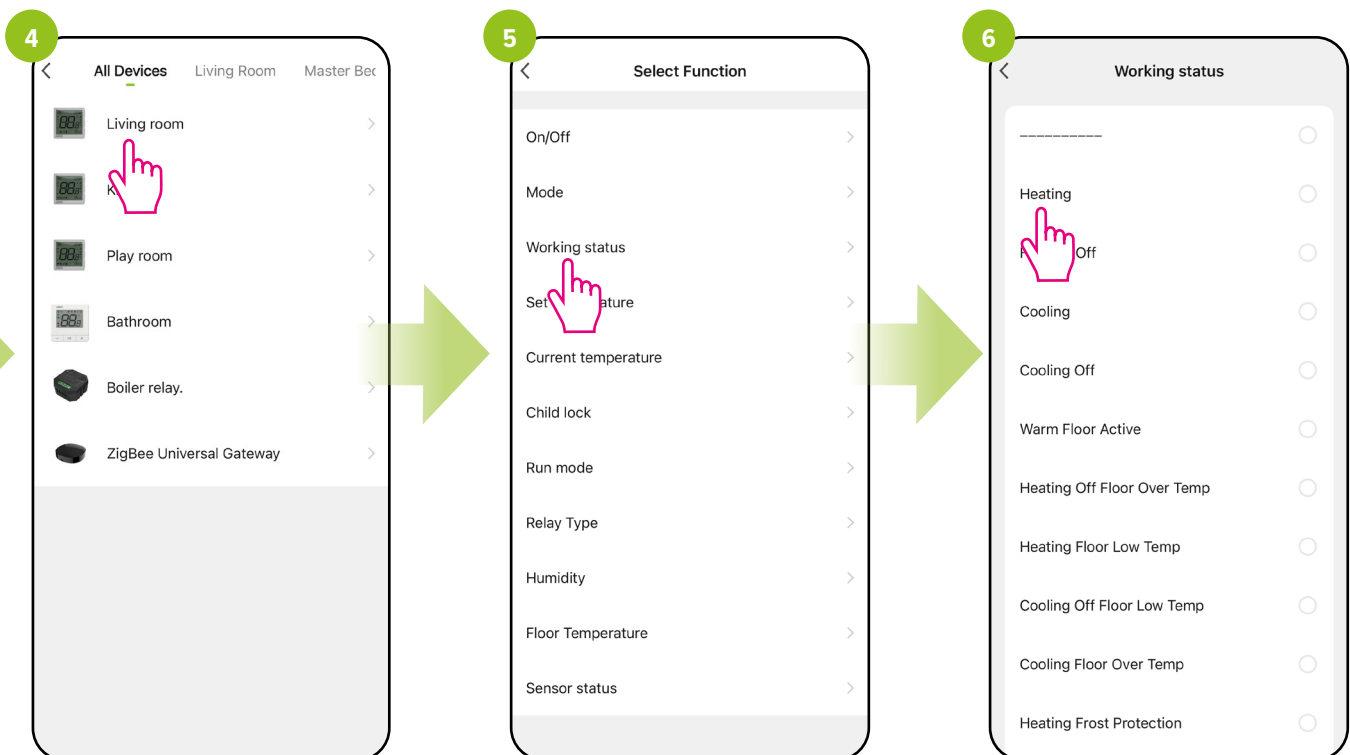

Select the first of the thermostats.

Select „Working Status”.

Select „Heating”.

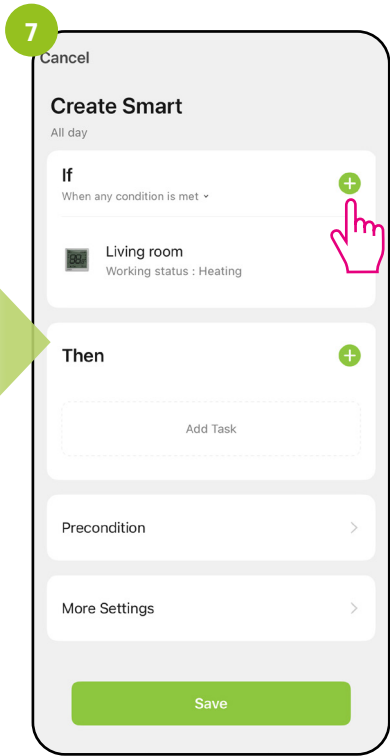

Add another condition.

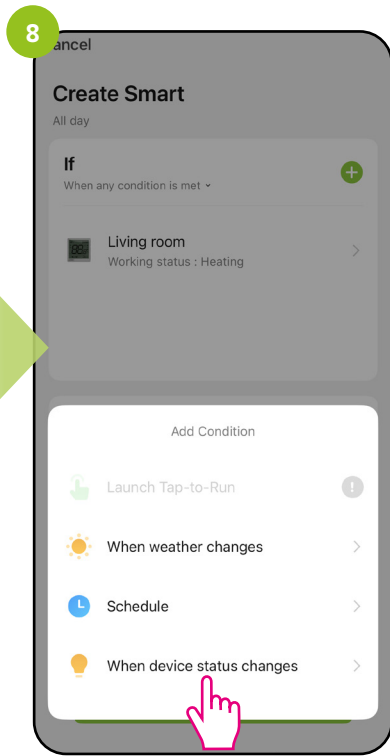

Select „When the status of the device changes”. Select the next regulator. If you have more than one regulator, you need to add each regulator to the rule.

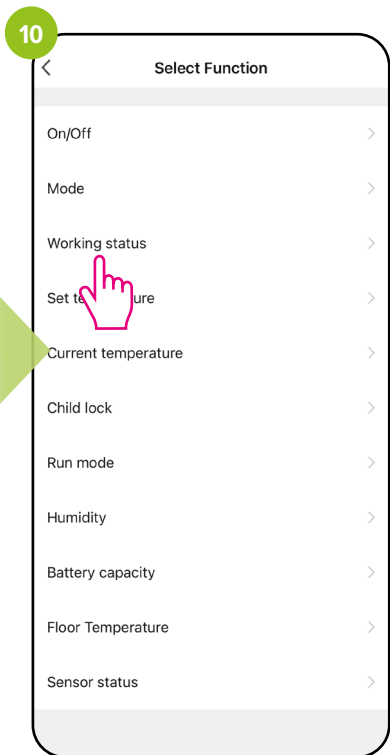
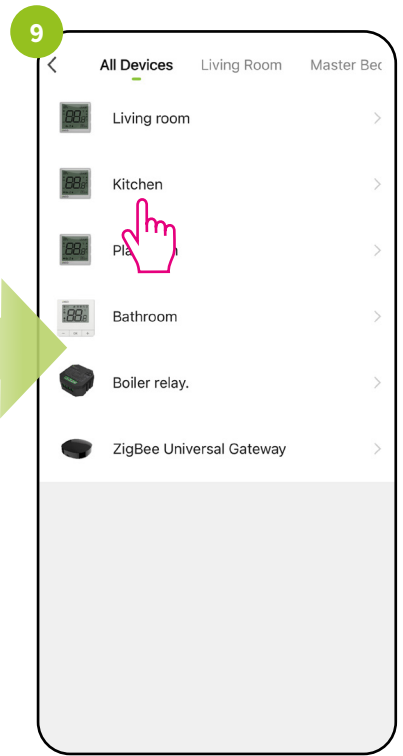

Select „Working Status”.

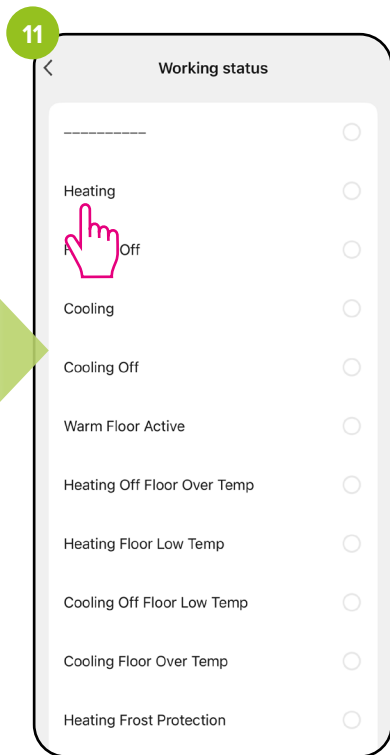

Select „Heating”.

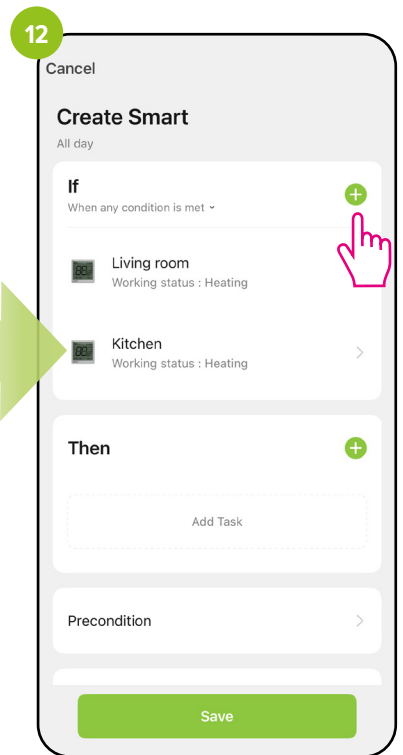

Add another condition.

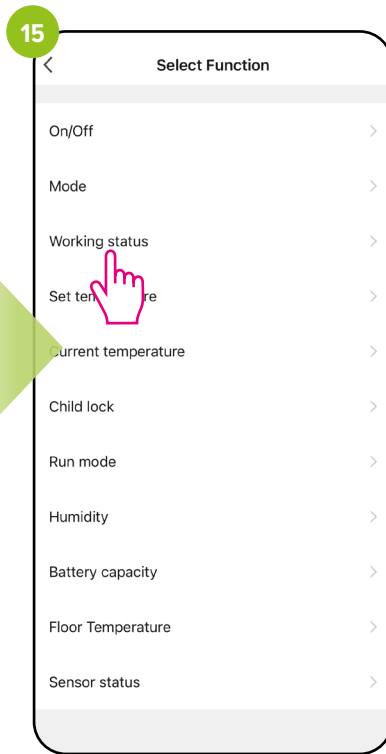
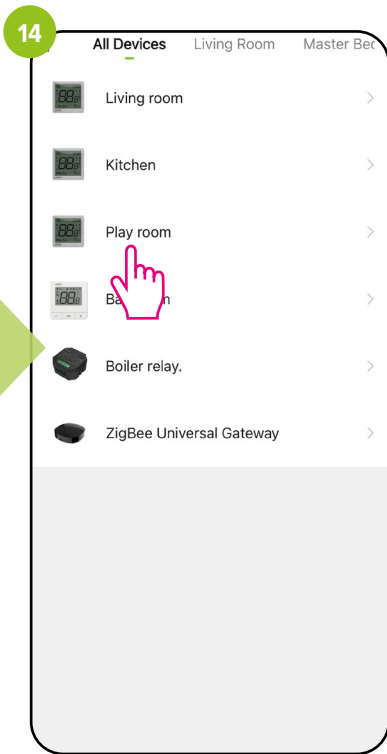
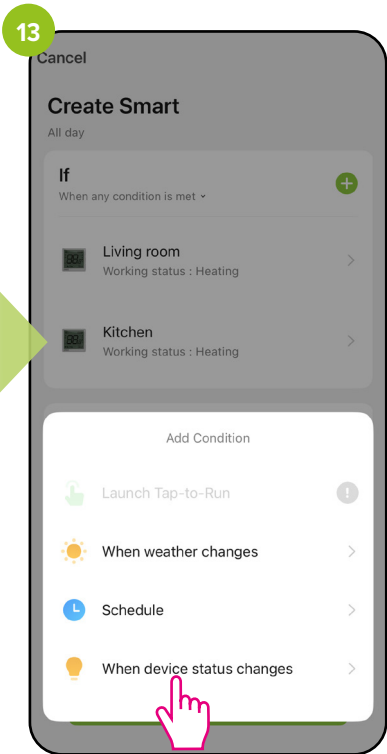

Select „When the status of the device changes“. Select the next regulator. If you have more than one regulator, you need to add each regulator to the rule.

Select „Working Status“.

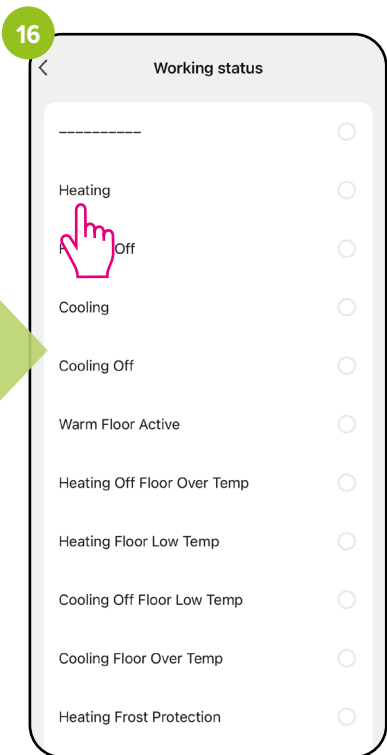

Select „Heating“.

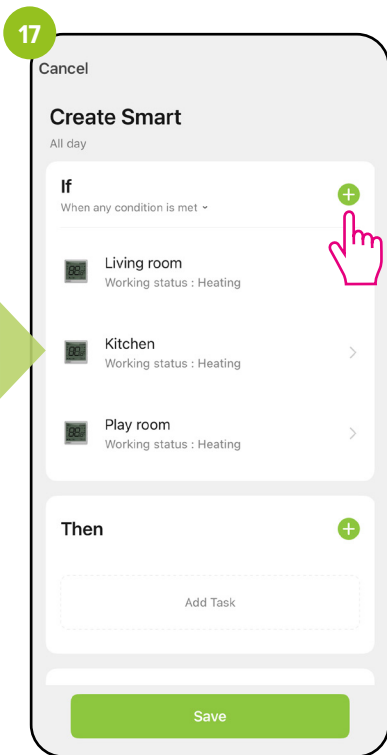

Add another condition.

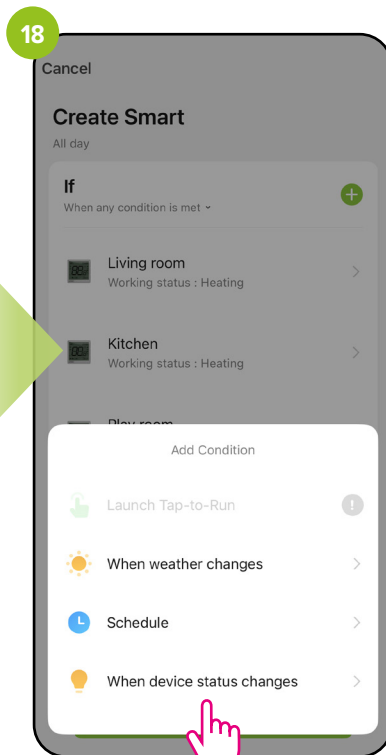

Select „When the status of the device changes“.

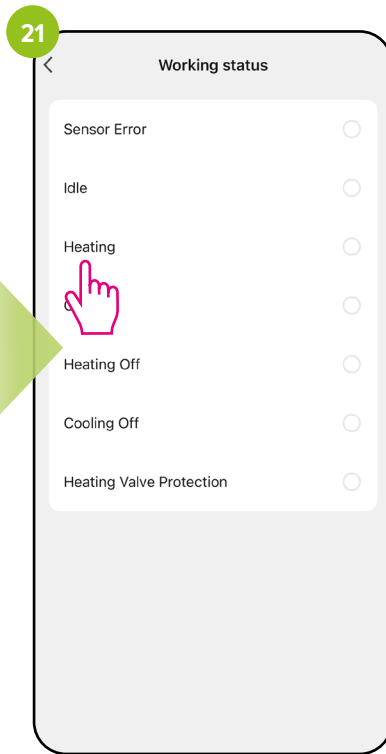
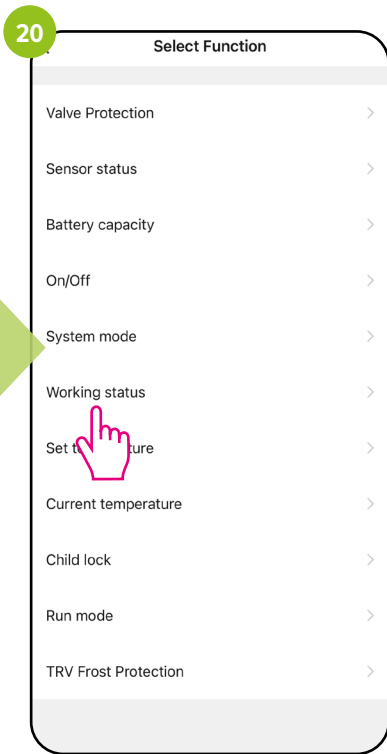
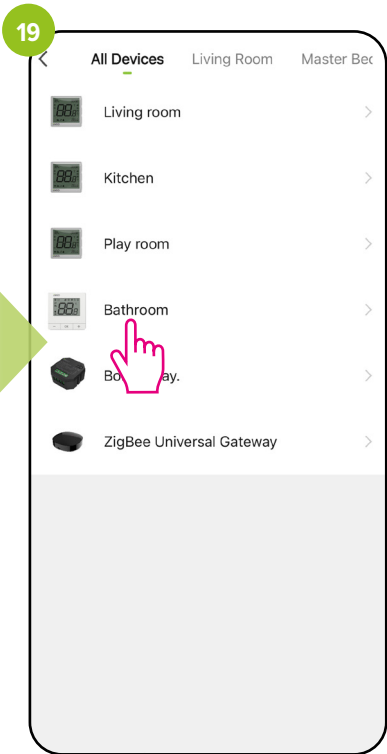

Select the next regulator. If you have more than one regulator, you need to add each regulator to the rule.

Select „Working Status“.

Select „Heating“.

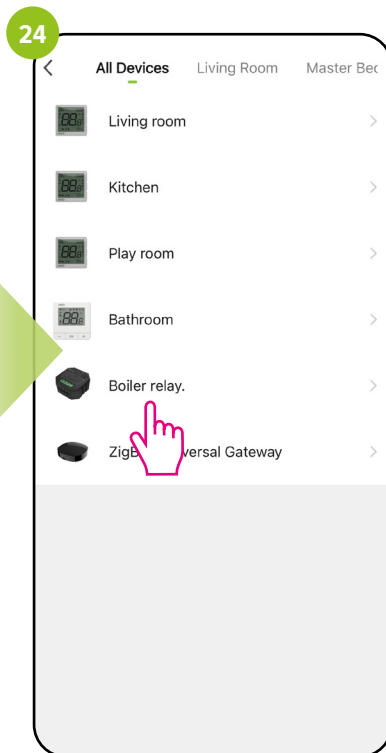
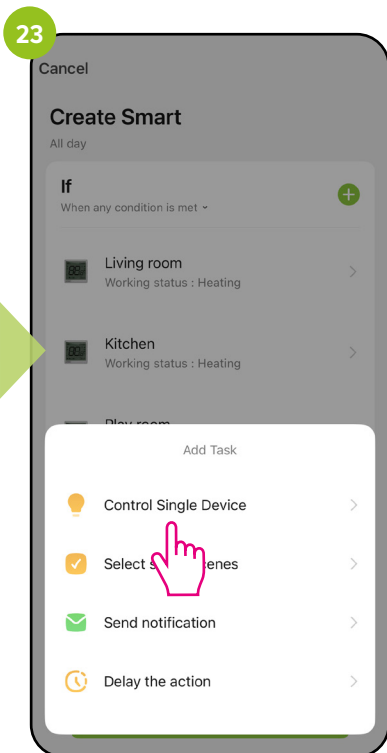
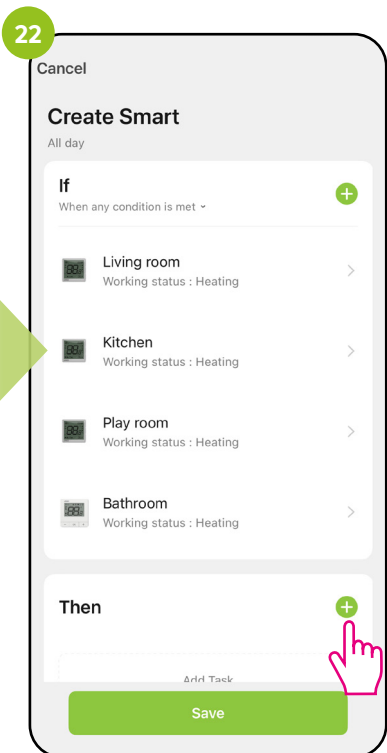

Add an action to perform.

Select „Control Single Device“.

Select the relay to control the heat source.

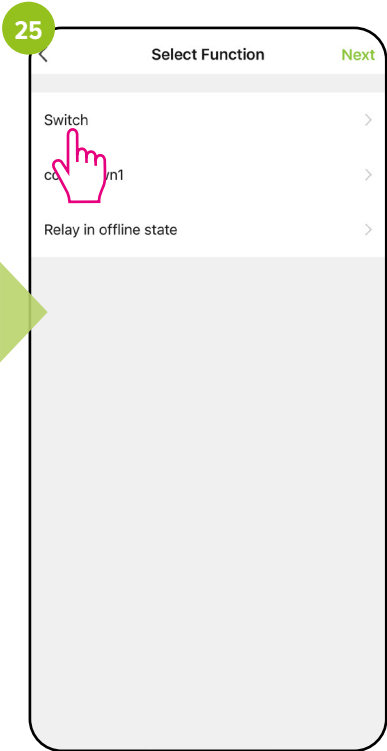

Select „Switch“.

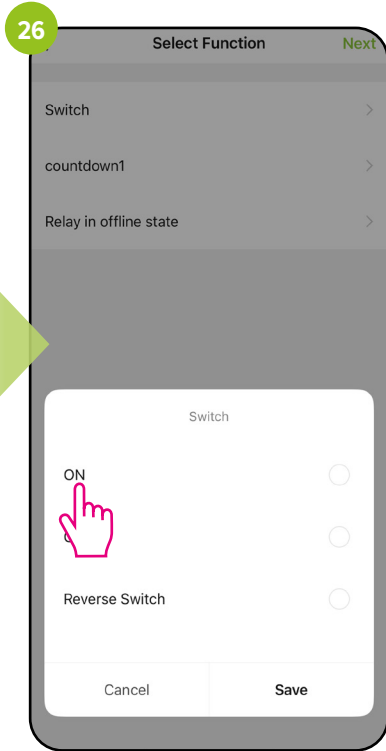

Select „ON“ .

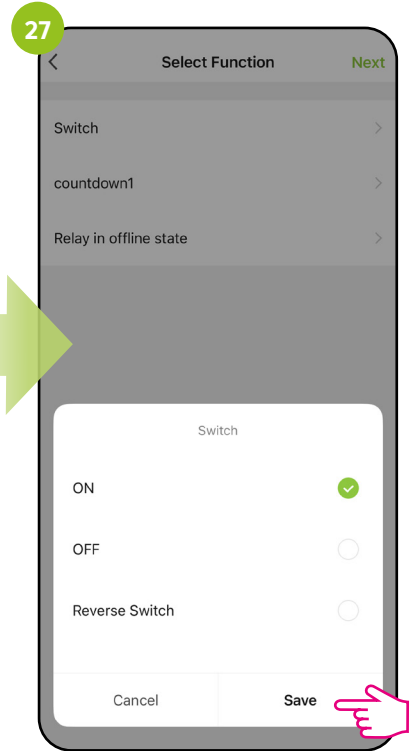

Click „Save“.

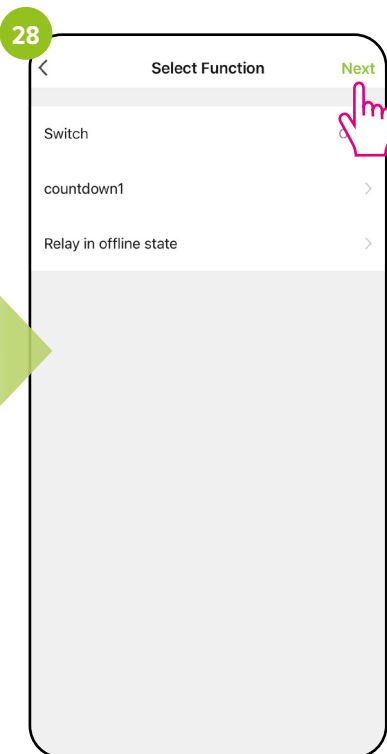

Click „Next“.

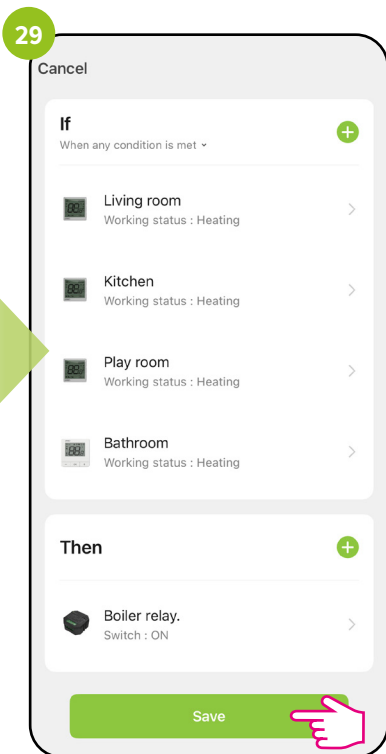

Save the automation.

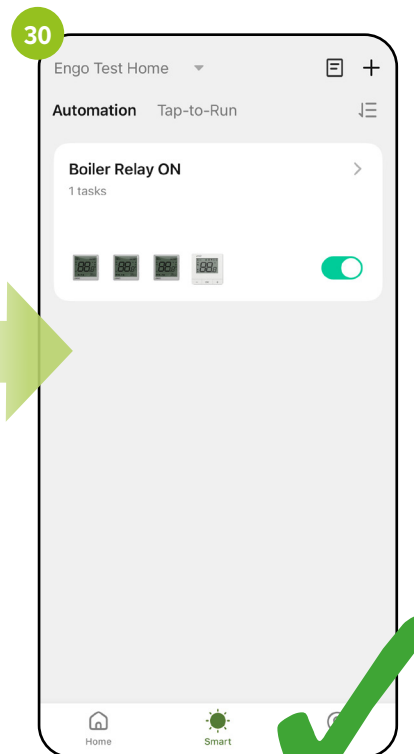

The heat source inclusion rule has been created.

To create a rule to exclude a heat source, follow the steps below:

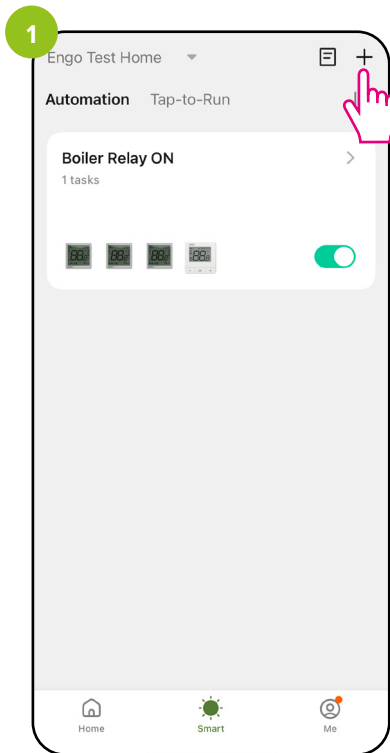

Add another scene.

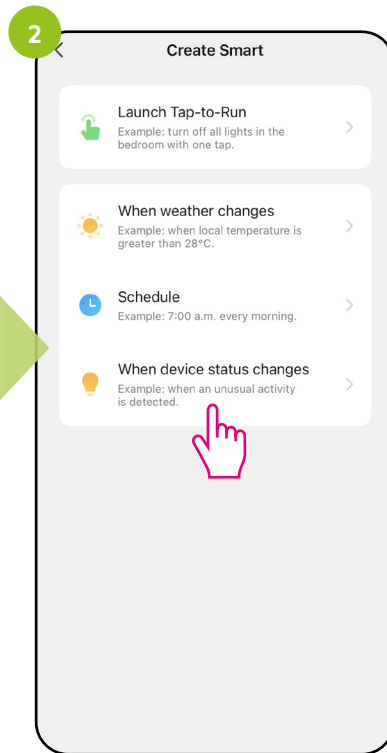

Select „When the status of the device changes”.

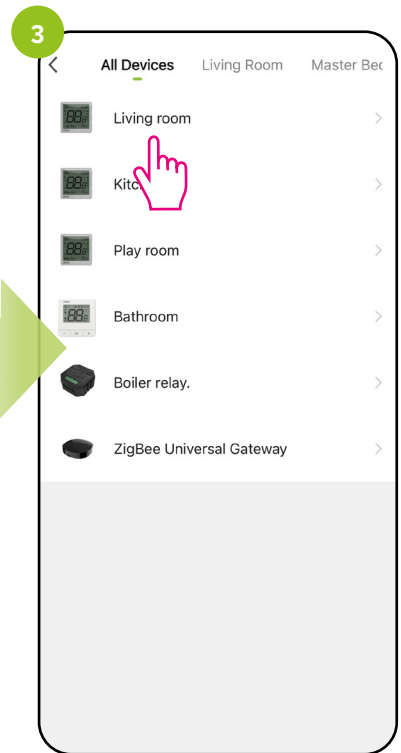

Select the first of the thermostats.

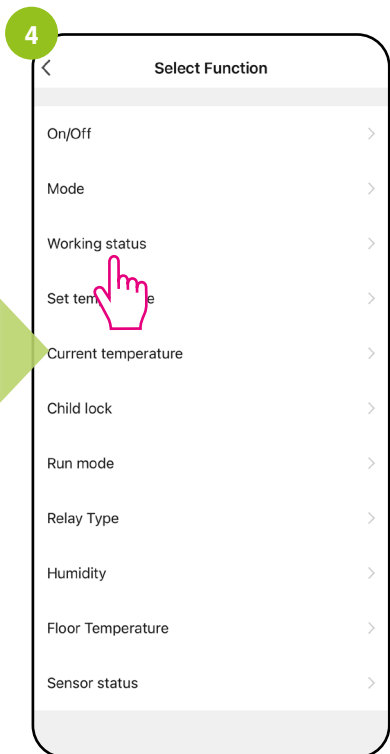

Select „Working Status”.

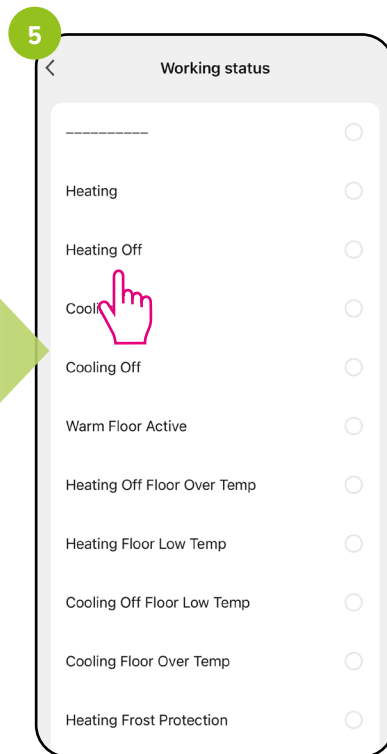

Select „Heating off”.

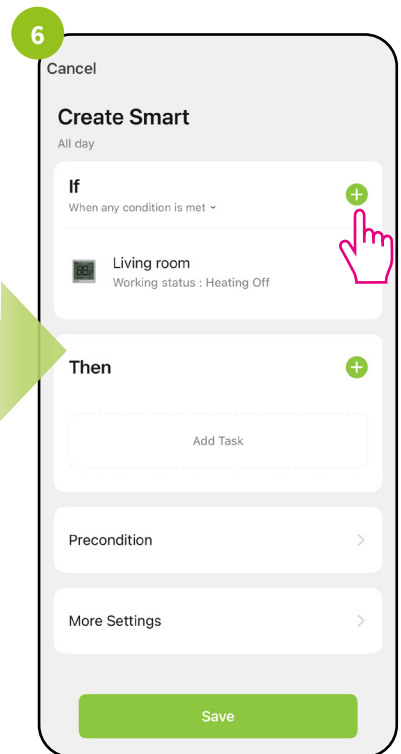

Add another condition.

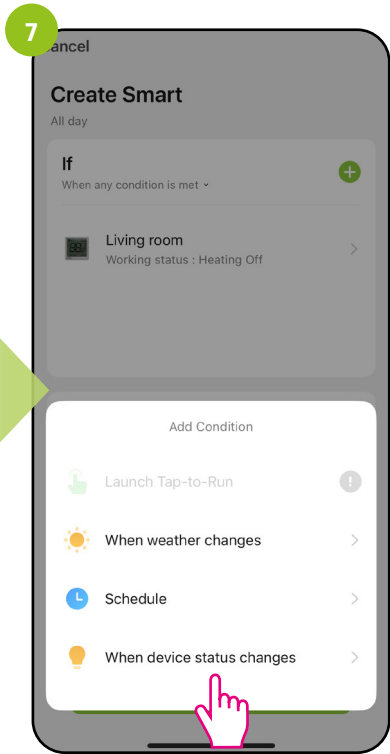

Select „When the status changes device”.

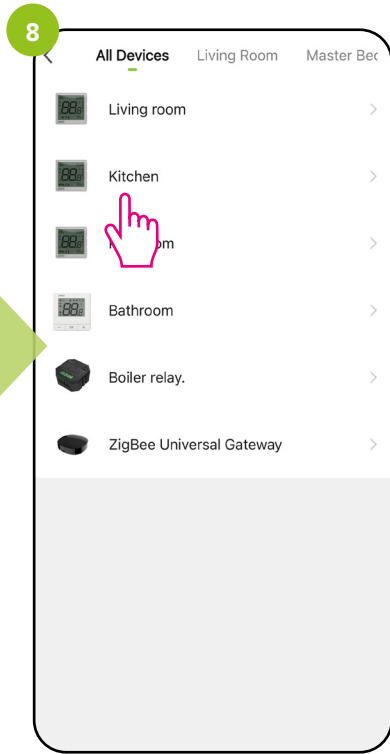

Select the next regulator. If you have more than one regulator, you need to add each regulator to the rule.

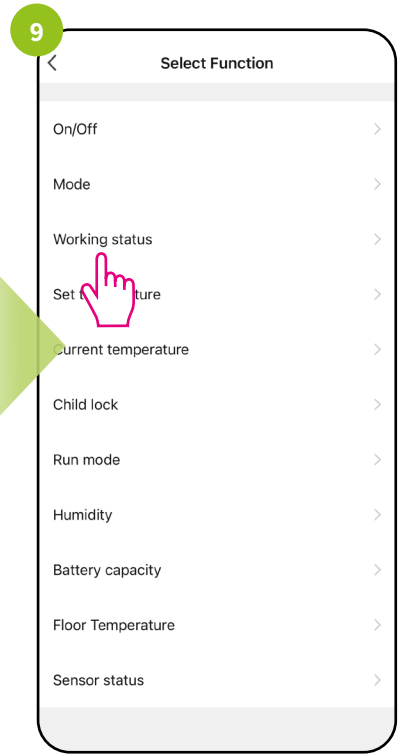

Select „Working Status”.

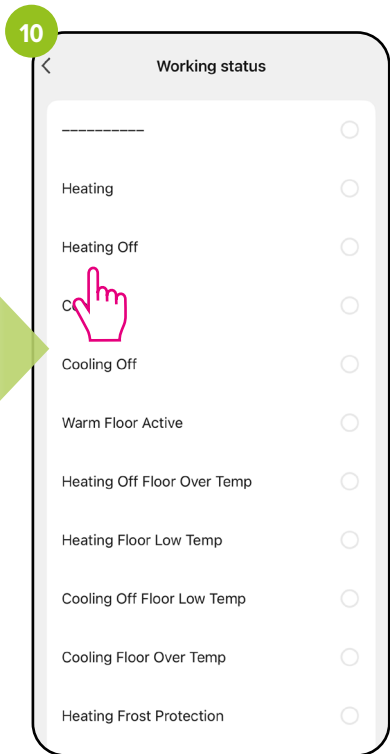

Select „Heating off”.

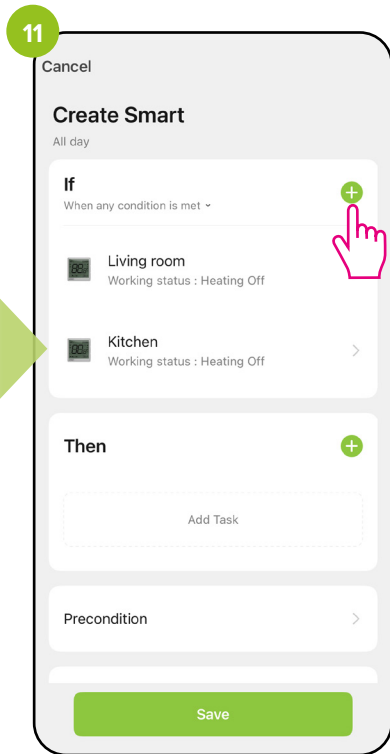

Add another condition.

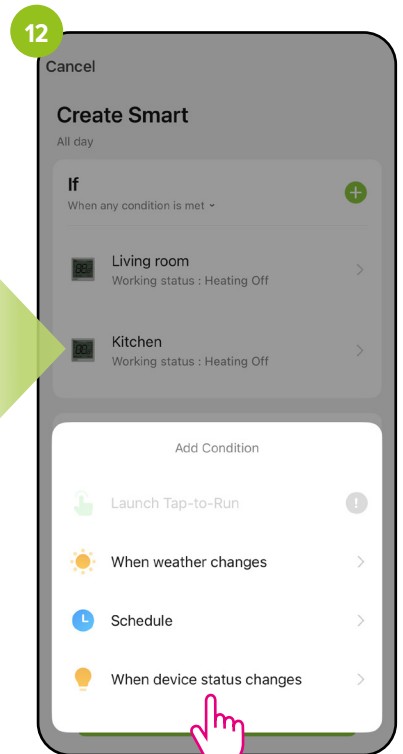

Select „When the status changes device”.

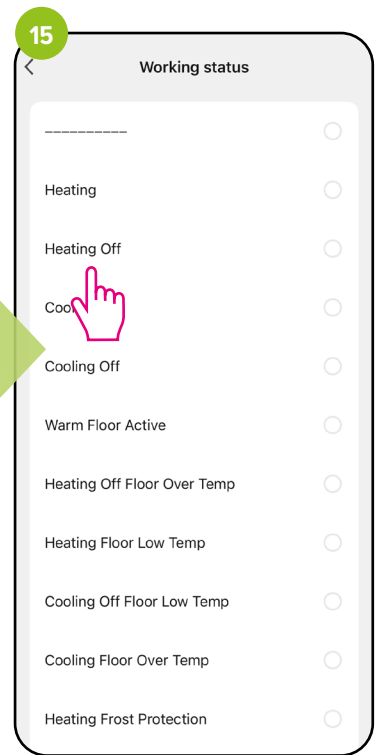
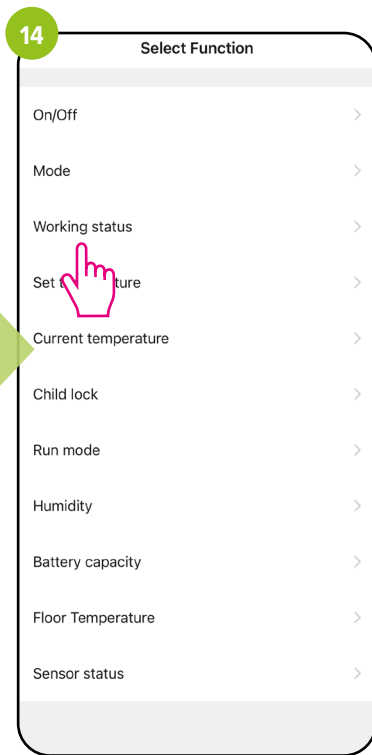
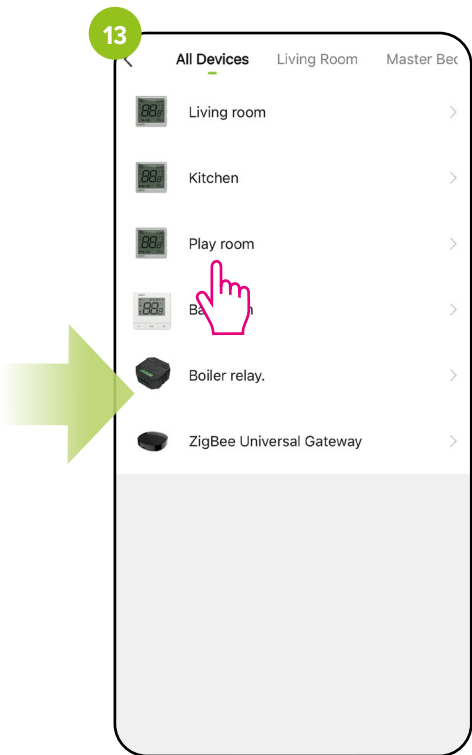

Select the next regulator. If you have more than one regulator, you need to add each regulator to the rule.

Select „Working Status“.

Select „Heating off“.

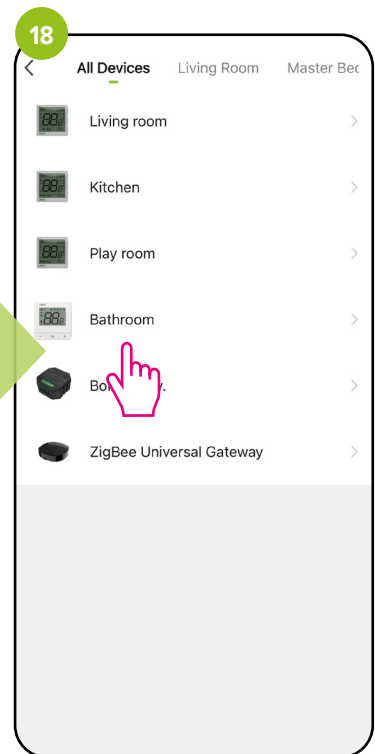
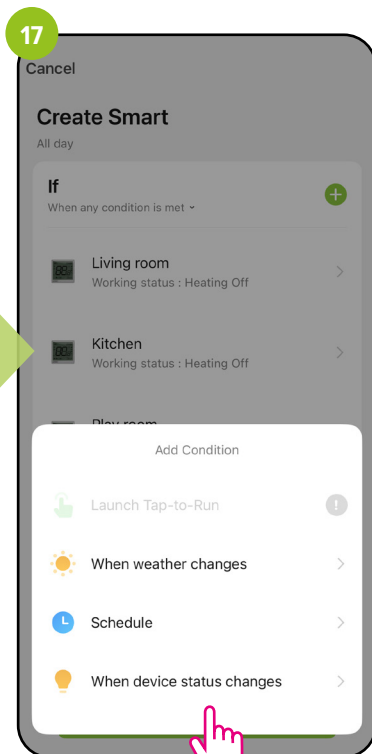
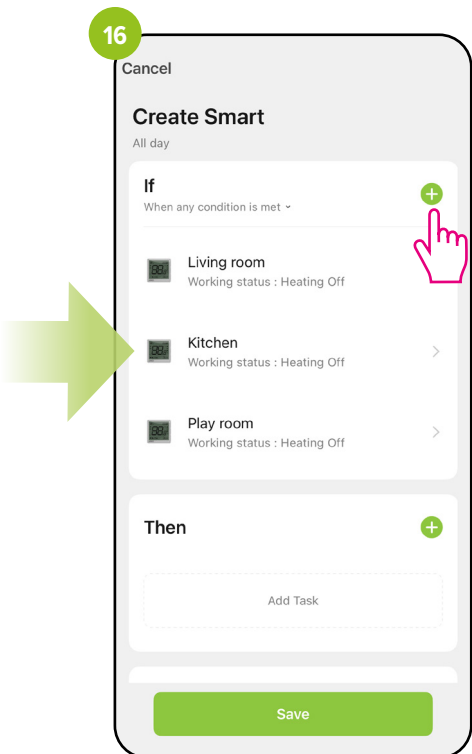

Add another condition.

Select „When the status changes device“.

Select the next regulator. If you have more than one regulator, you need to add each regulator to the rule.

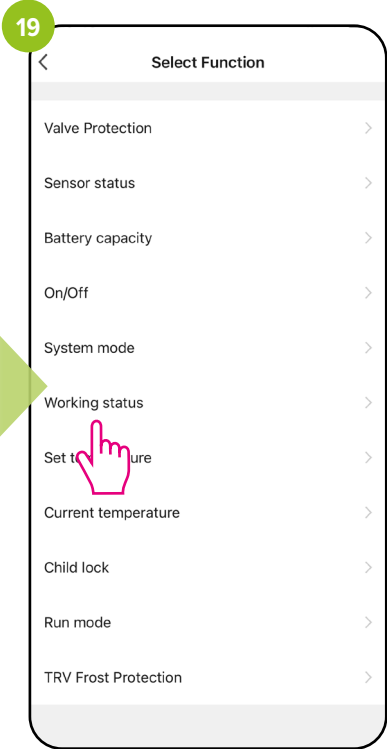

Select „Working Status”.

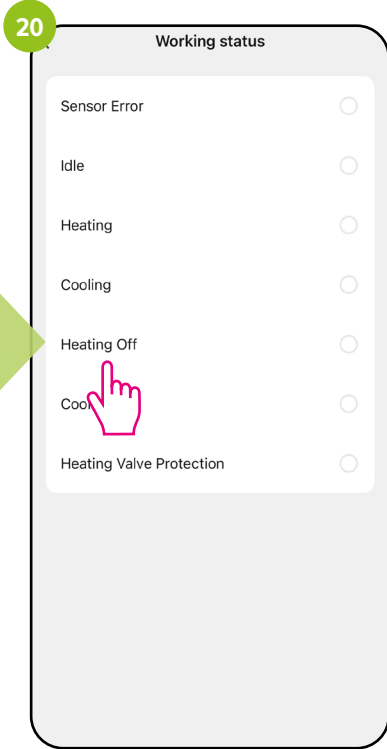

Select „Heating off”.

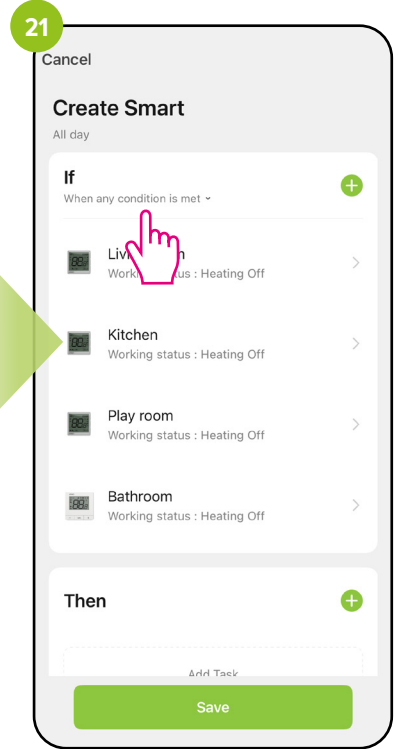

Click on the principle of conditions.

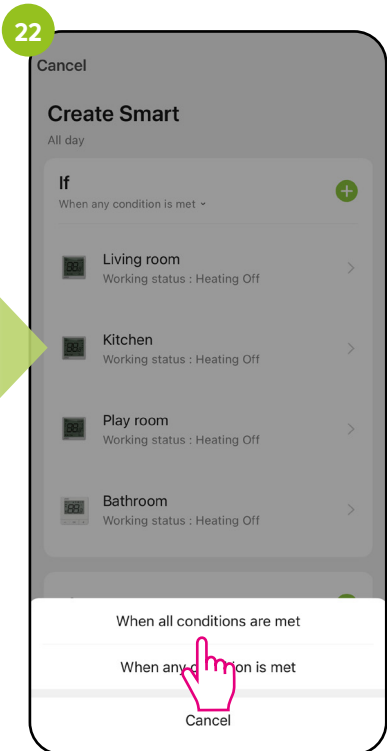

Select „When all conditions are met”.

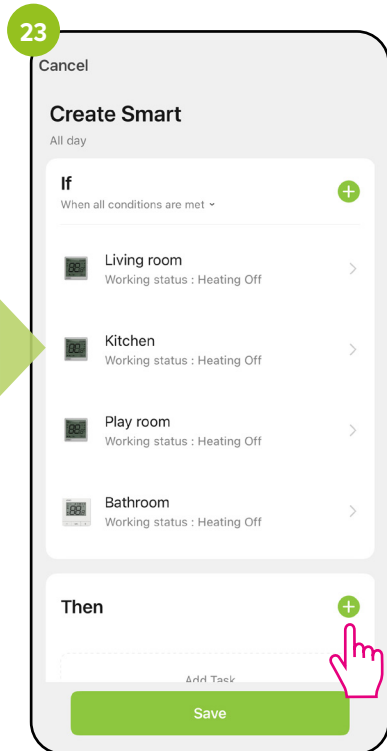

Add an action to perform.

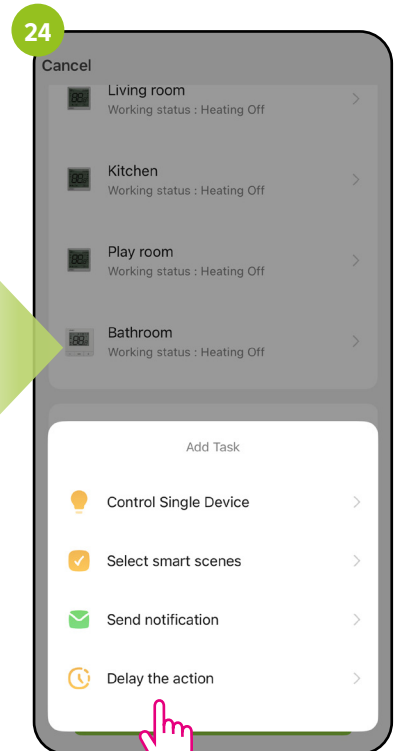

Select „ Delay the action”.

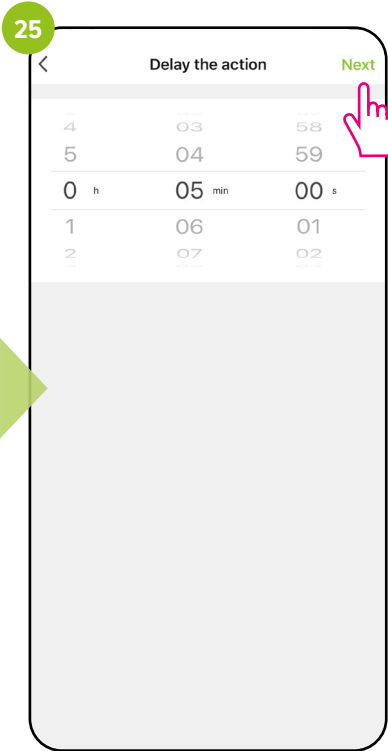

Set a delay time, and click „Next”.

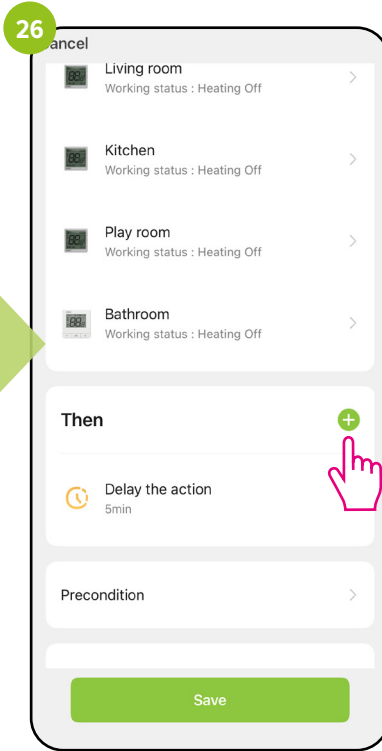

Add an action to perform.

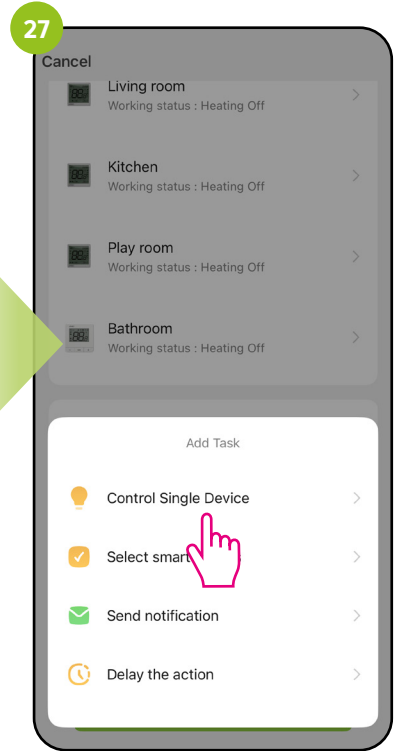

Select „Control Single Device”.

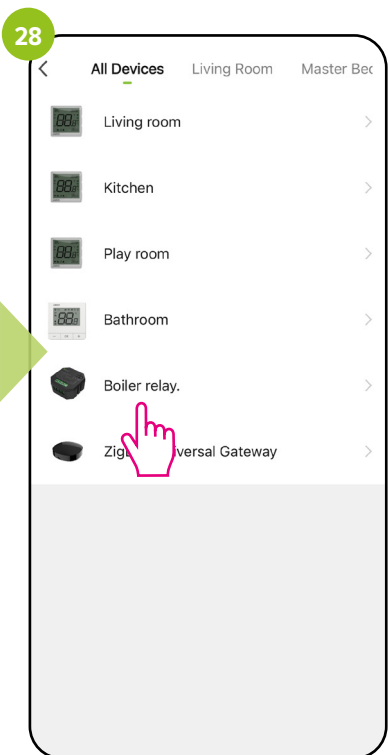

Select the relay to control the heat source.

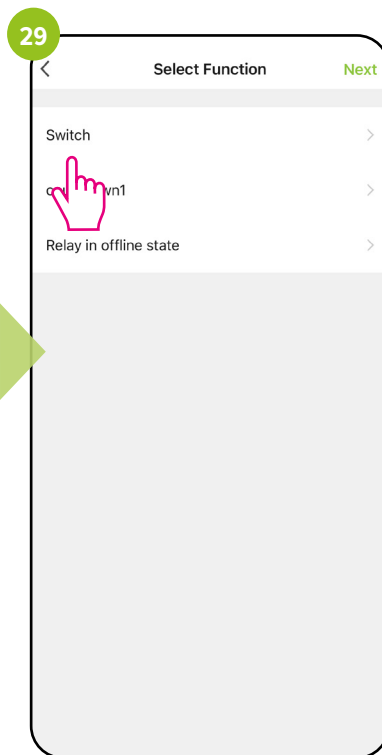

Select „Switch”.

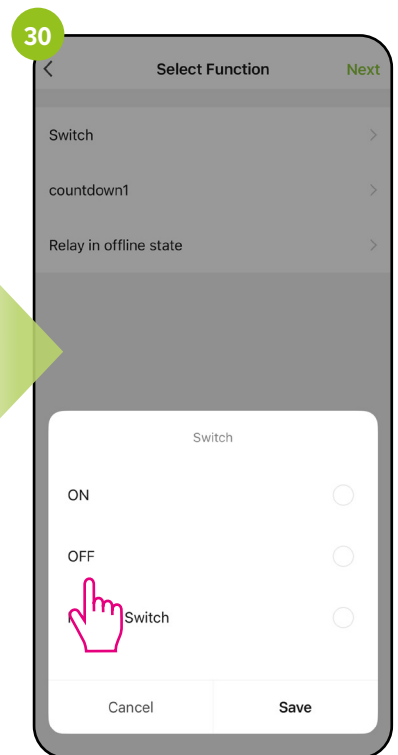

Select „OFF”.

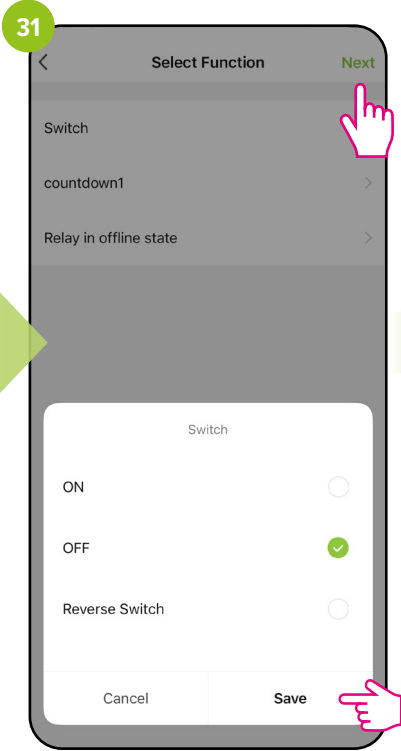

Click „Save”.

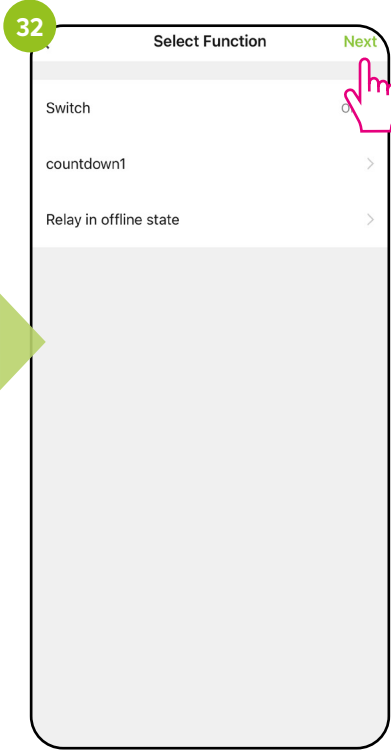

Add an action to perform.

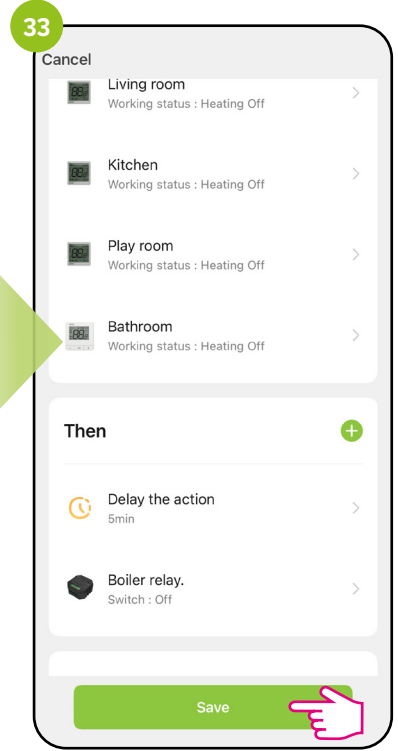

Save the automation.

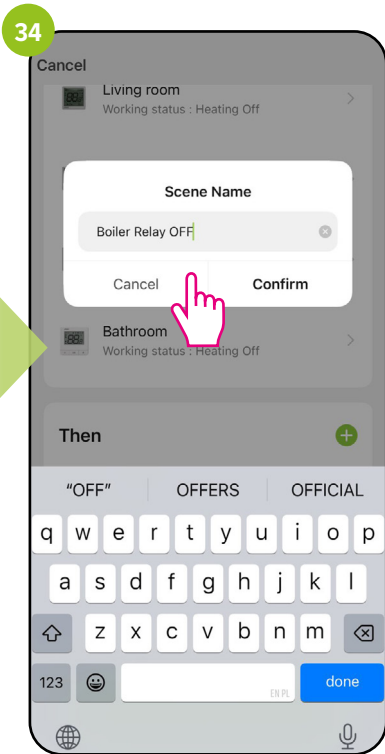

Name the scene, and confirm.

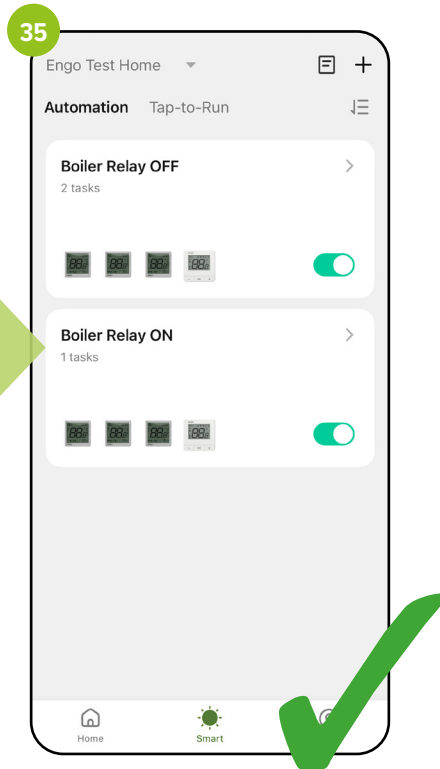

The heat source exemption rule has been created.

22.5 Create a group

Simultaneous control will be available once a new group has been created and the selected thermostats have been assigned to that group. A virtual master thermostat will then appear on the desktop, allowing all parameters in the grouped thermostats to be overwritten.

For example: If you set manual mode in the virtual thermostat, every thermostat in that group will switch to manual mode. See the following steps on how to group several thermostats.

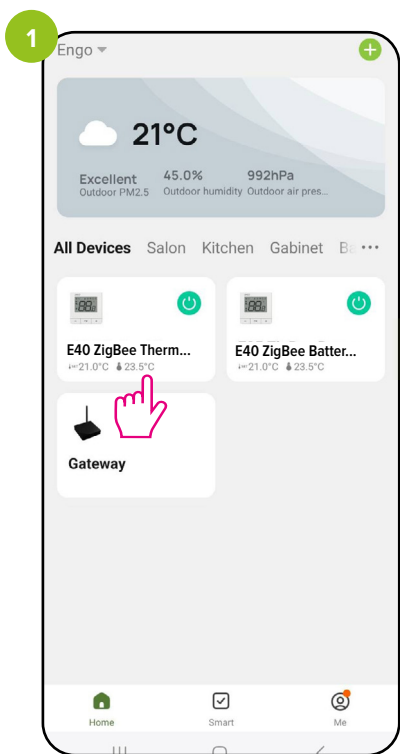

Enter the thermostat interface.

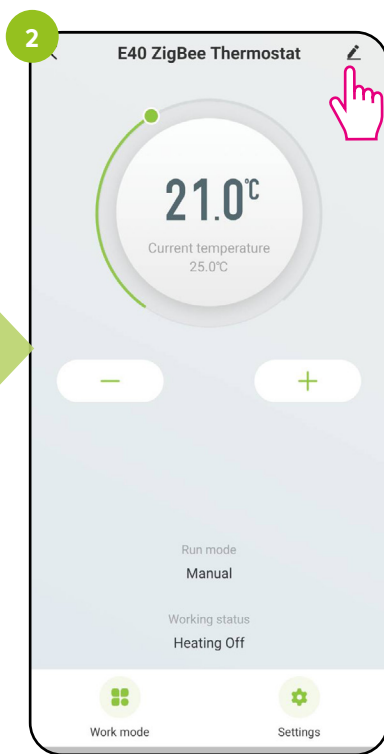

Click on the pencil icon in the upper corner.

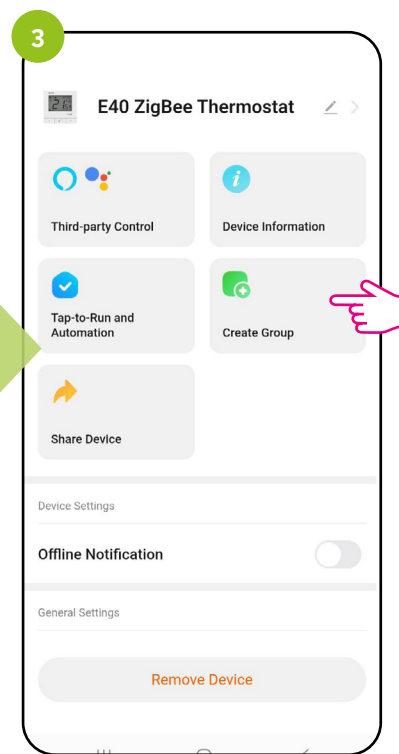

Select „Create group”.

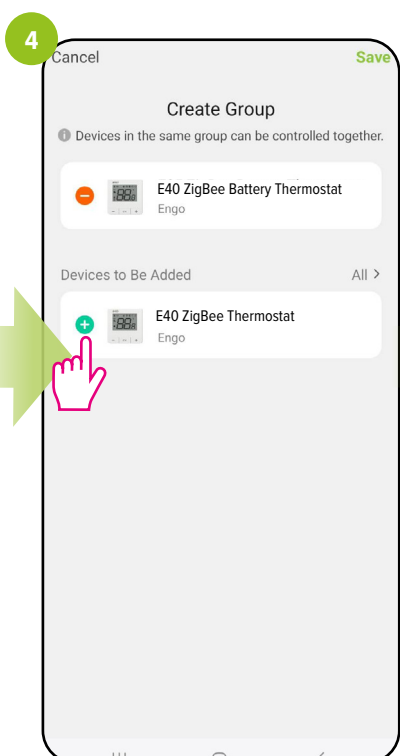

Select the devices you wish to assign to a group.

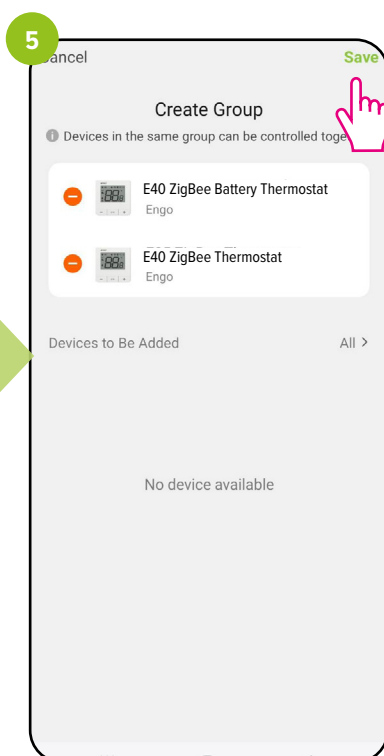

Click „Save”.

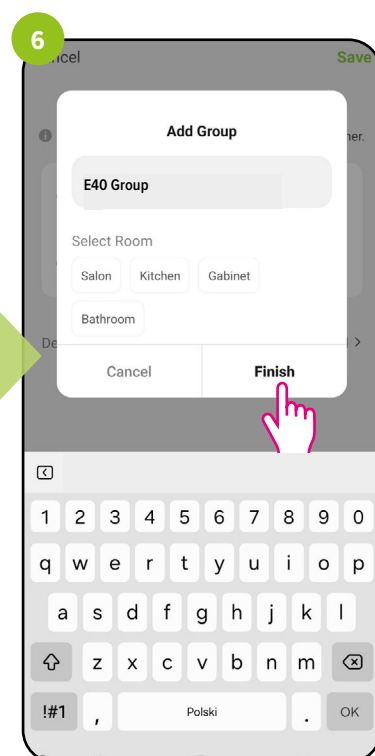

Name the group and click „Finish”.

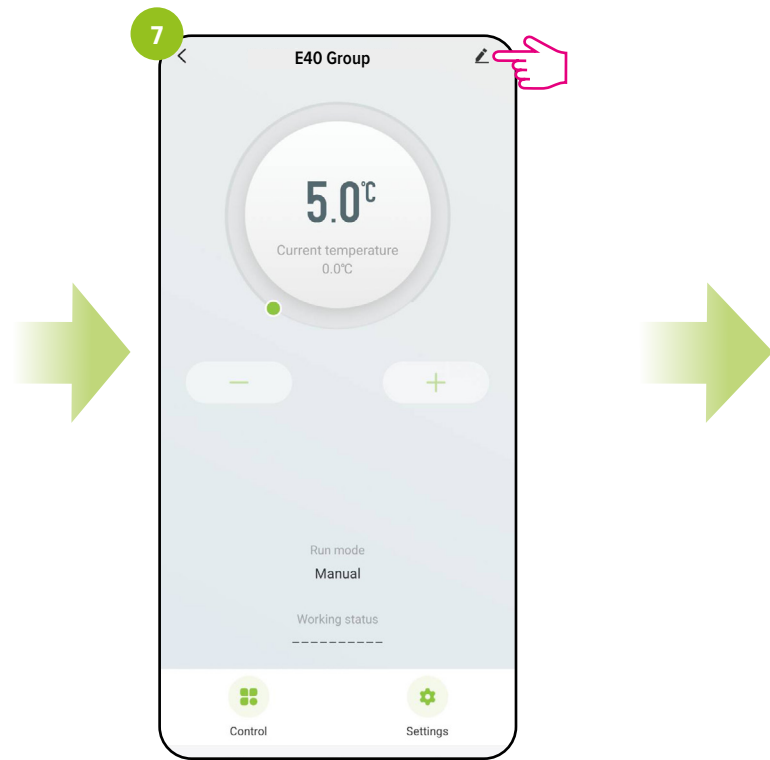

The main interface for group management interface, from where you can set the temperature or change operating modes / settings.

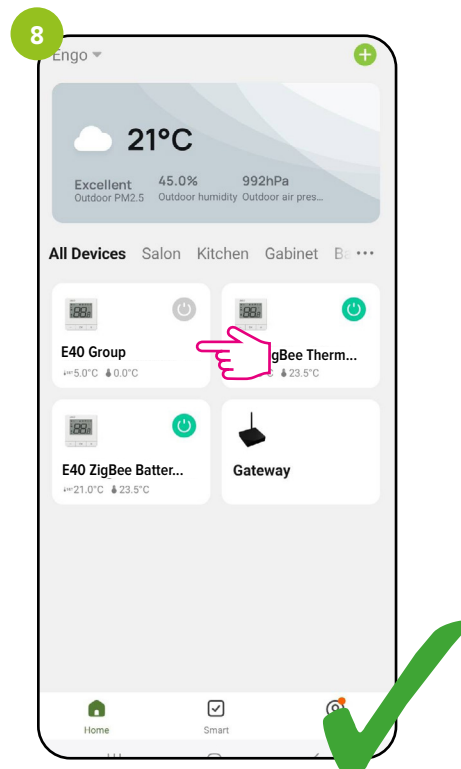

The group will automatically also appear on the main application screen.

22.6 FAQs and feedback

Find the answer to your problem in the FAQs and feedback by searching for a specific key word. If you have not found the answer, please contact technical support.

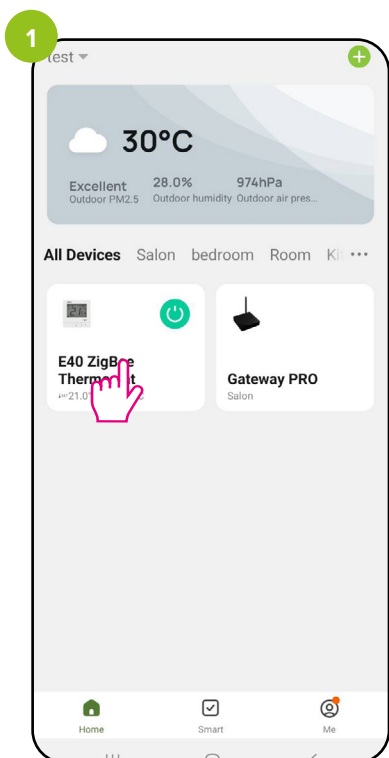

Enter the thermostat interface.

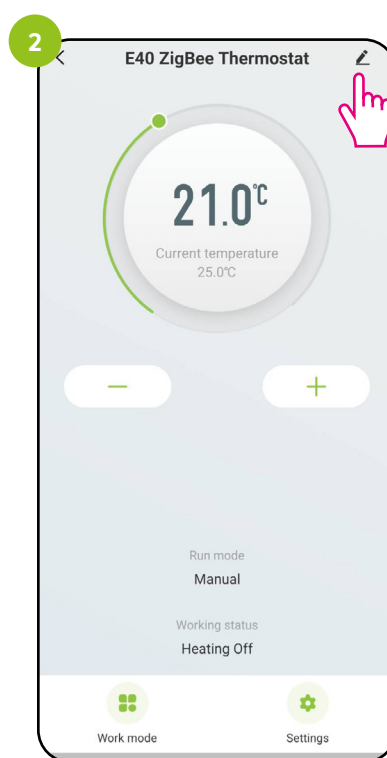

Click on the pencil icon in the upper corner.

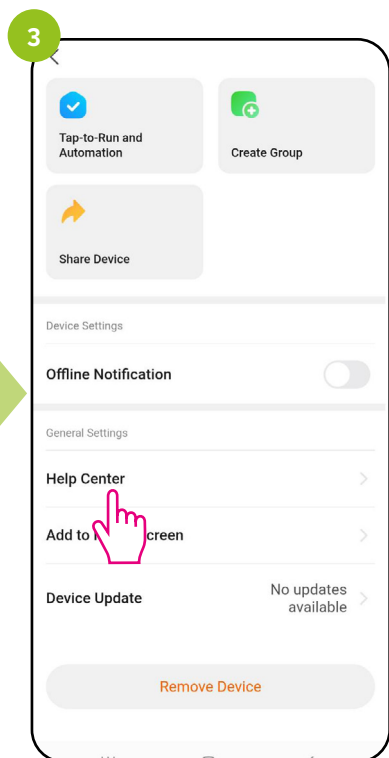

Select „Help Center”.

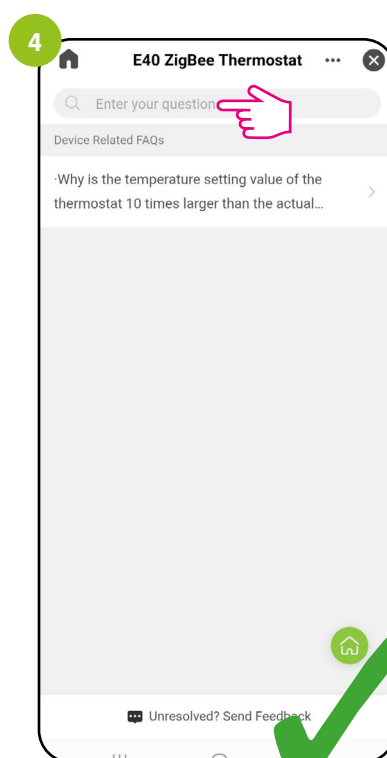

Type in your problem and the application will automatically start searching for possible answer.

22.7 Add an icon to the home screen (create a shortcut on the phone's desktop)

If you are tired of constantly opening the app to access the thermostat's settings, or if you want to set a new temperature - pin the thermostat to the main desktop of your smartphone. See steps below:

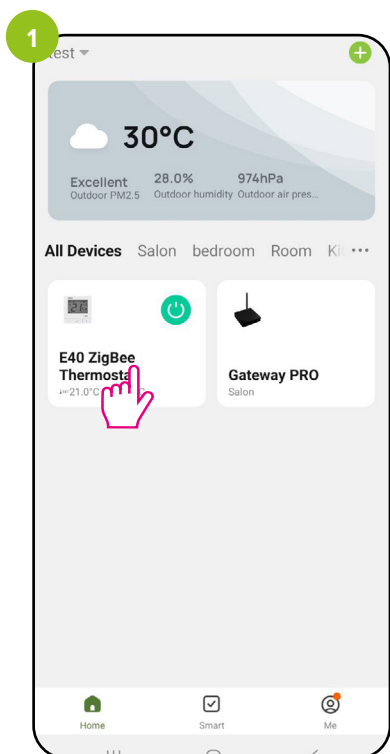

Enter the thermostat interface.

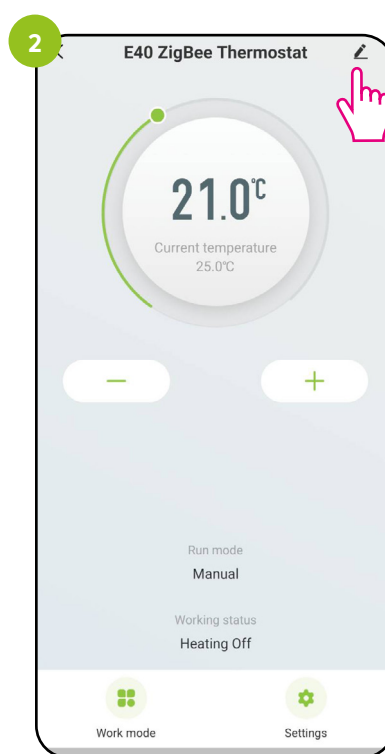

Click on the pencil icon in the upper corner.

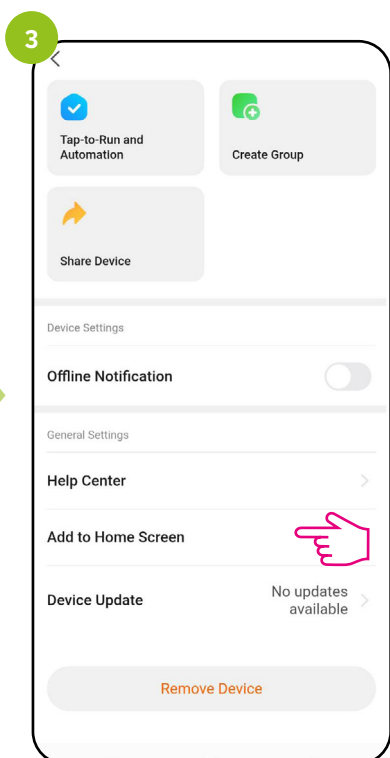

Select „Add to the home screen”.

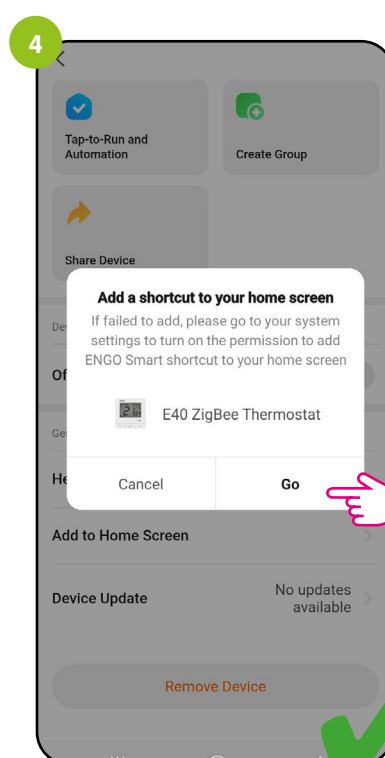

Confirm with „Go”. Afterwards, a shortcut to the thermostat will appear on the desktop of your phone.

22.8 Check available updates for a single device

Allows you to update the device software to the latest version. The update can be started manually or an automatic option can be selected.

22.8.1 Updating devices automatically

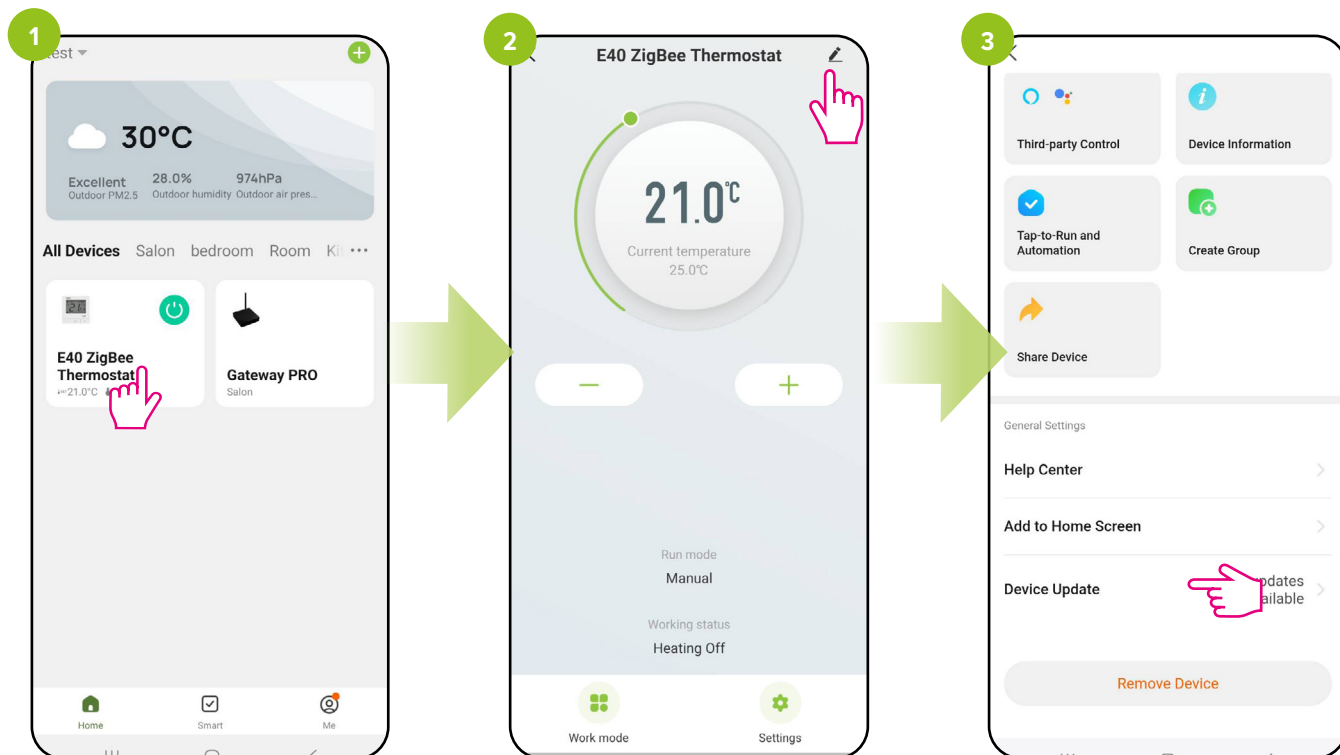

Enter the thermostat interface.

Click the pencil icon in the top right corner.

Select „Device Update“.

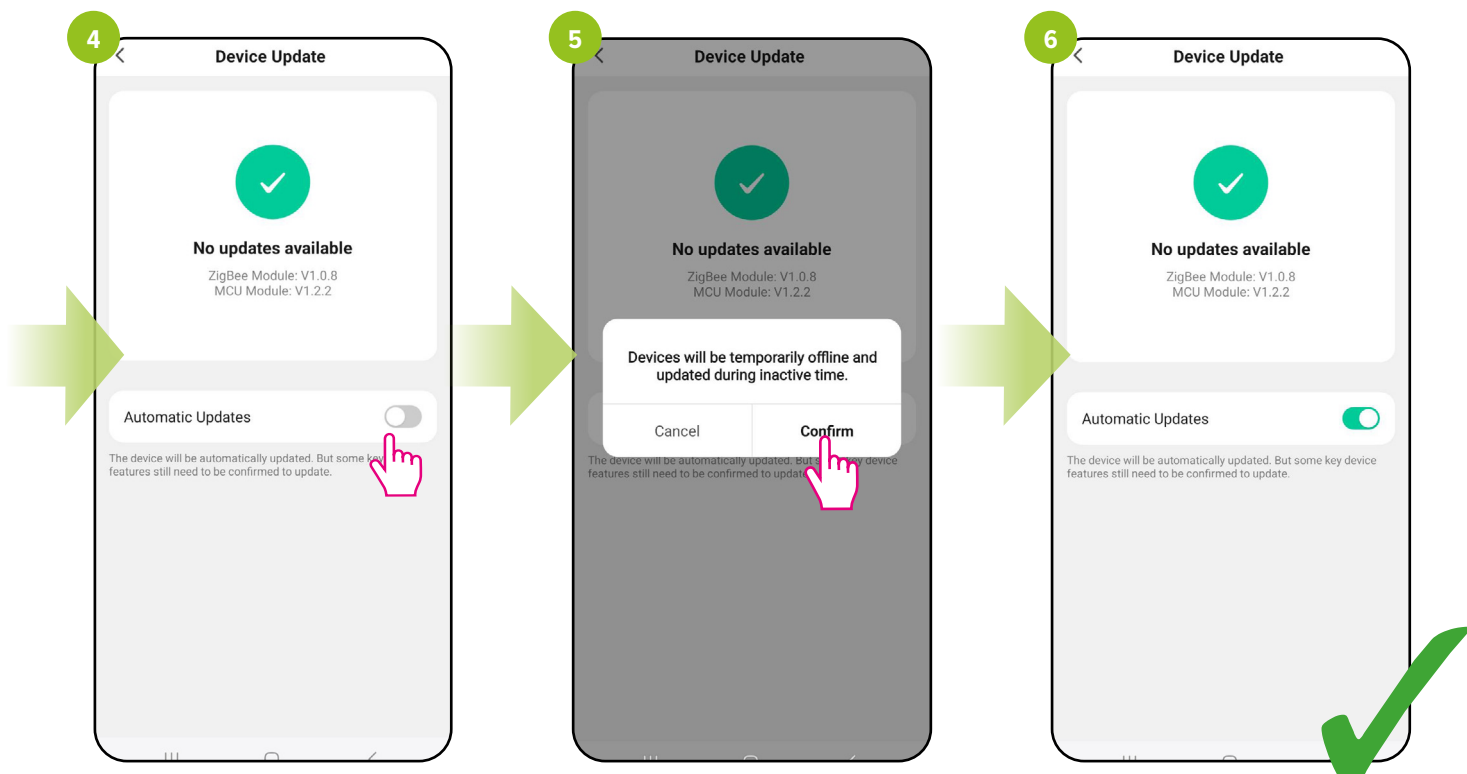

Check this option if you want the thermostat software to always update automatically.

Confirm.

From now on, whenever there is new software, the thermostat will initiate the update.

22.8.2 Updating devices manually

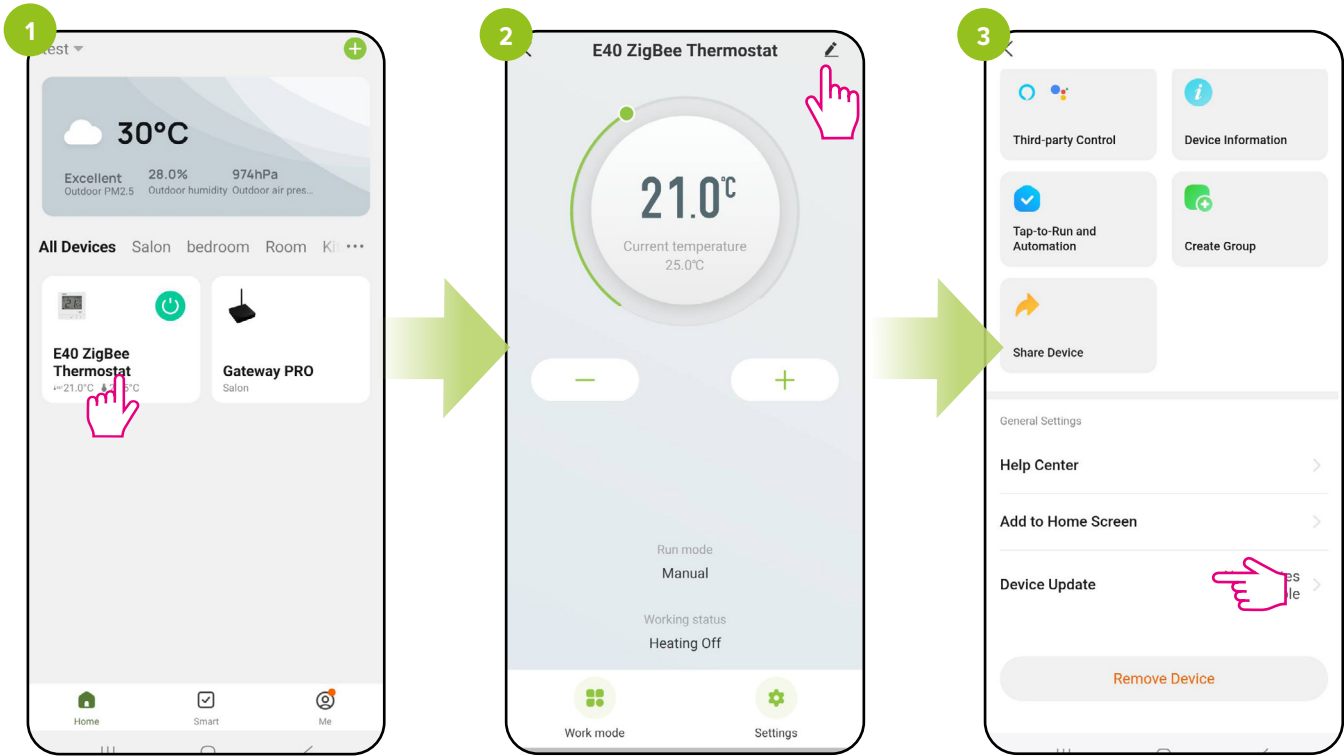

Enter the thermostat interface.

Click the pencil icon in the top right corner.

Select „Device Update“.

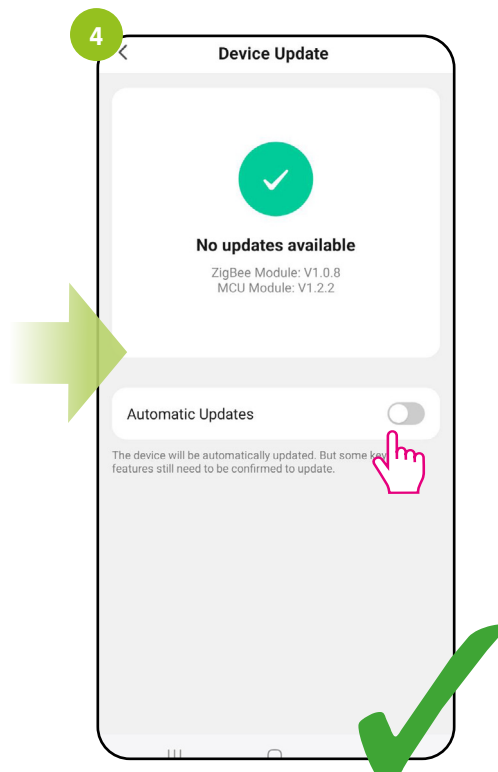

Leave this option unchecked if you want the thermostat software to update manually.

22.8.3 Checking whether updates are available for installed devices

If you have selected a manual update trigger in the device update settings, you can check in one place whether there are updates available for the installed devices. To do this, follow the steps below.

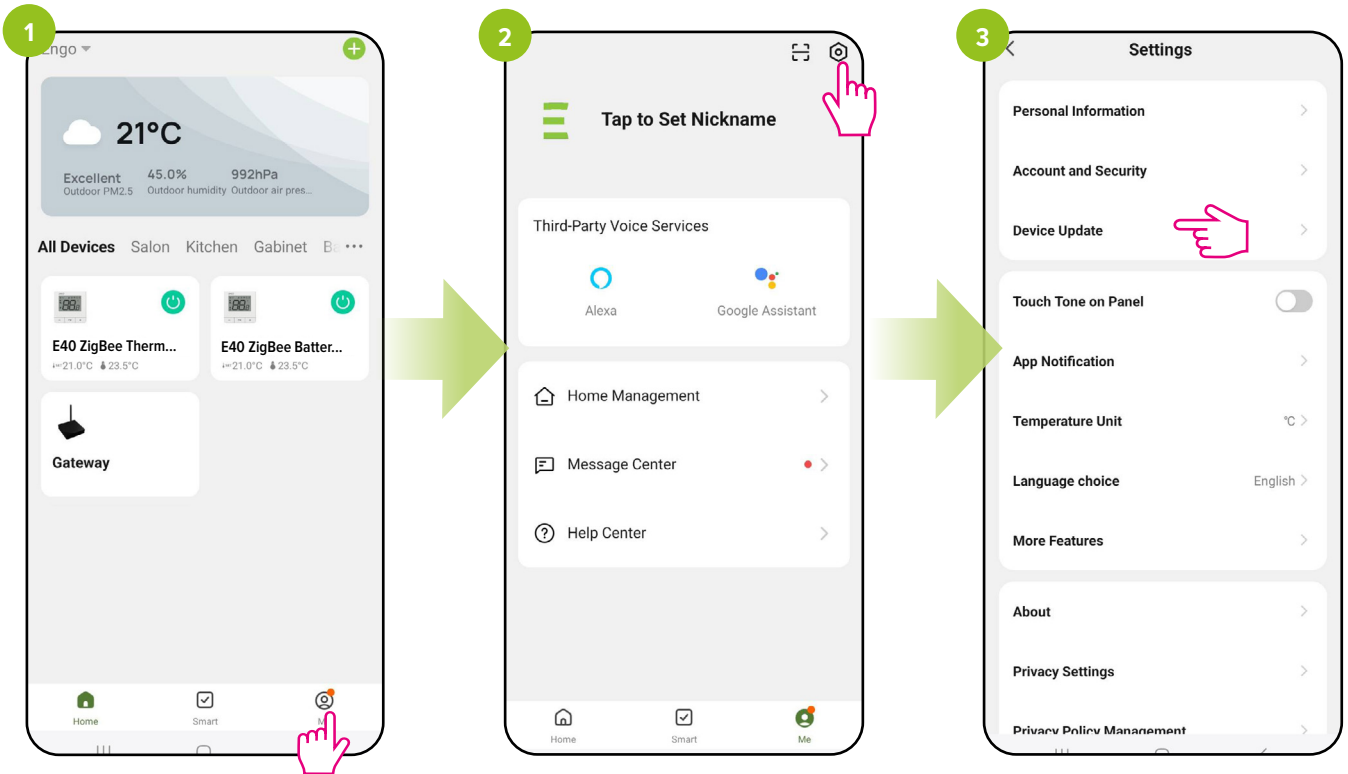

Click „Me”.

Click the hexagon icon in the top right corner (system settings).

Select „Device Update”.

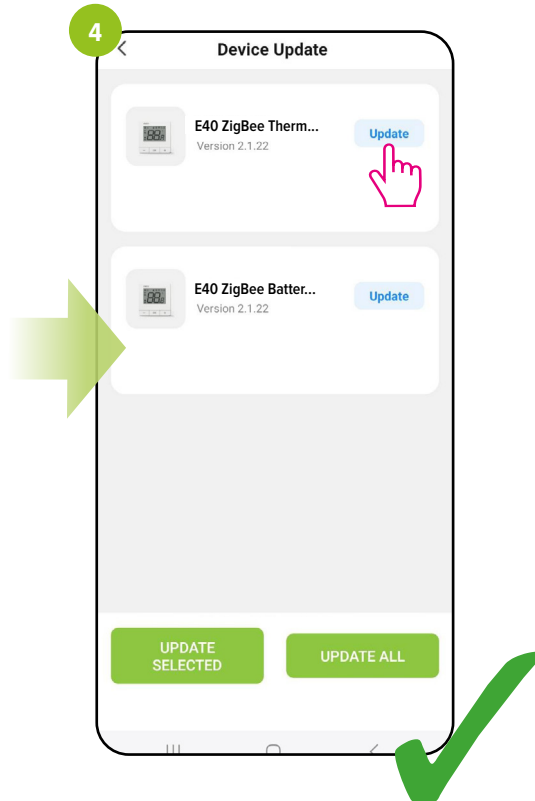

Available updates for installed devices will be visible. Clicking „Update” will trigger an update for the selected device.

23. Sharing facilities/home with other users

The ENGO Smart app gives you the possibility to share your home with other users. You can also assign a user the role of administrator/standard user. To do this, follow the steps below.

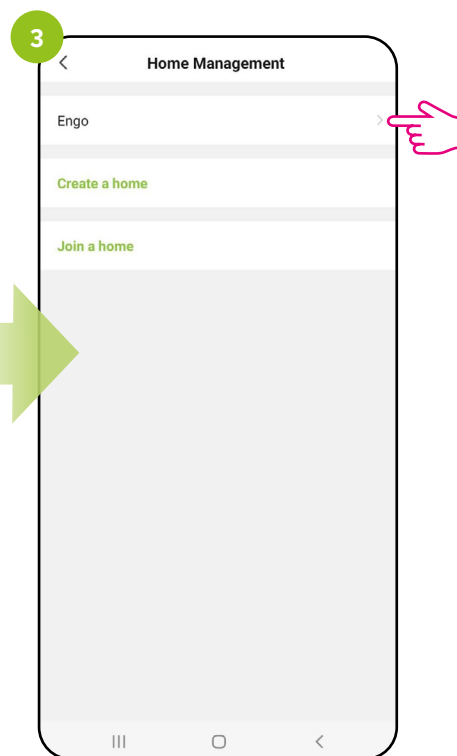
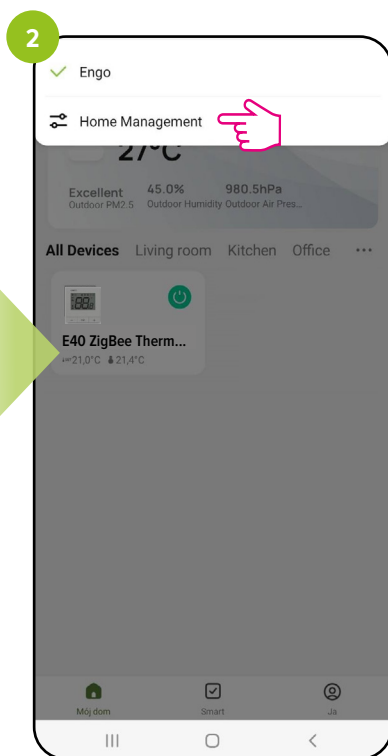
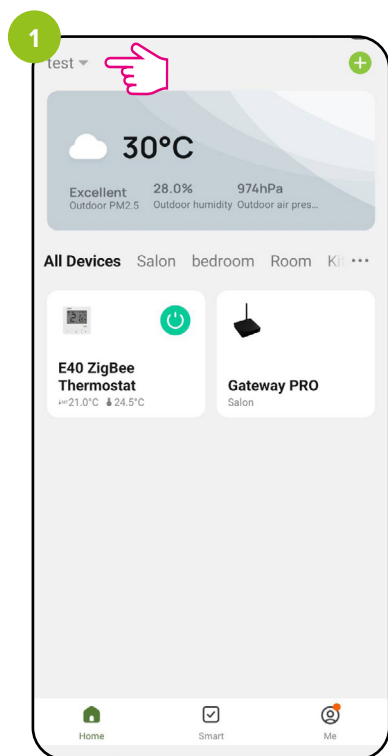

Enter „Home Management”.

Select your home.

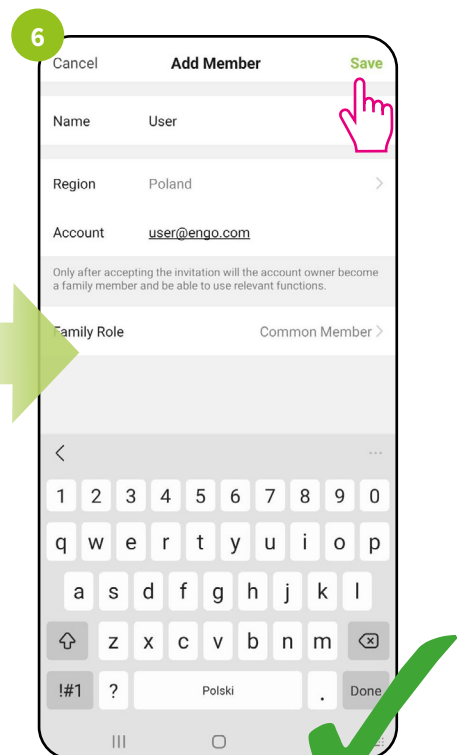
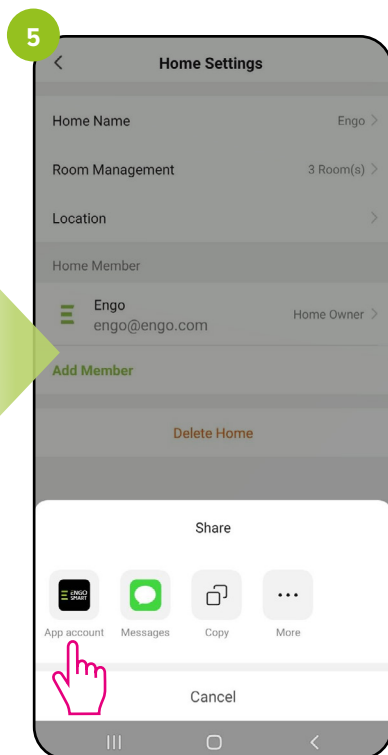
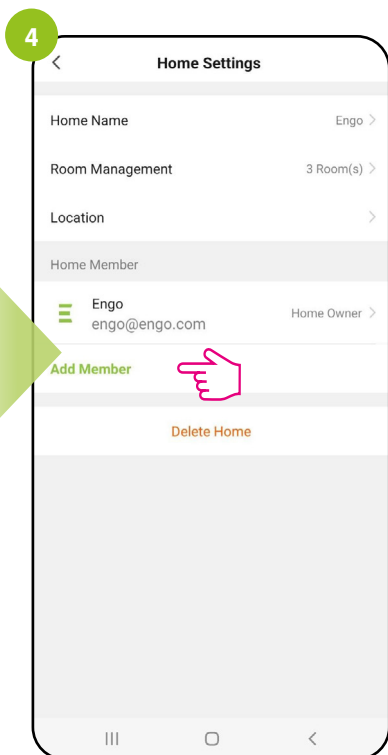

Add Member.

Choose an invitation method.

Enter the house member details and click „Save”.

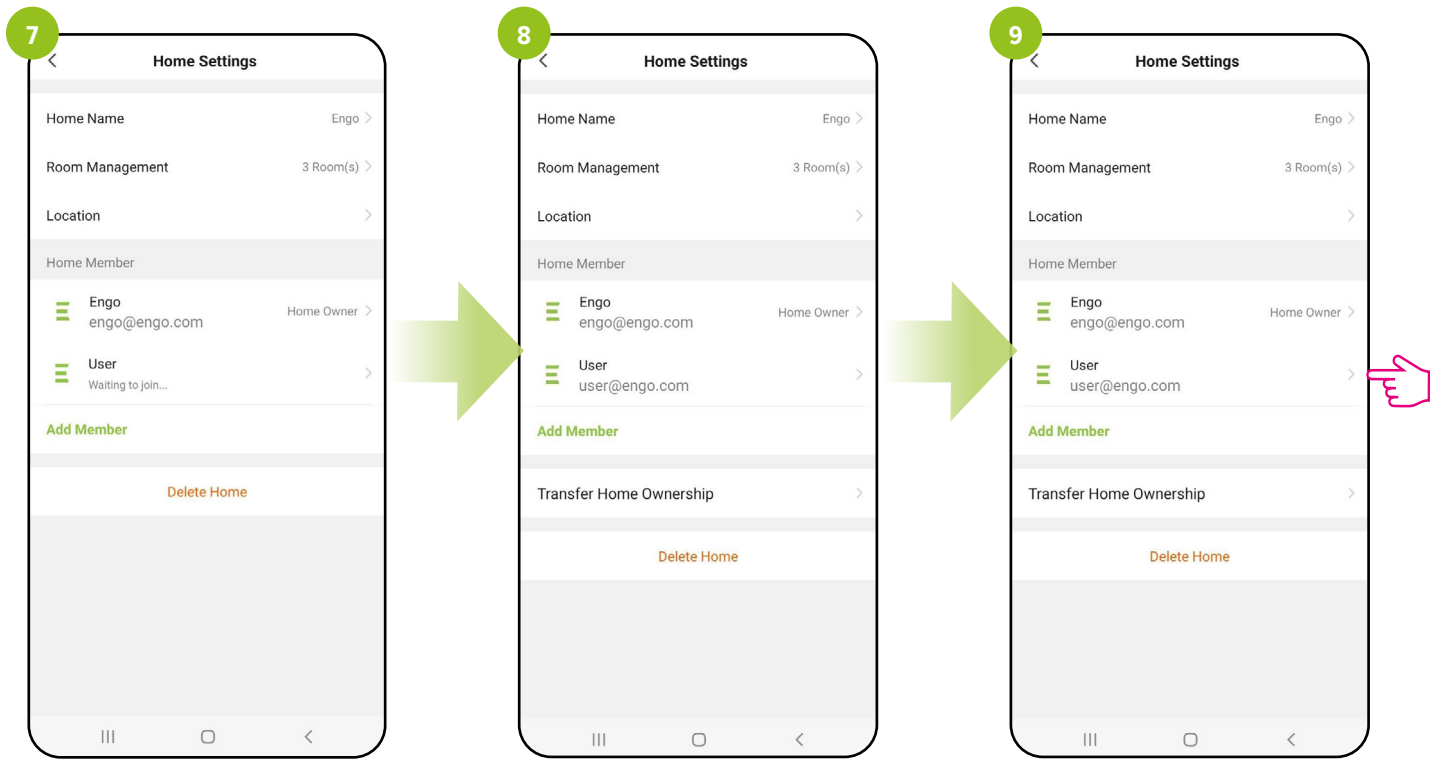

The invited user must confirm their desire to join home.

When the user accepts the invitation, will be visible in the list of home members.

To go to edit click on the username.

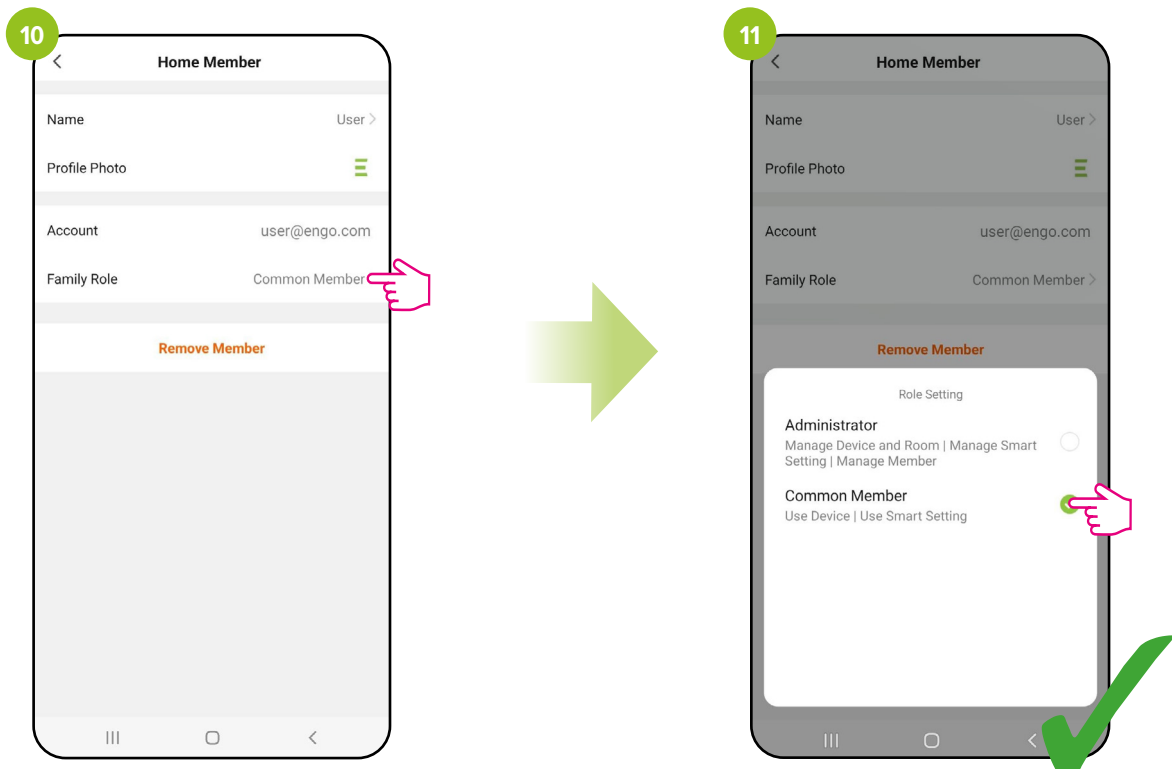

We can edit the name of the user and permissions by clicking „Family Role”.

A member of the home can be given administrator permission or standard member.

24. Alarms / Push notifications / Emergency states

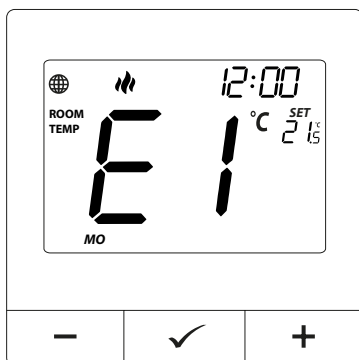

E1 - Short circuit in the internal temperature sensor circuit

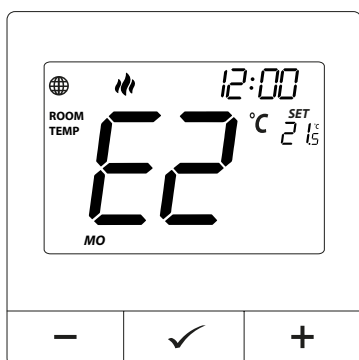

E2 - Break in the temperature sensor circuit

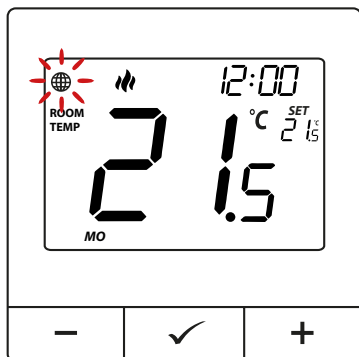

(GLOBUS) is flashing - Connection to the ZigBee gateway is lost

- Check if the gateway, repeater (in other words ZigBee device, powered by 230V to extend the network range) is connected to the power supply

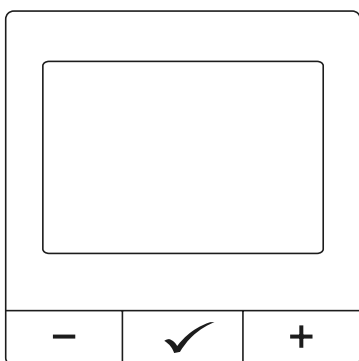

The thermostat has the display turned off

- Check that the thermostat is not switched off from within the application. You can also check by clicking on any key - then the message „OFF” will appear on the regulator screen

- Check that the regulator batteries are not completely discharged, if so, replace the batteries

Alerts.
Follow the steps below to access the notifications:

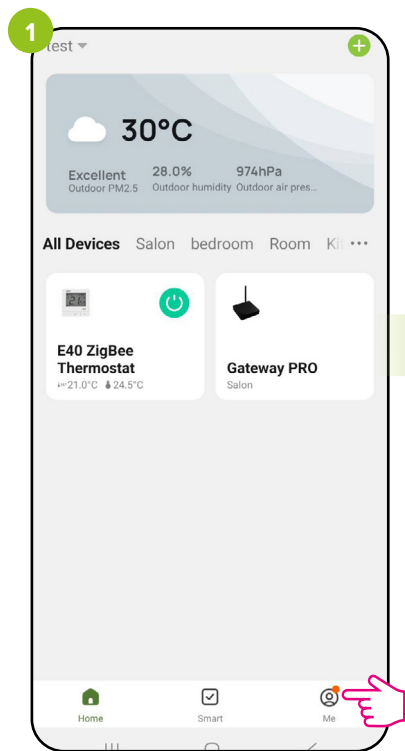

Enter „Me” menu.

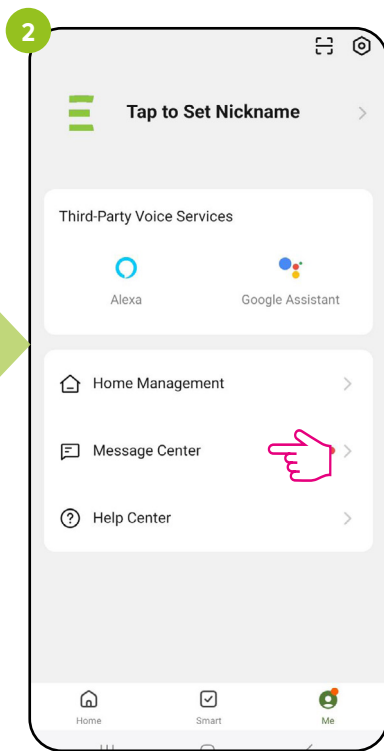

Select the message center.

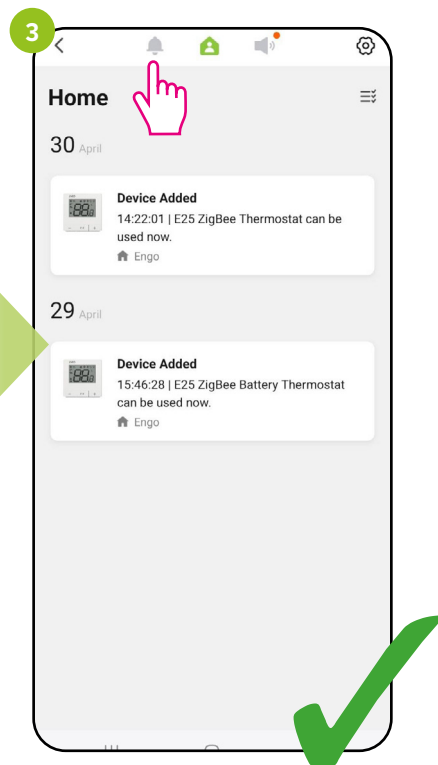

Jump sequentially between the tabs:
Alarm, Devices and Notifications in order to find
a message or notification concerning regulator.

25. Removing the device from the application

To remove the E40 thermostat from your account, follow the steps below:

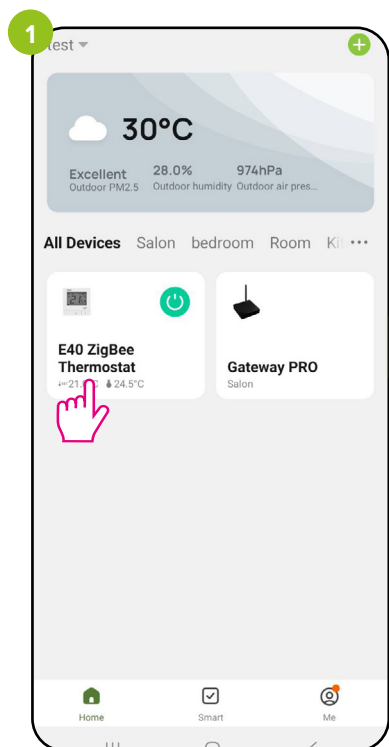

Enter the thermostat interface.

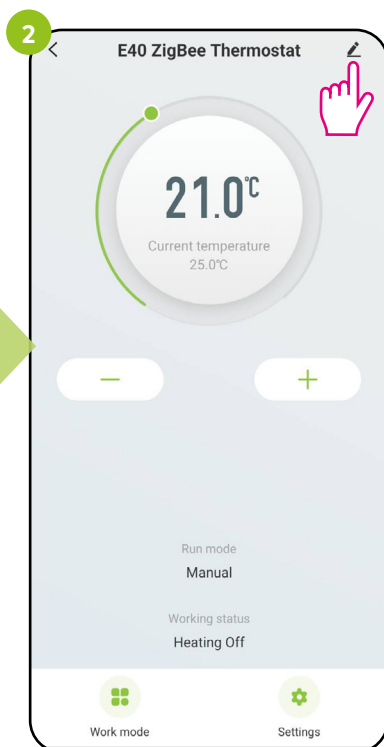

Click the pencil icon in the top right corner.

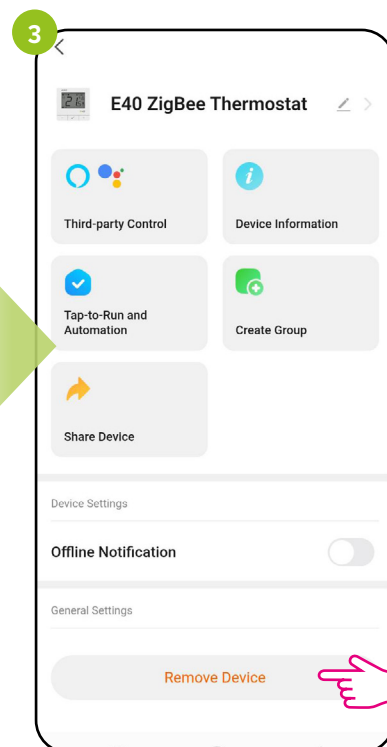

Select „Remove Device”.

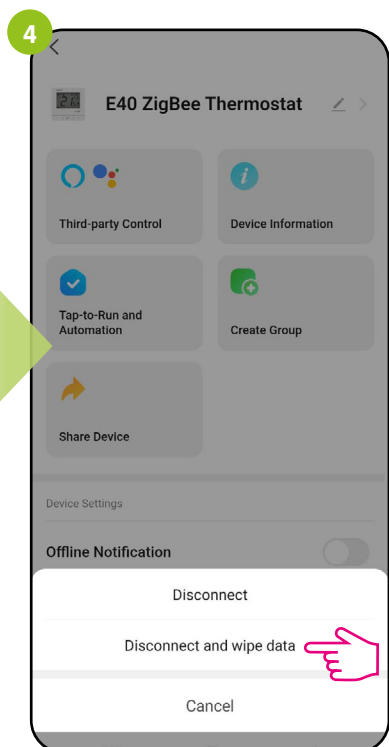

Choose how to remove the device from the application.

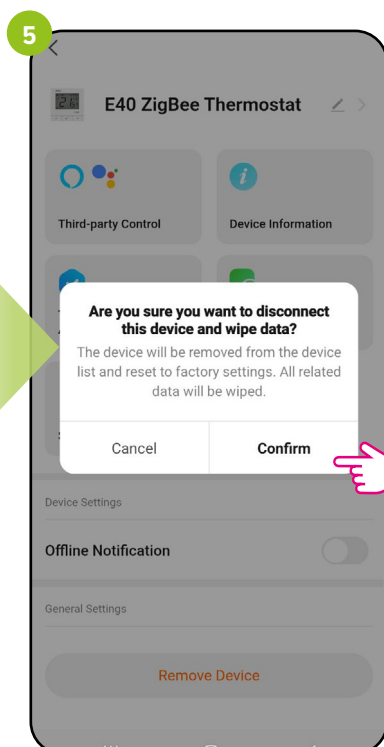

Then confirm.

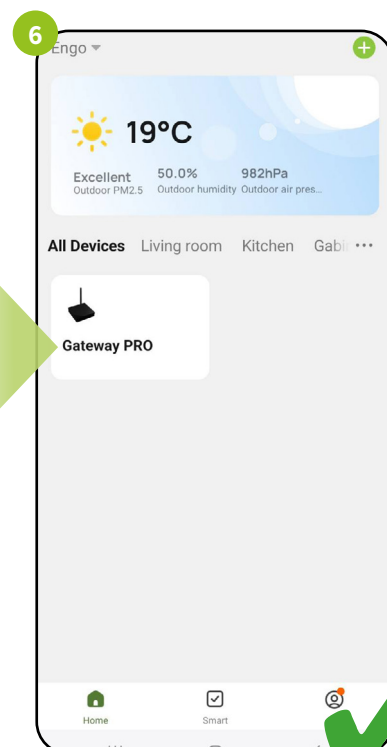

The regulator has been removed from the application.

ATTENTION!!!
Disconnect - the device will be removed from the application - all associated „Tap-To-Run” scenes and automated scenarios will be unavailable. The next time you connect to the app, the device will add itself with the previous settings, but the „Tap-To-Run” rules will have to be created from scratch.
Disconnect and clear data - the device will be removed from the app and will be reset to factory settings.

26. Factory reset

To RESET Thermostat to factory settings, hold down the – and + buttons until the „FA” message appears. Then release the keys. Then use the - or + button to change “NO” to „YES” and confirm with ✓ button. Thermostat will restart, will restore the default factory settings and display the main screen. If the thermostat has been added to an internet gateway and ZigBee network, it will be removed from the gateway and will need to be added / paired again.

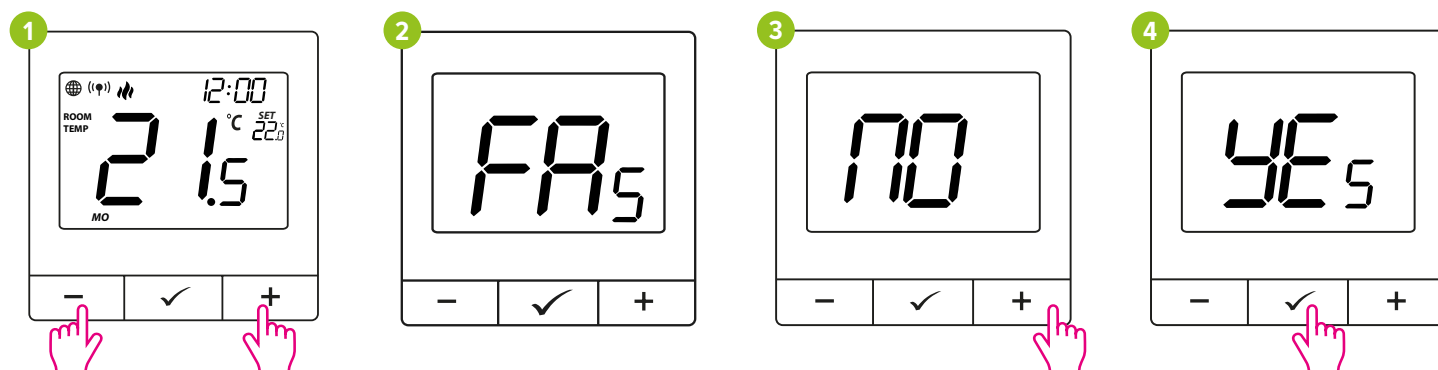

27. Cleaning and maintenance

The E40 regulator requires no special maintenance. Do not use brushes, scrubbers or other tools that may scratch the surface of the regulator for cleaning and maintenance, and do not use abrasive, foaming agents or aggressive substances containing acids, chlorine or its compounds, solvents or bleaching agents, as this may damage the regulator. Always clean the display and buttons with a damp soft cloth. Plastic surfaces can also be cleaned with colourless, mild cleaning agents. The cleaning agent should not be sprayed directly onto the device. After washing the surface, it can be gently polished with a soft, dry cloth. There are no user serviceable/replaceable parts inside the appliance. Service or repair can only be carried out by an authorised ENGO Controls service centre.

28. Technical data

Power supply	230V AC 50Hz
Temperature control range	5.0°C to 45.0°C
Temperature display accuracy	0.5°C
Control algorithm	TPI or Hysteresis ($\pm 0.2^{\circ}\text{C}$ to $\pm 2.0^{\circ}\text{C}$)
Communication	ZigBee 3.0 2.4GHz Radio 868MHz
Output control	COM / NO (Voltage-free)
Dimensions	80 x 80 x 23 mm

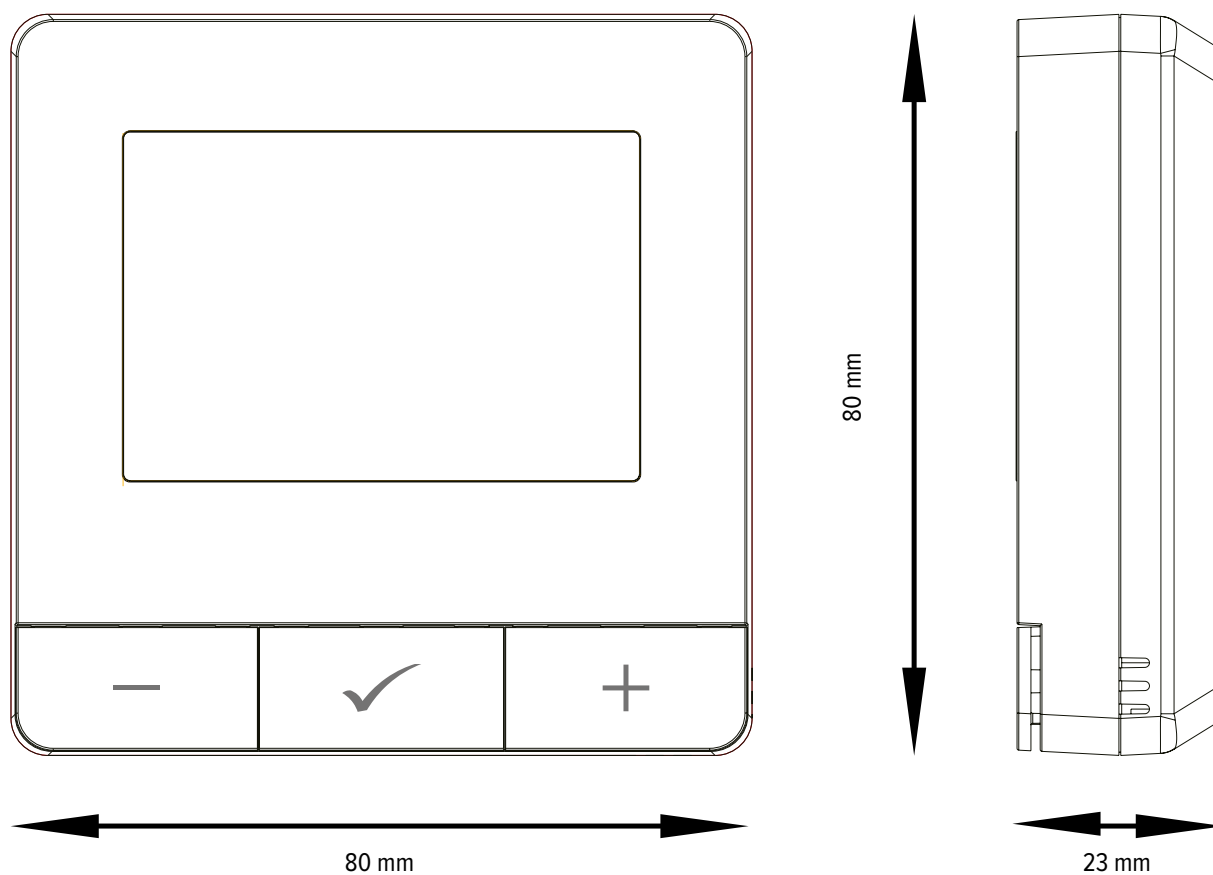

29. Warranty

ENGO CONTROLS warrants this product to be free from any defects in material or workmanship and to perform in accordance with specifications for a period of five years from the date of installation. ENGO CONTROLS reserves the sole responsibility for breach of this warranty by repair or replacement of a defective product. This product has been equipped with software in accordance with the distributor's designation at the time of sale. The manufacturer/distributor provides a warranty covering all features and specifications of the product in accordance with this designation. The distributor's warranty does not cover the correct operation of functions and features available as a result of product software updates. The full terms and conditions of the warranty are available at www.engocontrols.com.

Client name:.....
Customer address:
Postal code:
Telephone number:
Email:

Company name:
Telephone number:
Email:
Installation Date:
Name of installer:
Installer's signature:



ENGO

Ver. 1.0
Release date: IX 2025
Soft:
ZigBee: v1.0.8
MCU: v0.1.2



Producer:
Engo Controls sp. z o.o. sp. k.
4Rolna 4St.
43-262 Kobielice
Poland

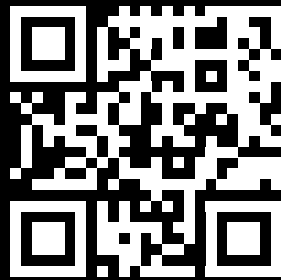

engocontrols.com